

THE FIRST PERSONAL COMPUTER MAGAZINE  
PRODUCED ENTIRELY WITH PERSONAL COMPUTERS!



YOUR GUIDE TO COMMODORE & AMIGA COMPUTING!

# INFO

# THE

# GLOBE DATA

**DESKTOP PUBLISHING FINALLY COMES TO COMMODORE & AMIGA USERS.**

**N**ew products give Commodore and Amiga users long-awaited full-featured desk-top publishing capabilities at a fraction of the cost of equivalent Mac and IBM-based systems!



**I**n its January/February Issue, INFO begins the first of a series of informative articles designed to introduce readers to the exciting (and sometimes overwhelming) world of Desktop Publishing. In the first installment, a wide range of entry-level tools are examined and reviewed. Part II will deal with professional level products and Laser Printers.

Desktop Publishing is the term coined by Aldus in 1985. (Inc) Corp. INFO had fit

**DISK VIRUS RAGES THRU UNSUSPECTING AMIGA USER COMMUNITY!**

**INFO FIRST TO PRINT DETAILS AND CURE!**

**STORY & PHOTOS ON PAGE 22**



**A**s incredible as it seems, a "terrorist"-style software vandal has created a major panic in Amiga circles with a self-replicating virus which passes from disk to disk, and which may now be spread across the globe!

Fortunately, Commodore trouble shooters have already created and begun distributing an effective "anti-virus" which easily fixes "infected" disks. Read all about it, and learn how you can be protected.

**TRADE SHOW REPORTS:**

# COMDEX Fall '87

**I**INFO reports from COMDEX, AmiExpo, & The Commodore Show. Most people go to Disneyland and Las Vegas to frolic and get away from it all: here at INFO, travel to these towering testaments to tourism is serious business- a dirty job (but somebody has to do it). So, Mickey-Moused, foot-sore, and gambled-out, our intrepid staff bring you the latest and greatest straight from the big shows.

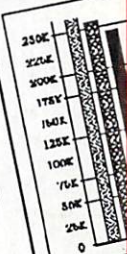

NOW INCLUDES:

Midnite Software Gazette



# DIGI VIEW

## DELIVERS ULTIMATE GRAPHICS POWER

Bring the world into your Amiga with Digi-View, the 4096 color video digitizer. In seconds you can capture any photograph or object your video camera can see in full color and with clarity never before available on a home computer. Digi-View's advanced features include:

- Dithering routines give up to 100,000 apparent colors on screen
- NewTek's exclusive Enhanced Hold-and-Modify mode allows for exceptionally detailed images
- Digitize images in any number of colors from 2 to 4096
- Print, animate, transmit, store, or manipulate images with available IFF compatible programs
- Digitize in all Amiga resolution modes (320x200, 320x400, 640x200, 640x400)

**"Digi-View sets new standards for graphics hardware"-InfoWorld**

Digi-View is available now at your local Amiga dealer or call:  
1-800-843-8934

**ONLY \$199.95**

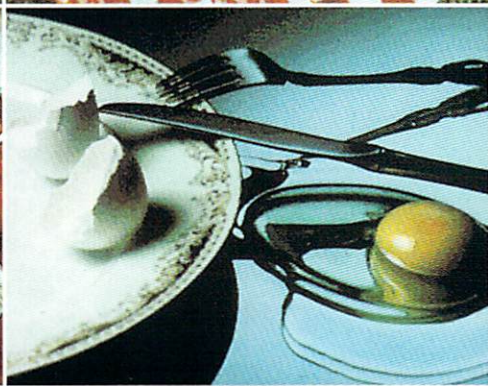

**NewTek**  
INCORPORATED



The adventure begins.

# Death Castle

“Simply astounding. Perhaps the best arcade game on any minicomputer ever.”  
Computer Gaming World

“The action is fast and furious, the scripting sublime.”  
Macworld

“The best and most addicting game to come along in a very long time.”  
MacUser

Now available for Amiga, Atari ST, Commodore 64, IBM PC and compatibles.

Three-Sixty Pacific, Inc.  
2105 So. Bascom  
Campbell, Calif. 95008  
(408) 879-9144



# CONTENTS #18

Page 50



## Features

- 22 VIRUS!
- 50 POWERFUL CARTRIDGES
- SHOW REPORTS:
- 76 ■ The Commodore Show
- 78 ■ AmiExpo
- 81 ■ COMDEX
- DESKTOP PUBLISHING
- 70 ■ Amiga DP
- 49 ■ GeoPublish
- 74 ■ DP Previews
- 84 EMULATING THE 64



Page 22

## Departments

- 10 16-BIT GALLERY
- 16 8-BIT GALLERY
- 26 READER MAIL
- 24 MAGAZINE INDEX
- 27 NEWS/VIEWS/RUMORS
- 31 NEW PRODUCTS
- 40 MIDNITE GAZETTE
- 21 INFO UPDATE
- 53 REAL WORLD
- 35 BEST OF PUBLIC DOMAIN
- 102 ADVERTISER INDEX
- 96 BACK ISSUES
- 102 UNCLASSIFIEDS
- 42 USER-GROUP UPDATE
- 44 GEOS UPDATE
- 73 THE MAKING OF INFO

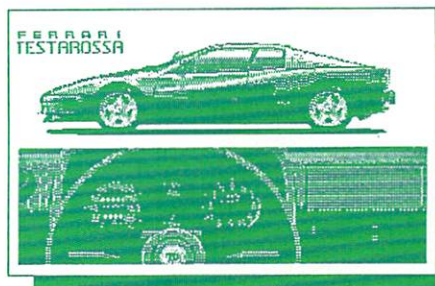

Page 10

Page 64



## Reviews

- C64**
- 54 PRINTMASTER PLUS
- 56 TOY SHOP
- C128**
- 58 SUPERPAK II
- AMIGA**
- 61 TRUE BASIC
- 64 WORDPROCESSORS

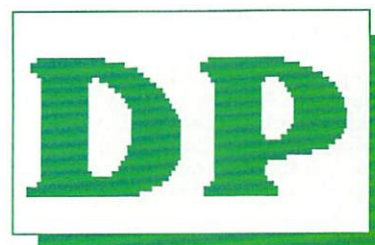

Page 70



IS:

**Benn Dunnington**

Publisher, Editor, Founder

**Mark R. Brown**

Senior Editor, Tech Editor

**Tom Malcom**

Assistant Editor, Data Manager

**Megan Ward**

Art and Production Manager

**ASSOCIATE EDITOR:**

Jim Oldfield, Jr.

**CONTRIBUTING EDITORS:**

Don Romero  
Warren Block  
Karl T. Thurber, Jr.

**Advertising Sales**

Carol Brown  
(319) 338-3620

**READER MAIL:**

INFO Reader Mail  
123 N. Linn St.-Ste 2A  
Iowa City, IA 52240

COPYRIGHT © 1987 BY  
INFO PUBLICATIONS, INC.  
ALL RIGHTS RESERVED

INFO is an independent journal not connected with Commodore Business Machines. INFO is published bi-monthly by INFO Publications, Inc., 123 N. Linn St. Ste. 2A, Iowa City, IA 52240. Subscription rate is \$19.75 (U.S. funds), one year. Application for Second-Class Postage pending at Iowa City, IA 52240. Entire contents copyright 1987 by INFO Publications, Inc. No part of this publication may be printed or otherwise reproduced without written permission from the publisher. POSTMASTER: send address changes to INFO Subs. 123 N. Linn St. Ste. 2A, Iowa City, IA 52240. National and World distribution by Select Magazines, Inc. NY NY. INFO makes every effort to assure accuracy of articles, stories, and reviews published in this magazine. INFO assumes no responsibility for damages due to errors or omissions.

Products used to produce this issue of INFO include:



Superbase

Kodacolor VR-G

CITY DESK



PAPEROLIP™

VIZAWRITE  
PERSONAL WORD PROCESSOR

DIGIVIEW

Sculpt 3-D™

DIGI  
PAINT



fonts by

EARTHBOUND  
SOFTWARE



Skyles

QUICKSILVER 128™

SONY  
MONITORS



GRABBIT

REDMOND Cables

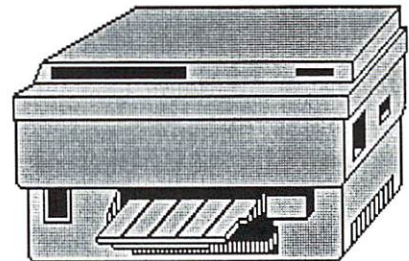

HP LaserJet Plus

DEAR GERRY

My Dad just got this neat computer. It's called an Amiga. Not Ameba. That's biology. This is computer science. Or, at least, that's what my Dad thinks he is. The naked truth, Gerry, is that this computer is a piece of cake. A moron could use it. Anyway, my Dad also bought this super little program called PageSetter. It's what I'm using right now to write to you. From now on expect great things from THIS budding author. Anyway, I gotta go now. I was going to tell you about my new school and how crummy it is. But I'll save that for next time. Behind me it's like Central Station. Two siblings and two parents want to get into this computer. So I've got to vacate this seat — now or I'll be murdered. Write me back soon. Tell me how your "social" life's doing! Your friend forever



Francis  
FRANCIS

*Spice up your correspondence*

recipe of the month



SHORTBREAD

2 Cups butter, softened  
1 Cup fruit/berry sugar  
4 cups all-purpose flour

In large bowl, cream butter thoroughly; beat in sugar until light and fluffy. Gradually stir in all but 1/2 cup of the flour.

Turn out dough onto lightly floured surface. Blend in remaining flour, kneading until dough cracks at edges, about 5 minutes. Roll out half of the dough to 1/4 inch thickness. With floured 2 inch cutter, cut into desired shapes and arrange on ungreased baking sheets. Bake in 300 degree oven for 25 to 30 minutes or until golden. Repeat with remaining dough. Makes 5 to 6 dozen cookies.

*Perfect for clubs, churches and schools*

RESUME

John C. Doe  
11550 East Drive, San Francisco, CA  
U.S.A. 11550  
(415) 543-0293 (residence)  
(415) 925-0000 (business)

GENERAL SUMMARY: Over ten years secretarial and administrative experience. Ability to communicate effectively with all levels, prepared to make decisions and accept responsibility. Strong supervisory skills.

POSITION OBJECTIVE: Executive secretary, Administrative or Office Management. Salary \$25-30K. per annum.

EDUCATION: 1972-1976 San Francisco High School, San Francisco, CA Grade 12 diploma  
1976-1978 St. Mary's College, San Francisco, CA Bachelor's Science Degree.

EMPLOYMENT HISTORY: June 1984 to present—ADDITION RESEARCH FOUNDATION San Francisco, CA ADMINISTRATIVE ASSISTANT to Director Mrs. Carr (June 84 to Present) Primarily responsible for organizing and supervising office of Director. Major activities involve: answering routine correspondence, editing and reviewing all outgoing correspondence, maintaining, coordinating and reporting progress of all special projects, plan and implement study programs for foreign visitors and supervision of those office support personnel.

May 1981 to May 1984—SAMSON MARKETING COMMUNICATIONS INC. San Francisco, CA SECRETARY TO PRESIDENT—Mr. R. Samson (June 82 - May 84) Primarily responsible for coordinating meetings, proposal submissions, budget preparation and secretarial support for President's office. Supervised one employee.

GENERAL SECRETARY (May 1981 - May 82) Activities ranged from taking minutes of meetings, typing reports and correspondence, screening visitors, preparing expense reports and handling routine telephone requests.

July 1978 to June 1981—MUTUAL OF OMAHA, San Francisco, CA SECRETARY - Policy Division Major activities centered on typing correspondence, coordinating meetings, taking minutes and handling phone calls.

PERSONAL INTERESTS: Travel, reading and gourmet cooking.

*References on Request*

*Stand above the crowd. Create a lasting impression*



*Create an entire magazine. PS is the Amiga standard*



*Produce true typesetting with LaserScript (optional)*



*Write an entire book. And don't forget the illustrations*

## Now. Think What PageSetter Can Do for You.

Whatever your application may be, a personal letter, school flyer, campus newspaper, or even a full fledged manual, you'll do it faster and better with PageSetter. After all, PageSetter is the undisputed leader in Amiga desktop publishing. In fact, your user group probably produces its newsletters using PageSetter. Amiga World says: "PageSetter is a very worthwhile program that can be put to use by a wide segment of the Amiga population." Amazing Computing calls PageSetter: "a very strong program with many capabilities." Commodore Magazine calls it: "One of the ten best Amiga software for 1987."

That's why thousands of Amiga owners have chosen PageSetter. David Biebelberg echos the typical user: "PageSetter is powerful, simple and affordable. I had it up and running in minutes." We think you'll have a lot of fun with it.

If you're serious about doing exciting things on your Amiga, get PageSetter. Just think what you'll be able to do with it.



Get your copy of PageSetter at your local Amiga dealer or directly from Gold Disk. Call toll free 1-800-387-8192. In Canada (416) 828-0913. VISA, M.C., AMEX. \$149.95 U.S.

Gold Disk Inc., P.O. Box 789, Streetsville, Ontario, Canada L5M 2C2

*This ad was created using PageSetter  
Requires 512K. Supports all Preferences printers*



## EDITORS' PAGE

Mark

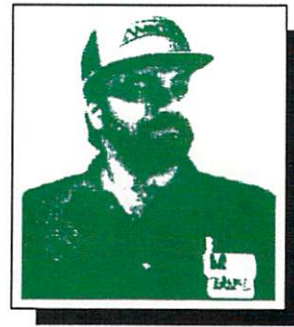

Benn



**ABOUT THE COVER:** Commodore and Amiga users are about to enter the Desktop Publishing (DP) world. At first the exclusive territory of the Mac, then made available (somewhat less elegantly) to the MS DOS users, Desktop Publishing has been slow coming to the Commodore community. That is all about to change. In this issue, we begin our look at the new wave of Commodore-specific DP software with reviews of entry-level Amiga DP packages, a preview of the new GEOS DP system for C64/128 users, and several related items. Next issue we will tackle the "professional" DP titles as well as look at the best of the new crop of laser and PostScript printers which make all this stuff look so good.

Computers were still expensive enough and complex enough to be the exclusive toys and tools of the Yuppie Elite (and most establishment journalists are card-carrying members of the Yuppie Elite). Then along came Commodore, virtually giving away powerful (and fun) computers (the C64 wiped the smiles off many a smug face, then the Amiga 500 totally fried 'em!) Suddenly, anyone who wasn't on welfare could own one of these shining marvels, and virtually anyone who could make Jello could figure out how to use one. The hostility is quite understandable: Commodore gave computers to the common person, and the Old Guard, High Priests, and Yuppie Elite have never forgiven Commodore for giving the Secret Of Fire to the masses.



### Why Commodore is Shunned:

I won't be startling anyone when I say that Commodore is virtually ignored by most general computer magazines, trade publications, newspapers, and TV computer commentators. If you have any doubts, just pick up a copy of InfoWorld, USA Today, Personal Computing, or tune in Computer Chronicles on PBS: if you were visiting from another planet, you would never guess from these high-profile sources that Commodore, at last count, outsells IBM nearly 2 to 1! It used to be generally accepted in the days when CBM ment only VIC 20 and C64 that this was because of the so-called "game-machine" image, but with the advent of serious software and capabilities for the 8-bit machines as well as the arrival and success of the Amiga, how can this continued freeze-out be explained? I have pondered this curious phenomena for some time, and I have developed a theory: Personal computing evolved from a mainframe and "mini" past (when, it took a computer science degree to run a computer, and a corporate bankroll to buy one.) Many individuals in both business and academic circles were overjoyed when the first Personal Computers were introduced- they awed their friends, their bosses, their spouses, and even themselves with their new found power: "Yes, I have a computer, and I know how to use it."



**Then There's That Logo:** What can I say. Apparently some advertising genius found it necessary to try to justify their existence and healthy salary by inflicting the latest fad of graphic design philosophy (that clean, stark look) on the Amiga logo. Now one of the few marketing devices in the Amiga campaign that wasn't broke and didn't need fixin' has been mangled into drabness and given a case of me-too-itis. I'm shaking my head- a company works for years to establish brand name recognition, logo identity, and market visibility- then just flushes it down the tubes, presumably to be fashionable, "with-it", "hey, the now look!" good grief! Maybe I'm just cranky because INFO has been doing Commodore PR work for free these last 4 years, and while Commodore won't spend a nickel advertising with us, they seem perfectly happy spend a small fortune destroying their own good logo. What's a publisher to do? Personally, I think that the old rainbow check mark is too good to let go, and I think it's up to magazines, users, third-party companies, and user groups to keep it alive and held high. It has become the banner and rallying flag of the Amiga community, and we should not abandon it on the whim of some computer- illiterate MBA on Madison Avenue. Are you with me? -Benn & Mark



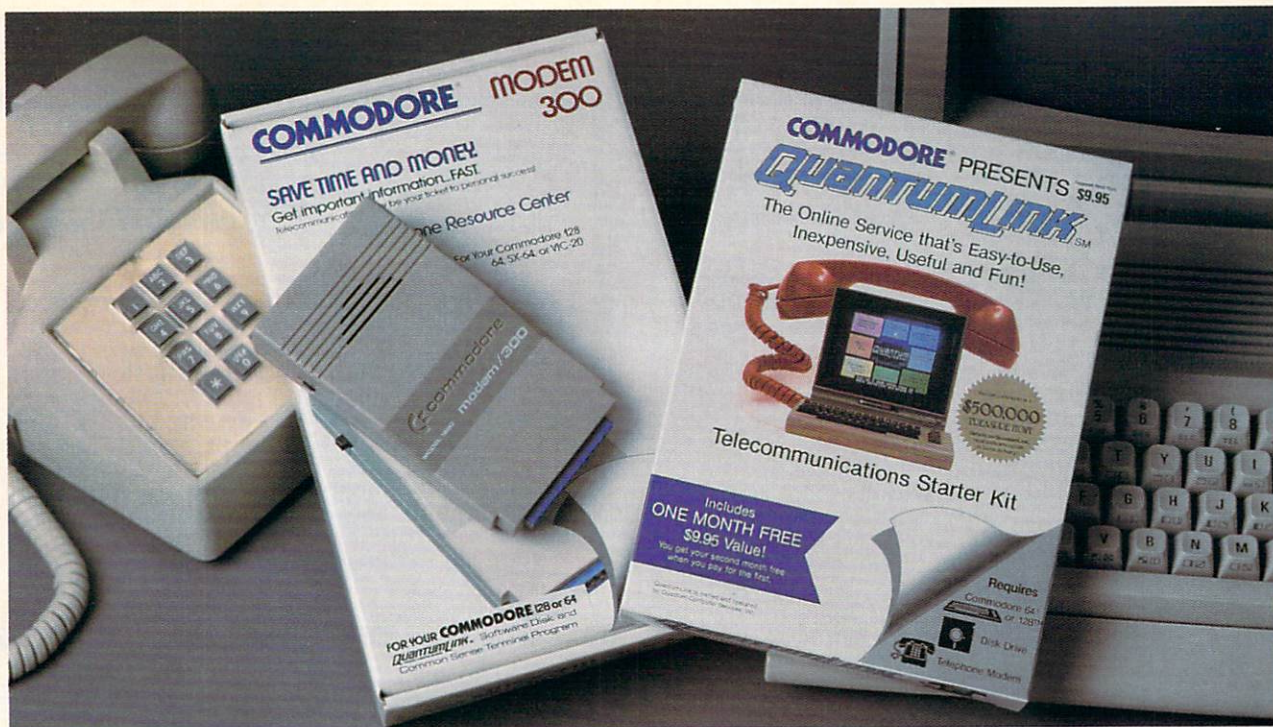

# Bring your Commodore® to life with a **FREE** modem and software!

Now you can plug your Commodore into an exclusive network that's useful, easy, fun and inexpensive. Join Q-Link now and we'll give you a free modem and software to get you started.

Enjoy **unlimited access** to a wide range of Q-Link "Basic" services for a set fee of only \$9.95 a month. Get help from Commodore experts — use the Hotline to ask Commodore questions, or search the database of information from Commodore to answer your questions on the spot. Access Grolier's Academic American Encyclopedia™, the latest news and entertainment updates.

Special Q-Link "Plus" services let you expand your software library with **more than 10,000 public domain programs** — games, graphics, business and educational software and much more! Also, you can preview new copyrighted software before you buy. Get answers to your software questions from Berkeley Softworks, Electronic Arts and Activision, to name a few. Participate in full-color, multi-player games like Casino (includes Blackjack, Poker, Bingo and the Slots), Chess and Bridge. "Plus" services cost only an extra 8 cents per minute — **and your first hour of "Plus" service usage each month is free!**

Offer valid in the continental U.S. and Canada for new members only. Expires 6/30/88. Prices subject to change without notice. There is a communications surcharge for connection to Q-Link from Canada: 6 cents (U.S.) per minute from Montreal, Vancouver, Ottawa, Toronto, Quebec, Windsor, Kitchener and Calgary using the Tymnet network, and 15 cents (U.S.) per minute from over 85 other locations using the DATAPAC network.

Commodore is a registered trademark of Commodore Electronics, Ltd. Q-Link is a servicemark of Quantum Computer Services, Inc. Grolier's Academic American Encyclopedia is a trademark of Grolier Electronic Publishing.

With Q-Link, you can sharpen your computer skills... connect with people... discover new ways to get smart... save money every day... plus have a lot of fun!

**No-risk guarantee.** Try Q-Link without risk. If, at any time, for any reason, you are not completely satisfied, you may cancel your membership.

Order your Q-Link software and modem today by mailing this coupon to Q-Link, 8619 Westwood Center Drive, Vienna, VA 22180 or for faster service call toll-free: **1-800-782-2278 Ext. 1250.**

## Q-LINK RESERVATION FORM

### Choose one:

**I need a modem.** Start my Q-Link membership by charging me now for my first 4 months at \$39.80, and send me the FREE Q-Link software and a FREE Commodore 300 baud auto-dial modem (model 1660—retail value \$69.95).

**I already have a modem.** Send me my FREE Q-Link software and start my Q-Link membership by charging me now for my first month of membership at \$9.95.

Full name \_\_\_\_\_

Address \_\_\_\_\_

City \_\_\_\_\_ State \_\_\_\_\_ Zip \_\_\_\_\_

Homephone \_\_\_\_\_

### Choose your method of payment:

Please charge my credit card.  Check enclosed.  
 Master Card  Visa

Acct# \_\_\_\_\_ Exp. \_\_\_\_\_

Signature \_\_\_\_\_

Call toll-free 1-800-782-2278 Ext. 1250 or mail this coupon to:

Q-Link, 8619 Westwood Center Drive, Vienna, VA 22180



The Commodore Connection.

**GOLDRUNNER**  
MicroDeal  
576 S. Telegraph  
Pontiac, MI 48053  
(313) 334-8729

**INFO-rated**



Very slick hi-speed arcade-style Sci-Fi shoot 'em up. This game is equal to the best of the coin-ops of the genre. The first thing you will notice is how fast everything goes in response to the slightest mouse movements (and that's without the "overdrive" button pressed!). The next thing that hits you is the somewhat haunting and distinctly British digitized voice which encourages you to "hold on, now" and sympathizes with your failures; "don't give up!" I personally find the colors a bit dark and somber. One player. **BD**

**PLUTOS**  
Mindscape  
3444 Dundee Road  
Northbrook, IL 61162  
(312) 480-7667

**INFO-rated**



Another slick tech-look blast-fest, this time for one or two players with joysticks. In addition to shooting the many moving targets (notice the familiar checkered balls?), the player must watch and replenish fuel from time to time. Not what you'd call a real deep game, but it's well done, and superior to most of the arcade quarter-eaters, and the sound effects are great (at least for the first 10 minutes until your ear-drums give out!) **BD**

**TEST DRIVE**  
Accolade  
20813 Stevens Creek Blvd.  
Cupertino, CA 95014  
(408) 446-5757

**INFO-rated**



For only \$50,000 you can own a Porsche 911 Turbo, \$120,000 will get you into a Ferrari Testarossa, and for a mere \$10,000 more you can pocket the keys to a new Lamborghini Countach! A little short on change this month? Never mind; now for the price of a couple of tanks of gas, you can have all three *plus* a Corvette and a Lotus Turbo! Each car has its own handling characteristics, dash, gear-shift layout, radar detector, and rear-view mirror. The game?— Try to motate down the road as fast as you can without wiping out or getting busted. **BD**

**GEE BEE AIR RALLY**  
Activision  
2350 Bayshore Frontage Rd  
Mountain View, CA 94043  
(415) 960-0410

**INFO-rated**



**AIR RALLY** is a harmless, amusing, but disappointingly unambitious airplane race game for one player vs. the computer. Last-generation effects (like the featureless scrolling ground stripes) plus a limited choice of actions (2-speed throttle and constrained range of motion) make this feel more like a childrens' tethered plane-ride at an amusement park than the "joystick-gripping, pylon-shaving" experience promised on the box. If you want real flying thrills, try a commercial flight into Denver or Detroit sometime. **BD**

**KARATE KID PART II**  
MicroDeal  
576 S. Telegraph  
Pontiac, MI 48053  
(313) 334-8729

**INFO-rated**



This familiar but well-done production has you playing the part of Daniel-san in a succession of Karate confrontations and skill-testing interludes. Graphics, music score, and sound effects are nicely done. While the action is two-dimensional (like every other Karate simulation on the market), the body animation is superior, the sounds of various kicks and punches are varied and convincing, the joystick control is natural and responsive, and the background artwork is pleasing and constantly changing. **BD**

**SILENT SERVICE**  
MicroProse  
120 Lakefront Drive  
Hunt Valley, MD 21030  
(301) 667-1151

**INFO-rated**



It's been quite a wait, but at long last MicroProse simulation fans have their first Amiga adaptation. This popular submarine simulation has been somewhat Amiga-sized with the expected improvements in sound and graphics, as well as a rudimentary set of mouse & icon controls (with keyboard and joystick equivalents still operative if you prefer them). The artwork is pretty uninspired compared to stuff like *Psychosis* is doing, but hard core strat/sym buffs will probably never even notice. Personally, I'm saving myself for *GUNSHIP!* **BD**

*continued on page 16...*

# THE GALLERY

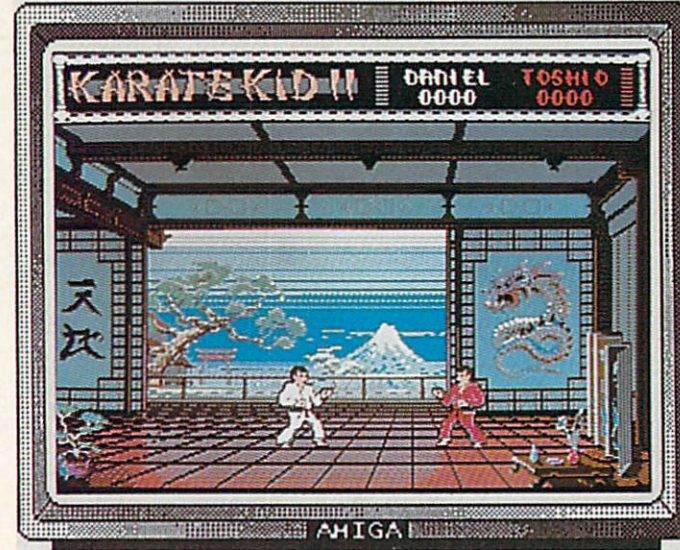
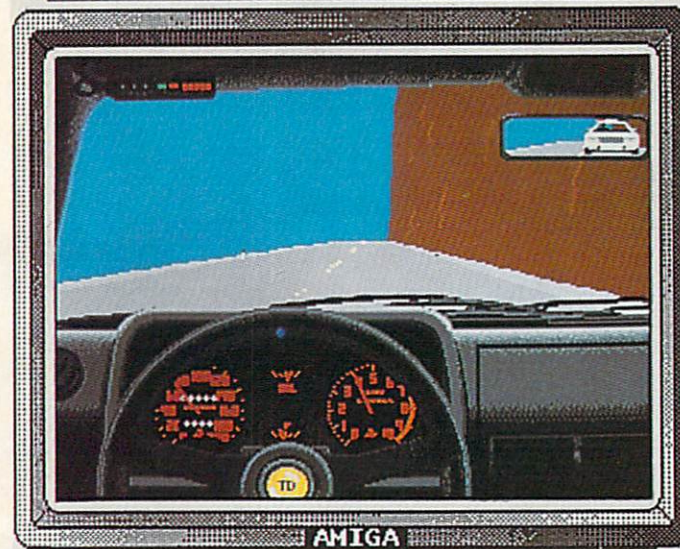
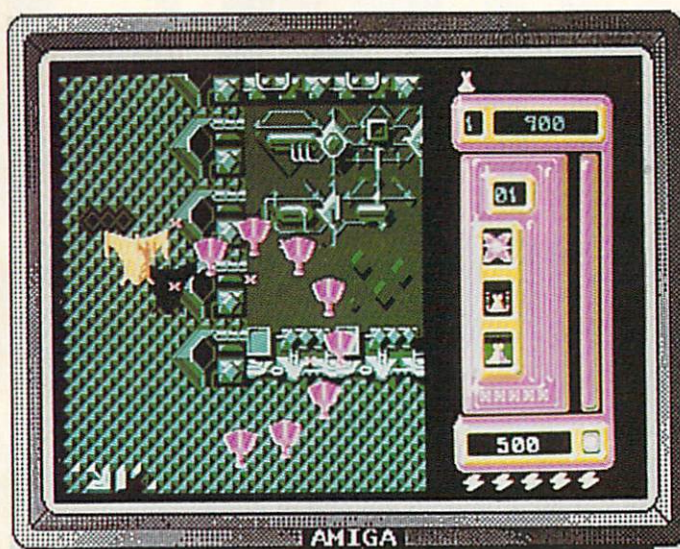

# Skariten

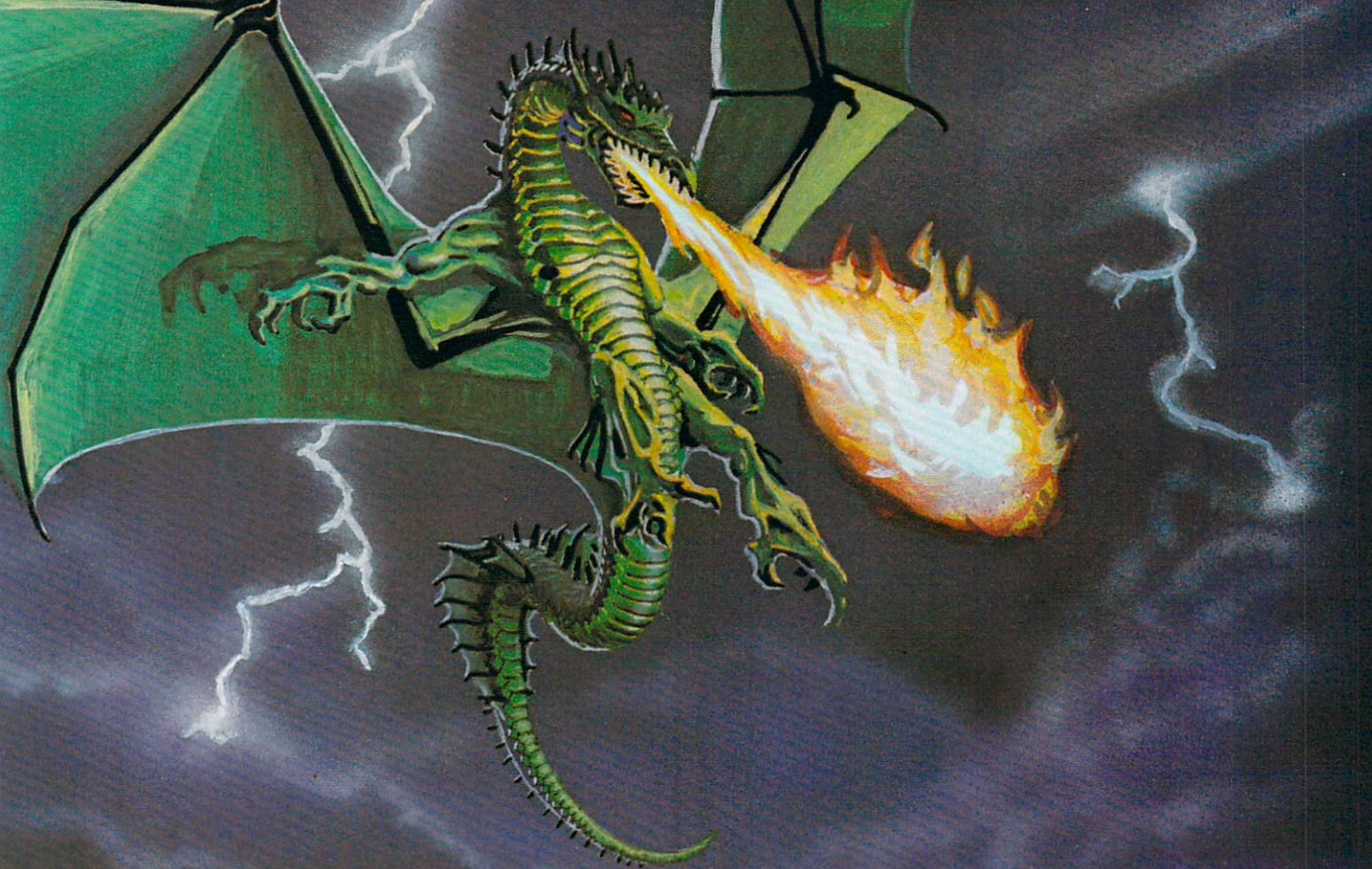

Over thirty separate buildings you can enter, many have more than one floor.



Incredibly detailed map graphics with separate terrain sounds and moving water.

## NEW!

We at Balistic Software have created an adventure game that bridges the gap between computer and player. We have combined exciting angular graphics, battle screens fast enough to make you sweat, and innovative menu driven play which provides a totally new game experience.

## How to order:

Visit your Retailer or call

1-800-255-6910

in Ohio call 1-800-255-6905

Please have your Visa or Mastercard number ready. To order by mail, send \$29.95 plus \$3.00 shipping and handling in check or money order to:



Balistic Software  
2086 Klondike Rd.  
Delaware, OH 43015



There is a 10 day check clearing policy.

For Commodore 64/128

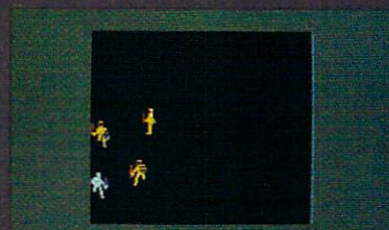

Battles are in real-time, which is extremely rare, and a lot of fun.



Tai'pao, one of the many cities you will find during your quest.

# ABOUT INFO

## A NOTE TO USER GROUPS

We enjoy a really good relationship with lots of user groups across the country. We receive hundreds of user group newsletters, and we read every one of them. We often find items of interest that we pursue and pass along to our readers. If we're not already receiving your user group newsletter, we'd encourage you to put INFO on your mailing list. Our address is: PO Box 2300, Iowa City IA 52244.

We think this free-access information channel should work both ways. That's why we allow user group publications to reprint information from our pages...within reasonable limitations. Unfortunately, we've been disturbed in recent months to see complete articles, pages, and cartoons from INFO reprinted in some user group newsletters. Maybe that means it's time for us to restate our policy. Here goes:

Feel free to use the information you get from INFO in your own original articles in any way you wish. Everybody does it; it's called "research".

If you quote from INFO directly, please give us credit. Something like "from INFO #18, p. 45" will do nicely. Try to keep quotes under a paragraph or so. Please don't string together "quotes from INFO" until they fill several pages of your newsletter!

Don't reproduce whole photocopied pages, cartoons or other artwork, or entire articles without written permission. We're usually pretty lenient about such things, but we like to be asked first. Just write: Mark R. Brown, Sr. Editor, INFO Magazine, 123 N. Linn St., Suite 2A, Iowa City IA 52240. Tell us which article you want to reprint and when, and we'll send back a permission letter within a few days.

We make our living writing and selling magazines. We like to think that what we produce is worth paying for. We hope you agree, and won't pirate INFO. Thanks.

-Mark & Benn

## COMING SOON!

A great subscription deal for user groups!  
Watch these pages for details!

Even WE don't know what the heck it will be yet!

INFO Magazine is entirely produced and managed with Commodore & AMIGA computers, third-party peripherals & software, and simple "lay" equipment (standard 35mm cameras etc.)

We use no Macintoshes, no typesetting service, no industrial equipment, (or mirrors!) We do our wordprocessing, illustrating, accounting, mailing labels, data management: EVERYTHING with this stuff! In short- everything you see in these pages you could do yourself at home with easily found products available to the average consumer at a relatively modest cost. We are committed to this approach for several reasons: 1) it's cheap, 2) turn-around times from news to print are incredibly short, 3) we feel that using these products every day in "real-life" is the best basis for reviews and comparisons, 4) it's a blast!

INFO began in 1983 and was originally produced quarterly (sort of) by one person working out of a spare bedroom with one C64, a dot-matrix printer, one disk drive, crude software, and absolutely no publishing experience (see Issues #15 & #16 for the complete lurid history). INFO is now produced bi-monthly by a core group of 5 regular all-purpose computer nerds out of a renovated brewery in beautiful Iowa City, IA.

Our mission is to keep making a living doing what we love best (computing) by giving you hard-hitting reviews you can trust, late-breaking news, informative and fresh articles, and a healthy dose of satire and humor. We don't publish type-in programs that waste your time and money, we don't wear suits, we don't take any guff from advertisers, and we don't take American Express!

### What the Ratings Mean:

INFO-rated

★★★★+

★★★★★ Super! Sets the Standard. Tops in its Class!

★★★★ Excellent! Has Extra Features and Good Feel!

★★★ Average. Standard Features, no Bugs, no Extras.

★★ Lacks Features, or is Hard to Use, or has Bugs.

★ Worth the Price of the Disk Alone!

**NEED A  
GOOD  
WORD ?**



LET YOUR COMPUTER  
HELP YOU FIND IT  
WITH OUR

*NEW TESTAMENT  
CONCORDANCE*

*King James Version*

**\$49.50**

Plus \$2.00 for shipping and handling

FOR COMMODORE 64/128 OR  
APPLE IIe, IIC

VISA/MASTERCARD

ORDER LINE 9:00 A.M. to 5:00 P.M.

**1-800-422-0095**

MICHIGAN AND AFTER 5:00 P.M.  
**(313) 477-0897**

**MIDWEST SOFTWARE**

Box 214 • Farmington, MI 48332

## A Powerful Wordprocessor for the Commodore 128®

# Font master 128



Selected  
for the 1987  
CES Software  
Showcase  
Award.

From the author of **Fontmaster II** comes **Fontmaster 128**, an enhanced version for the Commodore 128. This powerful word processor with its many different print styles (fonts), turns your dot matrix printer into a more effectual tool. Term papers, newsletters, and foreign languages are just a few of its many applications.

- \* Program disk with no protection - uses hardware key
- \* Supplement disk includes foreign language fonts
- \* 56 Fonts ready to use
- \* Font editor/creator included
- \* On screen Font preview
- \* 80 column only
- \* Supports more than 110 printers
- \* *Includes a 102,000 word Spell Checker*

*Only*  
**\$69.95**

Commodore 128 is a registered trademark of Commodore Business Machines, Inc.

**ACI** Inc. 2804 Arnold Rd. Salina, Ks. 67401 (913) 827-0685

### Knowledge will Increase many shall run to and fro-Daniel 12:4

Of man's inventions, the printing press has benefited the WORD more than any other. Now, the personal computer offers a new innovation in the presentation and study of the BIBLE! LANDMARK The Computer Reference Bible can actually HELP in your study by assisting you in gathering text and keeping permanent and organized notes and references. LANDMARK TCRB can enhance your Bible Study in three major ways:

- Searching the Bible for words, phrases or sentences.
- Creating your own Topical Files covering a Bible Study topic. Your LANDMARK files can even be converted for use in wordprocessors like Paperclip and GEOS (with Writer's Workshop)!
- Creating your Personal Bible(s). You can outline text in color, add notes to the individual verse references or directly to the text and create supplemental study files.

### NEW C64 UPDATE!

C128 Owners! Version 2.0 is now being developed, and will be added to the C64 version! *LANDMARK The Computer Reference Bible consists of the entire King James version with Individual Verse References, the Words of Christ in color, and a Concordance of 3300+ words!* LANDMARK TCRB for the Commodore 64/128 (in 64 Mode) is **\$164.95**

CALL or WRITE for our FREE Brochure!

P.A.V.Y. Software P.O. Box 1584  
Ballwin, MO 63022 (314) 527-4505  
**DEALER INQUIRIES INVITED!**

GEOS and Writer's Workshop are registered trademarks of Broderbund Software. Paperclip is a registered trademark of Broderbund Software. Commodore 64/128 are registered trademarks of Commodore Business Machines, Inc.

## DARE COMPARE



MICRO R & D  
INCORPORATED  
3333 S. WADSWORTH  
LAKEWOOD, CO 80227  
(303) 985-1473

## MW - 350

2K  
or  
10K

Introducing ultimate performance in a printer interface-quality, flexibility and rugged construction. Featuring the all new 1.91 ROM.

### MW 611 I/O Board

16 Analog inputs  
16 Discrete outputs  
1 Analog output  
eprom socket for user programs  
prototyping area set aside for  
your applications.

**ONLY \$225.00**

# We Won't Be **UNDERSOLD**

\* On items marked "No One Sells This ----- For Less". Copy of valid ad required.

15 Day Free Trial • 90 Day Immediate Replacement Policy • Prices Expire 1-30-88

## Genuine IBM® Printer

8½" Letter Size • 80 Column  
Limited Quantities

**No One Sells  
This Printer  
For Less!**

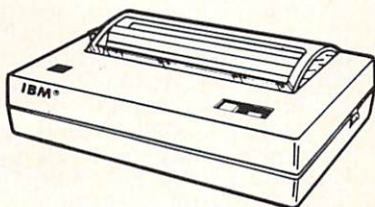

1st Come  
1st Serve

**Sale \$499.95**  
(Add \$7.50 shipping. \*) List \$199

- Unbelievable Low Price
- Advanced Dot Matrix - Heat Transfer
- Upper & Lower Case (With True Lower Descenders)
- Graphics With Commodore, Apple & Atari Interfaces
- Ready to Hook Up To Serial Port Of IBM® PCjr
- Low Cost Adapters For IBM®, Apple, Commodore, Laser, & Atari Computers
- Underline
- Enlarged

## 22 CPS Daisy Wheel

13" Daisy Wheel Printer With  
True Letter Quality

**No One Sells  
This Printer  
For Less!**



Typewriter  
Quality

**Sale \$999.95**  
(Add \$10.00 shipping. \*) List \$499

- Daisy Wheel Printing
- 22 CPS, AAA Text
- 13" Wide Carriage
- Both Daisy Print Wheel & Ribbons Compatible with Diablo™ & Qume®
- Single Sheet or Continuous Feed
- Parallel Centronics Port
- True Letter Quality
- Below Wholesale Cost

## Super Hi-Speed Printer

200 CPS Star Micronics LV-2010  
With Crisp Near Letter Quality

**No One Sells  
This Printer  
For Less!**

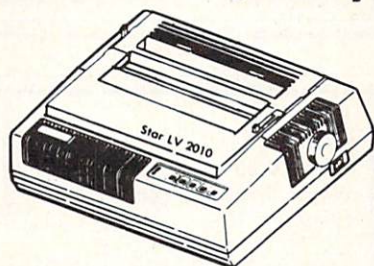

**SALE**

**Sale \$209.95**  
(Add \$10.00 shipping. \*) List \$499

- 200 CPS Draft - 45 CPS Near Letter Quality
- Serial Impact Dot Matrix
- IBM Compatible
- Near Letter Quality Mode
- Ultra High Resolution Bit Image Graphics
- Pull Tractor & Automatic Single Sheet Loading
- Standard Serial & Centronics Parallel Ports
- Continuous Underline

## Ultra Hi-Speed Printer

300 CPS Draft • 50 CPS NLQ  
With Color Printing Capabilities

**No One Sells  
This Printer  
For Less!**



Color  
Printing  
Capabilities

**Sale \$299.95**  
(Add \$10.00 shipping. \*) List \$499

- 300 CPS Draft - 50 CPS Near Letter Quality
- Front Panel Margin Setting
- Download Character Setting
- Variety Of Characters & Graphics
- Parallel & Serial Interface Ports
- Auto Paper Load & Ejection
- Optional 7-Color Printing Kit ..... Sale \$99.95
- Epson/IBM Modes
- Bottom Feed
- 10K Buffer

**COMPUTER DIRECT** (A Division of PROTECTO)

22292 N. Pepper Road, Barrington, IL. 60010

Call (312) 382-5050 To Order

We Love Our Customers!

\* Illinois residents add 6% sales tax. All orders must be in U.S. Dollars. We ship to all points in the U.S., CANADA, PUERTO RICO & APO-FPO. Please call for charges outside continental U.S. or C.O.D. MAIL ORDERS enclose cashier check, money order or personal check. Allow 14 days delivery, 2 to 7 for phone orders and 1 day express mail. Prices and availability subject to change without notice. (Monitors only shipped in continental U.S.)

VISA — MASTERCARD — C.O.D.

CHUCK YEAGER'S  
ADVANCED FLIGHT TRAINER  
Electronic Arts  
1820 Gateway Drive  
San Mateo, CA 94404

INFO-rated



If you are any kind of flight-simulator fan at all, you are going to love this title! It's the ultimate, prime, triple-A, C64 flight-sim. Choose from 11 real aircraft (SR-71, F16, Cessna, Spad, Spitfire etc.) and 3 experimental craft. Test fly, race, fly formations or aerobatics. Uses different aerodynamics for each aircraft. Many more options than SubLogic's famous title, fast animation, and plenty of running commentary from Chuck Yeager himself make AFT the new standard to match! I only regret that the "instant replay" feature wouldn't fit in this version. BD

THUNDER CHOPPER  
ActionSoft  
122-4 S. Race St.  
Urbana, IL 61801  
(217) 367-1024

INFO-rated



ActionSoft has now gone head-to-head against two very good MicroProse simulations: Up Periscope tied dead even with Silent Service in the submarine simulation competition, Thunder Chopper is not quite the equal to its predecessor, Gunship, in either detail, instrumentation, graphics, or game play. It easily the second-place holder, however, and persons looking for a more casual relationship with a helicopter may actually prefer Thunder Chopper's more simplified rendition. Choose from training, combat, and rescue missions. BD

BEYOND ZORK  
Infocom  
125 Cambridge Park Dr.  
Cambridge, MA 02140  
617-492-1031

INFO-rated



Even if the feel is more like Wishbringer than Zork, it's great to see the familiar Frobozzian names again. The plot revolves around finding a coconut. Really. A vastly improved user interface makes it a pleasure to play, and windows, an onscreen map, and the best parser in the business make it faster, too. I mildly object to the RPG-type character attributes, but they do add a new variability to the game. A little too much emphasis is placed on exotic monsters and fighting them, but overall the game is bestseller calibre, even if it isn't quite up to the original Zorkian standards. -TM

CHERNOBYL  
COSMI  
415 N. Figueroa  
Wilmington, CA 90744

INFO-rated



The name of this game is misleading. Rather than a cheap exploitation of the Chernobyl disaster (which is what I was expecting), Chernobyl is a pretty decent simulation of real-life nuclear power plant operations. The graphics screens are justenough, and the sound effects are excellent! The manual thoroughly details nuclear power plant operations, but you MUST print out the on-line manual of game-play commands if you want to succeed in keeping the plant on-line. Not as ambitious for author Paul Norman as his SUPER HUEY titles, but a nice, engrossing, even educational title. -MB

SKATE OR DIE  
Electronic Arts  
1820 Gateway Drive  
San Mateo, CA 94404  
(415) 571-7171

INFO-rated



And, if you're more into skate-boarding than hitting Mach 3, this has to be the ultimate for you. This is a tough quintette of game-ettes in which the losing character is generally seriously injured or worse! Skate or die is rendered with a distinct flavor of punk violence which will alarm many parents and probably delight as many kids. The game-play is actually quite sophisticated with a real sense of control and fairly decent physics. Skate or die plays very well with the computer as opponent, or plug in a friend with a second joystick and have at each other! BD

ECHELON  
Access  
2561 S 1560 West  
Woods Cross, UT 84087  
801-298-9077

INFO-rated



This "3D Space Flight Simulator" is too slow for true flight simulation or arcade shoot-em-up action. You MUST turn off the display grid to get acceptable speed out of this game. The included 'Lipstik' voice-activated firebutton is more sorely needed on some other, faster arcade games. Lots of detail, but maybe Echelon should have been billed as an adventure game--the hunt for clues to the hidden pirate base is the most engrossing aspect of the game, but not the high-speed romp that arcade players will expect. Nice ref. card and manual. -MB



# THE GALLERY

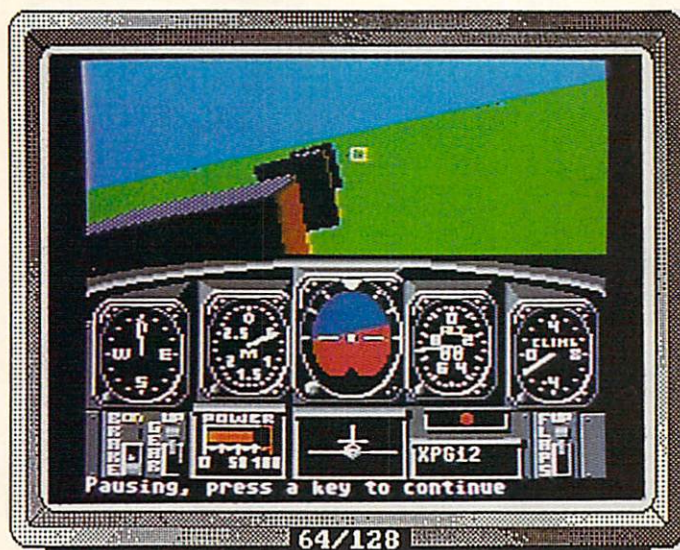

64/128

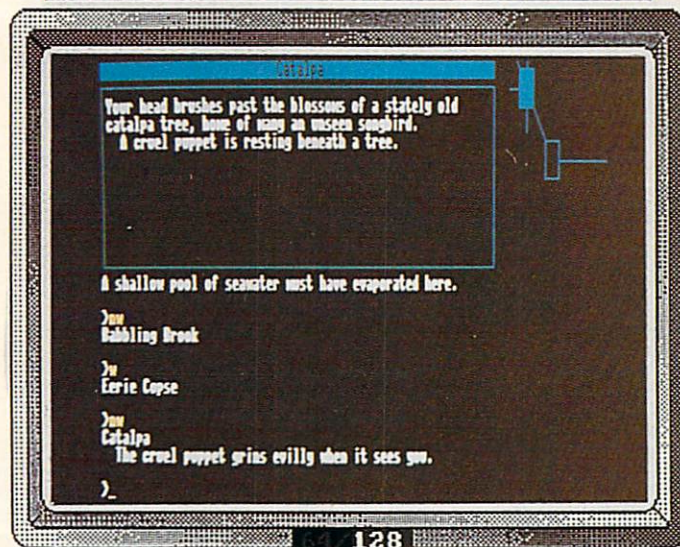

128

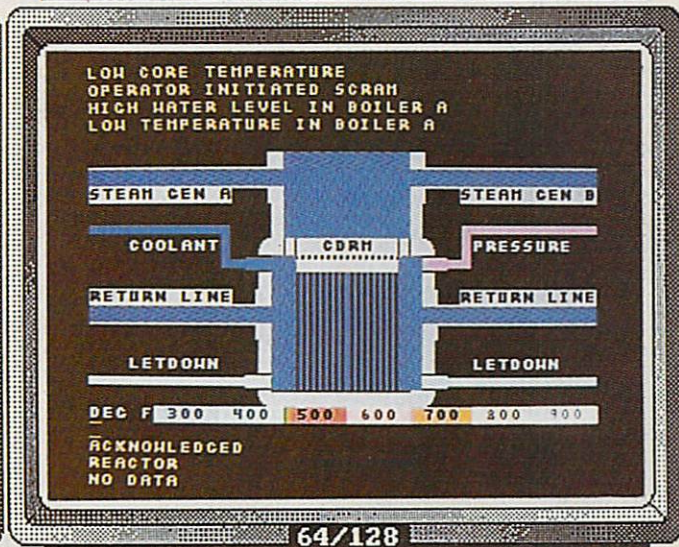

64/128



**RAD WARRIOR**  
Epyx  
600 Galveston Drive  
Redwood City, CA 94063  
(415) 366-0606

**INFO-rated**



Some very exceptional graphics distinguish Rad Warrior from most of the "economy-line" series put out these days by most major software houses. Plot and gameplay are pretty standard, but there are enough of surprises and challenges to keep veteran stick-grippers occupied. Enter the radioactive future world of 2500 A.D. Wrestle the various "wasteoid" mutants for weapons and artifacts, then make your way to and destroy their heavily guarded nuclear power source. For one player only. BD

**THE LAST NINJA**  
Activision  
2350 Bayshore Frontage Rd  
Mountain View, CA 94043  
(415) 960-0410

**INFO-rated**



What really sets LAST NINJA apart from the other dozen or so martial arts games is the unique "3D" oblique perspective view which allows your black-clad hero to move thru a much more realistic world than we are normally used to seeing on screen. NINJA includes over 130 screens, 1000 animated figures and objects, and 6 different sound scores. The art and graphics design are very good, and the combat animation is better than average. Watch where you're swinging those numchukas! BD

**REVS +**  
Firebird  
PO Box 49  
Ramsey NJ 07446  
(201) 444-5700

**INFO-rated**



What REVS + lacks in graphics detail, it makes up for in realistic & detailed response and operation. Six real-life race courses have been carefully modelled (in data terms, not visually), and a fold-out map is included for reference. The race car is simulated to a high degree of functional realism too, with inter-related clutch, gears, throttle, and steering create a surprisingly convincing driving experience. Support for for either A or D joysticks, paddles, or keyboard control, plus a wide range of options, including computer-aided steering. BD

**TEST DRIVE**  
Accolade  
20813 Stevens Creek Blvd.  
Cupertino, CA 95014  
(408) 446-5757

**INFO-rated**



The 64 version of TEST DRIVE is pretty much the equal of the AMIGA version except for a few hundred pixels: the action and responsivity are very close. Again, you have your choice of five of the hottest and most expensive cars on the road today, and you can take turns driving them all at lethal speeds (and without insurance!) Since it is hard to read the analog speedometer and tachometers, a digital display may be toggled on and off for clarity. The functional rear-view mirror is a kick, (especially the first time you see Smokey flaggin' you down in it!). BD

**FOURTH & INCHES**  
Accolade  
20813 Stevens Creek Blvd.  
Cupertino, CA 95014  
(408) 446-5757

**INFO-rated**



I don't know about the statistical virtuosity or elegance of programming under the surface, but for my money, 4th & Inches is probably the most enjoyable electronic incarnation of the Great American Pigskin Preoccupation. Plays are a "snap", with 11 formations and 20 plays available at the jerk of a joystick. Player control is smooth and intuitive, giving the best sense of actually playing the game I have seen yet. Coaching screen allows player selection and substitutions. Play the computer or a friend with a second joystick. BD

**MINI-PUTT**  
Accolade  
20813 Stevens Creek Blvd.  
Cupertino, CA 95014  
408-446-5757

**INFO-rated**



Let's get unserious for a while. If you're looking for something to get hooked on, this is it. Bouncing a very lively ball around elephants and off windmills is wildly hilarious fun. Yes, it's miniature golf as it ought to be. Using the same three-click user interface as Accolade's Mean 18, the game is extremely well designed, simple to learn, and impossible to master. It requires a lot of finesse, some luck, and the best day you've ever had for a low score. Four courses are provided, with more on the way. Fine animation, good sound, and attention to detail make this a classic. -TM

# THE GALLERY

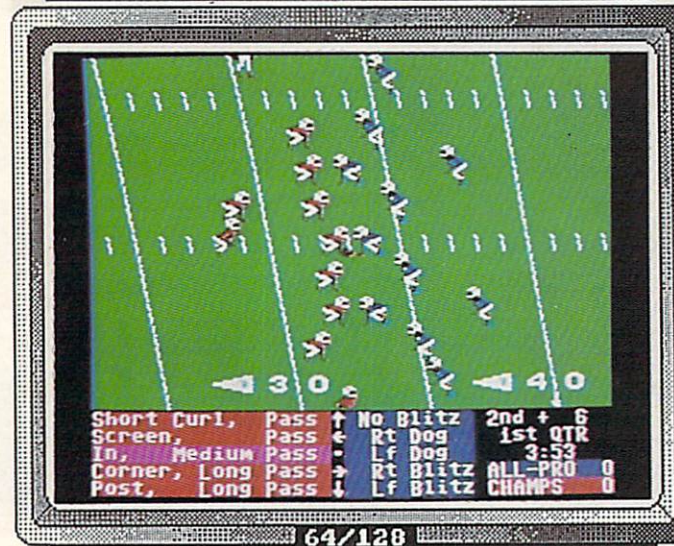
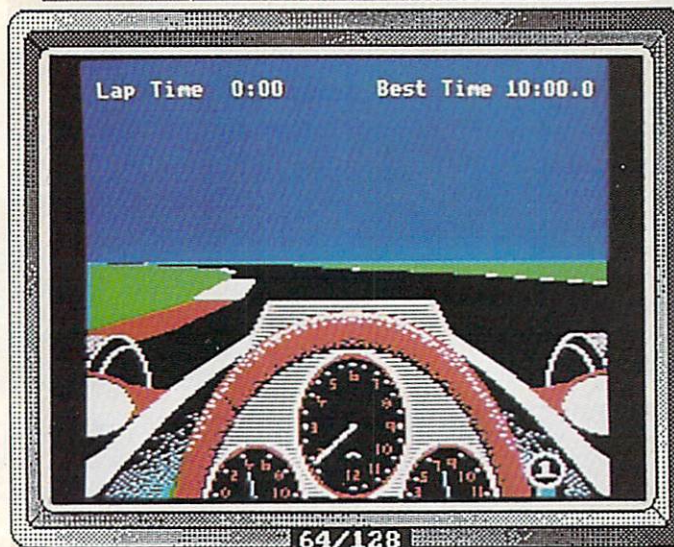
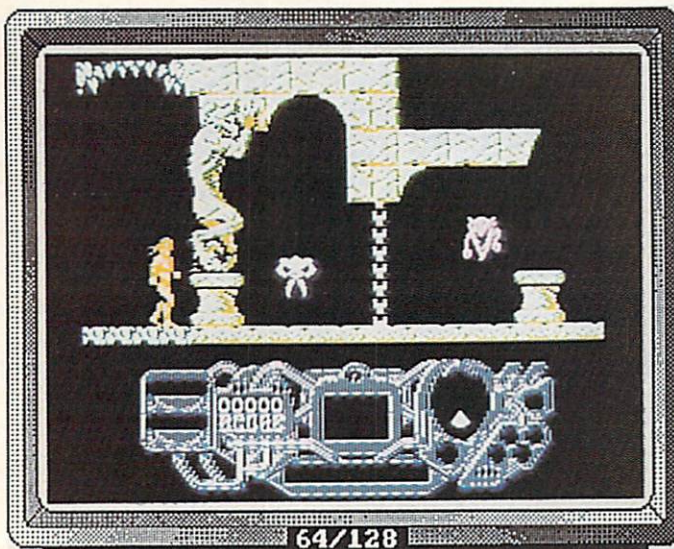

**INTRODUCING...**



Supra Corporation, a leading manufacturer of computer peripherals for Atari and other personal computers has obtained the exclusive license to manufacture the Cardco line of products.

Cardco has been hailed by many computer magazines as the standard by which competitors should be measured. At Supra Corporation, we plan to maintain this leadership position in the Commodore accessory market by providing complete product documentation, unequaled customer service, and a product line second-to-none.

We will continue to carry on research and development to create innovative state-of-the-art software and accessories for Commodore computers. These products will help you enjoy your computer more and increase it's value.

**"World's Largest Manufacturer of Commodore Accessories"**

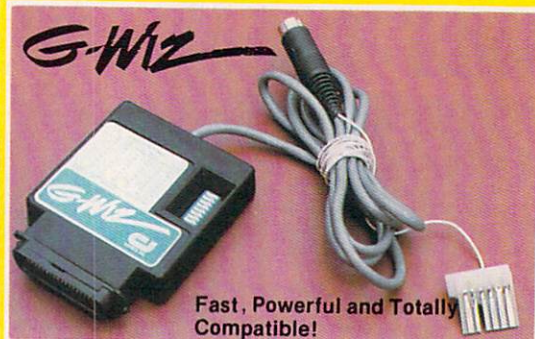

Fast, Powerful and Totally Compatible!

A centronics parallel interface with full **keyboard graphics**. The G-WIZ works with most common printers and can do screen dumps in 2½ minutes with its built-in-buffer. Plugs directly on to printer. **\$49.95**

**SUPER G**

High Speed Parallel Printer Interface with Graphics Buffer and Full Commodore Graphics Emulation - Built-in buffer for super fast graphics printing. Full Commodore character set, including all graphics, reversed text and reversed graphics characters. **\$69.96**

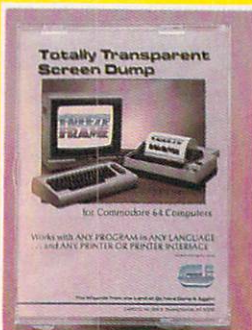

**FREEZE FRAME**

**Totally Transparent Screen Dump**  
This cartridge dumps screen memory graphics to a printer with only two key strokes. Works with any program in any language. **\$49.95**

**S'MORE**

Adds over 60 new and enhanced BASIC commands and 57% more free RAM memory for programming. **\$49.95**

**OTHER COMMODORE PRODUCTS**

- 1064 Modem 49.95
- Cardco B Interface 39.95
- Cardco PS Interface 69.95
- Cardco +G Interface 49.95
- CB-2 Expander 24.95
- Freeze Frame 49.95
- S'More 49.95
- CardKey Numeric Keypad 29.95
- Write Now! 29.95
- Spell Now! 29.95
- Calc Now! 29.95
- File Now! 29.95
- MicroStuffer 69.95
- 64K Printer Buffer

**cardboard**

**Expansion Interface**

Also for C-128

An enclosed five slot, fully switch selectable expansion interface for the Commodore 64. Allows the user to select any cartridge slot or combination of cartridge slots. Convenient reset button. **\$39.95**

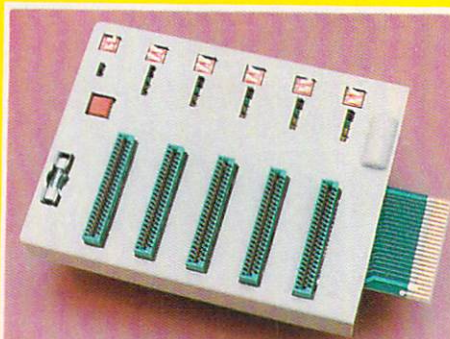

A Cardco Product

Available at your local dealer, or call:

**Supra Corporation**

1133 Commercial Way / Albany, OR 97321

(503) 967-9075-Orders

(503) 967-9081-Technical Support

Telex: 5106005236 (Supra Corp.)

# INFO UPDATE

## NEWS UPDATES

Berkeley Softworks has turned over their online QLink GEOS document laser-printing service to the folks at *GeoWorld* magazine. The process and rates are the same: you upload your document to QLink, get charged \$3 for the first page and \$1 for each additional page +\$.25 handling and full postage. You get your GEOS document mailed back printed on an Apple Laserwriter. The new service is promising much faster turnaround than BSW provided. Full details are available online.

We've had some questions about how much a used MSD-2 dual disk drive is worth. The MSD Information Exchange (2705 Hulman St., Terre Haute IN 47803) indicates the current street price is about \$150, if you can find one.

We hear the best price being paid for used SX-64s is coming from "some company in Ohio that remanufactures them into \$2000 medical monitors". Sorry, we don't know the name of the company.

A1000-for-A2000 trade-in deals are happening all over the country. Savings range from about \$450 to \$1000. Some dealers will even sell you back your A1000 at a ridiculously low price. Shop around--no telling how long the deals will last.

Even though the color monitor is not yet available for the Mac II, they are still selling lots of Mac IIs. Dealers estimate the average Mac II buyer is spending \$10,000 on his system. Remember: that's without monitor.

In *New Products* last time we listed a "coming attraction" from MicroProse called *Destroyer Escort*. It turns out that it will not be produced; it was taken out of development some months ago.

## MOVES

After some bouncing around between distributors, it seems that the *Excelerator* 1541-clone drive will now be sold by SCI, PO Box 1836, Capitola CA 95010, (408) 462-9494.

Spectrum Holobyte (the *GATO* people) now distribute *Intrigue* for the C64, reviewed in last issue's Gallery.

NewTek has moved. Their new address is 115 W. Crane, Topeka KS 66603, (913) 354-9332.

InConTrol has moved. Their new address is 100 Sunset Dr., Chambersburg PA 17201, (717) 267-1879.

## SOFTWARE UPGRADES

*...Update/upgrade prices are for registered owners upgrading to the latest release. Original purchase prices are higher.*

Datasoft's *Video Title Shop* for the 64 is now out in v2.0. It includes continuous-loop, abort-sequence, and display-while-loading enhancements. Updates are \$7.50.

There are new versions of some of the C64 copy programs: *Copy II 64/128* is up to version 3.1 and will now copy *Skyfox*, *Marble Madness*, *Carmen Sandiego*, and many more new titles. The update is \$18. The latest version of *Ultrabyte*, with 105 tough parameters, is v4.0. It's \$15 ppd. plus the old disk to upgrade.

New Horizons has released an upgrade to their *Flow* outline processor for the Amiga. It adds full-paragraph headings, file-list for requesters, enhanced printing, better search, and user-definable indentation. Updates are \$20 if you bought before Aug 1, \$10 if you got it more recently.

EA has modified several of their programs to work with v1.2 of the Amiga's operating system. Programs that have gone through the "change" are *Instant Music* (\$12), *Deluxe Video* (\$37), *Deluxe Print* (\$12), *Skyfox*, *Arcticfox*, and *The Bard's Tale* (\$7.50/ea). Upgrades to *Archon*, *Archon II*, and *7 Cities of Gold* are in the works. Prices in parentheses are upgrade costs.

Lattice is up to v4.0 of their *Amiga C Compiler*. This latest version produces faster, tighter code, and now includes more than 250 library function calls. The upgrade is \$75, free if you bought after Aug. 1.

*Gizmoz v1.2* from Digital Creations has some nice additions and enhancements. *SuperLife* is much faster, with more display options. The term program has a great many options, and is probably enough for most casual users. The calculators, icon maker, fastprefs tool, hot key tool, even the cuckoo clock...it's a nice collection.



**Be an INFO Emissary!**  
When you order products from our advertisers,  
tell them you saw it in INFO.

# VIRUS!

by Mark R. Brown

Technical Editor

Viruses are nasty little things. Some of them are just annoying--they make you sniffle a little for a day or two and then are gone. Some make you very sick. Some are fatal. But they all share two things in common: (1) they're *never* good for you, and (2) you can pass them on to others.

It may seem surprising, but there are viruses for disks, too. Members of the IBM community are familiar with them. Disk viruses are short programs that live on the boot sectors of a disk in places where the operating system usually resides. They infect a computer when the system is booted up, and move themselves into an inconspicuous unused area of memory where they can sit undetected and do their damage.

Some disk viruses are pretty innocuous. They sit around for a while and then take over the computer for a moment, print some unnerving message on the screen, and then return control of the machine to the operator.

Other viruses are not so benign. We won't list the possibilities because we don't want to give anyone any ideas. Let's just say that they can seriously affect the utility of your system.

All viruses are transmittable. That is how they get into your system in the first place. They sit in memory, looking for disks that don't have the virus on them yet, then write copies of themselves to the new disks. This makes them a carrier of the disease, able to infect new computers and new disks. They *have* to be able to infect disks in order to replicate and survive--because the computer itself is "cured" as soon as it is shut off. Computer viruses live in volatile system RAM.

## THE AMIGA VIRUS

We booted up a copy of *WordPerfect* on one of our Amigas the other day and instead of the familiar CLI screen, we were surprised to see this message flashing across the screen in white letters on a red stripe:

*Something wonderful has happened...Your AMIGA is alive!!!...and, even better....Some of your disks are infected...by a VIRUS !!!*

We were more than a little concerned. This was the first Amiga virus we had seen and we didn't know three very important things about it: (1) Could we get rid of it?, (2) How many disks were infected?, and (3) How much damage did this particular virus inflict on the system?

Some time spent asking questions up on the networks revealed that many Amiga users had

Something wonderful has happened

Your AMIGA is alive !!!

and, even better...

Some of your disks are infected

by a VIRUS !!!

found infected disks in their collections, too, all at about the same time. We found out that Commodore was not only aware of the problem, but they have a man working on detecting the virus and developing a cure.

## THE FACTS

There's a credit line in the virus's message (there always is: the jerks who write these things do it for the notoriety) that says the hack is the work of the "Mega-Mighty SCA!" The SCA is none other than the infamous Swiss Crackers Association, a European pirate organization. There's some indication that it may have made its way to the U.S. on a pirate copy of the German game *MouseTrap*.

When you boot with an infected disk, the computer stays infected until you power it down. Every time you warm boot the system with a Control-Amiga-Amiga, this virus interrupts the process and checks to see if the disk in drive df0: is infected. If not, it writes a copy of itself to the boot sectors of the new disk and increments an internal counter. Once it has infected 16 or so disks in a single session, it displays its "Wonderful Thing" message, then goes on with the normal boot sequence.

## DETECTION

The virus is a small snatch of code that lives on block 1 of a bootable (that means *Workbench*) disk. You can see it with a track and sector editor by looking at Cylinder 0, Head 0, Sector 1. Commodore's "Virus Doctor", Bill Koester of the Commodore Amiga Technical Support staff, has written a program that will detect the virus on any disk. It's called VCheck1.1 and is available on PeopleLink, BIX, and CompuServe. I strongly suggest that all user groups download a copy and make it available to their members.

## DANGERS

Fortunately, as viruses go it looks like this one is relatively benign. Koester has disassembled the majority of the code, and it seems to do no permanent damage to disks other than changing the boot sectors. The only interference it causes is that occasional annoying message.





Here's what you've been missing in the other magazines the past couple of months:

## Ahoy!

AHOY!'s Amiga section has shrunk from a high of 10 pages to 4 or less, just enough space for 2 reviews. Mort the K dissects C64 memory dump cartridges in the Nov. issue while Dale Rupert presents part II of BASIC data structures. In Dec. Dale looks at AI while Morton digs into Swisscomp's 65C816 Turbo Processor and tutors readers on the user port.

## RUN

RUN and COMMODORE remain the last strongholds of BASIC and BASIC & m/l hybrid type-ins. In the Oct. issue, RUN Tech. Editor Tim Walsh ends up recommending all the database managers in a 6-product "comparison". Dennis Brisson's editorial on the early days of the PET in the Dec. issue is entertaining, if inaccurate in decreeing The Midnite Software Gazette "defunct"; Barbara Mintz presents a nice RUNdown of software that supports the 1351 mouse and Commodore REUs. RUN's 4th annual special issue is out, with all of 1987's Magic Tricks in an organized, indexed form.

## COMPUTE!'S GAZETTE

On page 82 of the Nov. CG is a m/l program not in boring old hex, but in commented assembly language! A big tip of the hat to Rhett Anderson and David Hensley, Jr. who write "The GEOS Column" for bringing a couple of educational pages into the GAZETTE! CG retires Richard Mansfield's "Inside M/L" column with the Dec. installment--it's been there since Vol.1, No.1. Jim Butterfield takes up the slack with "M/L Programming" starting in Jan. The Nov. and Dec. issues each, incredibly, contain yet another SpeedScript enhancement program.

## commodore

Part 8 of the AmigaBASIC Tutorial, part 6 of the User Port Tutorial, an interesting look at some of the weirder BBSs by Dan Gutman, and more short, sweet BASIC type-ins help make the Nov. issue good reading.

## The Transactor

Don't miss Jim Butterfield's article on programming the Amiga's CLI cursor in the Nov. issue--it's a blast! The big news at TRANSACTOR is that they are splitting the magazine into separate 8-bit and Amiga titles. January will mark the debut of the AMIGA TRANSACTOR. Each edition will publish 6 issues a year, on alternating months. The new mag will cost \$15/yr U.S., \$19/yr Canadian, just like the old one. 85 W. Wilmot St., Unit 10, Richmond Hill ONT Canada L4B 1K7, (416) 764-5273.

## Money Machine Magazine

MM is up to 56 pages with issue #4; it contains reviews of Publisher 1000 (less than favorable), Pocket Planner 2, BEST Business Management, GEOS, and more, and includes a list of 300 home business ideas. MM covers business & productivity on all Commodore computers. \$16/yr (6 issues), Blair Bldg., 1301 NE 14th St., Ocala FL 32670.

## Amazing Computing™

V2,#10 concentrates on Programming, with looks at C, Pascal, BASIC, Modula-2, M/L, and more. John Steiner launches a new column called "Bug Bytes" to keep up with product bugs and revisions. V2,#11 marks the debut of color throughout the pages of AMAZING. The focus is on wordprocessors. You'll be seeing less of John Foust in the future--he's resigned as Tech Editor to concentrate on consulting work and start his own software company.

## ROBO CITY NEWS

FIRST AMIGA USERS GROUP

The Aug. RCN has a nice article by Rob Peck that tells what hasn't been done in Amiga demo programs yet. The Sept. issue features a cover shot of Leo Schwab's infamous "Amiga ball juggling 3 unicycles" animation and the entertaining story of its creation. Oct. features a great takeoff on Jerry Pournelle's Byte column, and a useful article from Bryce Nesbitt on common Amiga programming mistakes. Each issue is packed with news and tidbits and lives up to RCN's "...less fluff, more stuff." trademark. \$18/yr., 543 Old County Rd., San Carlos CA 94070.

## The Amiga™ Sentry

It's new, it's monthly, and it's lasted for four issues, so Amiga Sentry is showing some staying power. But I don't know how they get by with using "Amiga" in the title, since Commodore won't let anyone else use it. The Sentry is all b&w with color covers, and is professionally done. The format is mostly reviews, with lots of nice, large b&w screen photos. Sept. looks at DigiPaint, Videoscape 3D, WordPerfect, and others; Oct. examines GO-64, Calligrapher, Forms In Flight, etc. I have yet to see a critical review in the Sentry. \$24/yr., 706 Old Marple Rd., Springfield PA 19064.

## COMPUTE!

Richard Mansfield's editorial in the Oct. issue of C! turned us on to Eric Drexler's book "Engines of Creation" (see the "Real World" column in this issue of INFO), and for that we're grateful. The rest of the Oct. and Nov. issues are so generic they put me to sleep.





AW is now monthly, and subs are \$24.97/yr. Nov. concentrates on business, with a "Business Buyers Guide" and several articles on what some folks are using their Amigas for. Dec. features AW's 665-product "Software Buyers Guide", plus a brief look at Amigas in the performing arts. AW's reviews have gotten downright believable (almost nasty!) in the last couple of issues. They're showing some promise.

## BYTE

Despite the fact that the Amiga forums are a hotbed of activity on Byte's own BIX network, they have totally dropped Amiga coverage in their magazine. They have caught "PS/2 and Mac"-itis. (They dropped the Atari ST, too.) No more "Best of BIX" for the Amiga, no reviews, no nothing. So we aren't even going to bother talking about them anymore, either.

## COMPUTER SHOPPER

Computer games are fine, but if you want a real challenge, try to find the Commodore and Amiga articles in an issue of Computer Shopper! They're holding at about 550 pages, with over a dozen good articles of C= interest in each issue. Two recent classics: Erv Bobo's defense of his wishy-washy reviews (p. 282, Oct.), and an excellent must-read article by Ted Drude and John J. Anderson on converting among Amiga, ST, Mac, and PC graphics formats (p. 13, Oct.). One recent slap in the face: In the Sept. issue Commodore 8-bit machines were relegated to the "Classic Computer" section of CS, along with the TI 99/4A, Tandy CoCo, and Timex/Sinclair!

## Miscellaneous Commodore Magazines

**GEO WORLD:** Sept. looks at the 1750 REU, includes some useful tips, and features 4 pages of very nice geoArt. Oct. includes tips on graphics file conversion and an article on producing bargraphs. Don't miss "Master Blaster"'s column on geoProgramming in each issue. 20 pages, \$20/yr., 38 Santa Ynez St., Santa Barbara CA 93103.

**COMAL TODAY:** #19 follows up the excellent Mandelbrot programs in #18 with a faster pattern generation routine, two 3D-type programs, and a look at the new COMAL Power Driver compiler for the C64, plus the announcement of a graphics package for C128 CP/M COMAL. LOTS of activity going on at the COMAL Users Group! Bimonthly, \$18.95/yr., 6041 Monona Dr., Madison WI 53716, (608) 222-4432.

**TWIN CITIES 128:** #17 includes a look at the C128D, reviews of CP/M Kit and BASIC 8.0, lots of C128 tips, and some keen observations by Editor-in-Chief Loren Lovhaug. As usual, must reading for serious C128 users. 24 pg., \$24/12 issues, PO Box 4625, Saint Paul MN 55104.

## Other Magazines

**FAMILY COMPUTING** is now called **FAMILY AND HOME OFFICE COMPUTING**. It's generic city; thumb thoroughly through an issue before you plunk down your cash.

**COMPUTER ENTERTAINER** has moved to 5916 Lemona Ave., Van Nuys CA 91411, (818) 761-1516. For news on all the latest games, it's hard to beat. 14 pg., \$35/yr. (monthly).

Arizona computer users have a new monthly newsletter: **The ARIZONA COMPUTING NEWS AND BUYERS GUIDE**. This outgrowth of the old MicroBIts is generic across machine boundaries, but the first issue (Sept.) looks pretty good. \$12.95/yr., 4645 N. 12th St., Ste 100, Phoenix AZ 85014. Good luck to Editor Mike Hallock and staff!

**CW Communications'** new bimonthly, **COMPUTERS IN SCIENCE**, provides some deep but interesting reading, and prints some nice color computer graphics, too. Even the ads are different.

If you're shopping for a printer, check out **COMPUTER BUYER'S GUIDE'S PRINTER BUYER'S GUIDE AND HANDBOOK #7**. It contains the specs on some 600 dot-matrix, daisy-wheel, and laser printers.

Hard-core video nuts on a budget might want to check out the Sept. and Oct. issues of **RADIO-ELECTRONICS**. There's a construction article for a Video Palette special effects box that is available in kit form for only \$85.

The Oct. **SCIENTIFIC AMERICAN** is their annual **COMPUTERS** issue, with all 11 articles devoted to computing topics. A fascinating update on the state of the art.

## Magazines On Disk

Many disk magazines have come and gone, but there are a few that have had some staying power.

**LOADSTAR** is monthly and generally gives you two C64/C128 disks for \$9.95. Much of the disk space is devoted to type-in programs from **COMMODORE** magazine, which are mostly in BASIC and easy to learn from. The disks are menu-driven and usually a good deal. They're up past issue #40, and a 12-month subscription (about 24 disks) is \$69.95, from: Box 30008, Shreveport LA 71130, (800) 831-2694

**JUMPDISK** is the oldest and most respected of the Amiga disk-based mags, with a reliable 1 1/2 year track record. What it lacks in flash it makes up for in sincerity and honesty. Good articles and original programs, with lots of learn-from BASIC and hardly any PD padding. It's \$3 for a "sampler", \$9.95 for a single issue, \$37 for 6, or \$66 for 12, and you can start with any back issue if you wish. 1493 Mt. View Ave., Chico CA 95926.

**AMNEWS** is the new Amiga kid on the block. This Canadian publication offers 3 disks and lots of good looks and flash for just \$9.95/issue. I've only seen issue #4, but the screens are pretty and the articles are entertaining. It looks like it's got potential. PO Box 1692, Champlain NY 12919, (514) 340-2320.



# INFO Reader Mail

## INFO MAILBOXES

Send comments, questions, and loose change to:

INFO Mail, Box 2300, Iowa City IA 52244

Or send EMail to our online mailboxes:

CompuServe	70215,1034
QuantumLink	INFO Mag
PeopleLink	INFO Mag
BIX	infomag
Delphi	INFO

INFO is no longer on PlayNet.

*Please do not call the INFO offices or send self-addressed stamped envelopes expecting a personal reply. We just don't have the staff to handle it. We wish we did. Right now we've got two choices: put out a magazine every two months, or answer all the mail and the phone calls. We hope you'll settle for the magazine. Thanks.*

*P.S. If you have a question about software or hardware, that's okay, but please try the manufacturer first!*

*more disasters like Black Monday. Again, I feel that we must stress the point that it is not the computers that are to blame; it is the managers who trust computers to make decisions for them. You can't take humans out of the loop. Humans are still necessary to provide the emotional and rational balance for data-crunching analysis, which is the only part of the decision-making process that computers do well. -Mark & Benn*

Mail From: Capt Turbo                      QuantumLink  
Date: Tuesday 22-Sep-87 23:16 edt  
Thanks for your fast reply online on the availability of INFO. You can consider me being a first class bug down at my local B. Dalton's. I won't stop 'til they carry your fantastic mag again. In my opinion it's the best Commodore Magazine around! Hope they get the message soon! Thanks again!  
Kevin J. Burns

*Kevin is one of several readers who found out that under our new distribution arrangement INFO had disappeared from some of the stores where they were used to seeing it. Of course, it also appeared in many places where it had not been before. While there are more INFOs out there than ever, some retailers may now have to get INFO from a different distributor than they did in the past. Every store in North America (and, indeed, around the world) can now get INFO if they want it. If your dealer doesn't carry INFO, ask him to contact his local wholesaler, who can get it directly from Select Magazines in New York City. If he would rather deal directly, tell him he can call Ms. Josh Foreman in Select's direct accounts department at (212) 696-7366. Thanks. -Mark & Benn*

Mail From: Michael99                      QuantumLink  
Date: Sunday 25-Oct-87 11:02 edt  
You did it again in the last issue. As usual you are right on target with your editorial! I read with great interest about the 'Computer God' and how business computers are being used to make major decisions, just a day after the Monday Massacre in the stock market. As things look now, computer trading or 'program trading' is being blamed for the downward spiral of the stock market. Huge blocks of stock are traded by computers in seconds and conditions were just right to start the domino effect where the computers just started selling everything. Then on Tuesday they suspended the computer trading in order for the market to correct itself. It's uncanny the way you warned of the dangers of the 'infallable computer' just before the market crashed. My congrats on your insight. Keep up the good work.  
Michael Oliver

Mail From: SkipK                              QuantumLink  
Date: Tuesday 15-Sep-87 21:24 edt  
OK you guys... I read *Neuromancer* (see the *Real World* column in #16), and now I'm hooked on computer-drug-corporate Cyberpunk nihilism! I'm reading *Count Zero* now (Gibson's second book), but what are the other books and authors in "this growing body of SF"?

*Well, there's a book titled *Schismatrix* by an author whose name I can't remember, and *Eon and Blood Music* by Greg Bear. Anyone know of others?  
Mark & Benn*

*In this case, we would just as soon have been wrong. As more and more important decisions are entrusted to silicon, I'm afraid we'll see even*

continued on page 34...

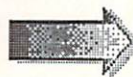

## COMMODORE NEWS

### THE 1541-2

Commodore's new 1541-2 disk drive should be shipping by the time you read this. It's a new cost-reduced design with a shorter 1571-styled case and remote "brick" power supply. The drive motor is still belt-drive, and the ROMs do *not*, as has been rumored elsewhere, include any speed enhancements. However, save-with-replace, block-read, and other bugs *have* been fixed. The new drive is 100% compatible with the old 1541, and has an even better software compatibility record than the rev B board 1541, according to project engineer Fred Bowen.

### 1581 BUGS

Some early release 1581 disk drives suffered from some annoying intermittent bugs. The trouble has been traced to problems in a soldered ground connection. Commodore will be fixing the problems under warranty. The problem has apparently been fixed, but there may still be some defective units on the shelves. Attempts to zero in on a range of affected serial numbers have been less than fruitful, so testing the individual drives remains the only way of identifying the defective units.

### CLIVE SMITH RESIGNS

Clive Smith, general manager of Commodore's Product Marketing and Development Group has resigned to pursue new opportunities in the computer field. He will be retained by Commodore as an outside consultant. Smith was heavily involved in various Amiga promotions, including the software bundling deal for the Amiga 500. Dr. Henri Rubin (who was brought into the Commodore U.S. operation from South Africa just last year) will move into Smith's position.

### FUZZY A2000 VIDEO

There have been some comments that the video output of early A2000s is not as good as that of the A1000. The problem seems to be an over-enthusiastic winding of the red, green, and blue video output wires through their RFI-ferrite beads. The solution is to reduce the number of windings to only one.



### TOY TAPPED FOR TOP JOB

Commodore has hired a new president and COO (that's Chief Operating Officer) for Commodore's U.S. division. A veteran of IBM, ITT, and Compaq, the man who has taken over Tom Rattigan's old job is Max Toy. While there are already a lot of backroom jokes about the name and how it ties in with Commodore's unfortunate image as a "toy computer" manufacturer, Toy's experience in marketing computers should pay off well for Commodore. He is said to be already cultivating his contacts at ComputerLand, BusinessLand, Inacomp, and other computer chains in the hopes of placing Commodore computers on the shelves in those stores. We wish him luck in his new job.

### NEW CBM PC CLONE

By the time you read this, Commodore should have FCC approval for and be shipping its new 3-speed IBM/PC clone with built-in ports and sleek, small-footprint styling. List price for a monochrome-card equipped unit will be \$699, \$899 for the color version. The margins are said to be good, so discount prices may be lower. Wasn't it *Atari* who promised to deliver something like this????

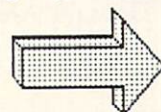

## BLANK ROMS SNAFU

A mixup at Commodore apparently resulted in the shipment of a number of blank 1571 upgrade ROMs for a period of about a week in early September. If you received replacement ROMs during that period and could not get them to work, contact Commodore Service. The odds are good your ROMs are blank!

## 1571 ROM INCOMPATIBILITIES

The new 1571 ROMs are incompatible with most of the copy programs on the market. *Fast Hack'em*, *SuperKit*, *Copy II*, and just about everything else that delivers superfast disk copying will *not* work with the new ROMs. Remember, the new ROMs are in the drive in the new C128D, too. In addition, the drive in the C128D replaces the Western Digital programmable controller chip with a PLA (Programmable Logic Array) chip that is not as flexible. It will still read all the standard CBM and CP/M disk formats, but will not be programmable to read other formats. I don't think this will create any problems with existing software, but it may get in the way if someone is working on a multi-format conversion program.

## COMMODORE VIDEO

If you haven't seen Commodore's new promotional video for the Amiga 500, rush down to your local Commodore dealer and check it out--literally. Dealers will allow customers to check out copies of the 20-minute video overnight. While the tape is essentially a 20-minute slick commercial for the A500, it does do a nice job of presenting the machine's capabilities, and showcases lots of third party (not just Commodore) products. Our only criticism: at first we were disappointed that there were no Amiga-generated sounds to speak of, until we read in the fine print as the final credits rolled by that the entire soundtrack was Amiga-and-MIDI produced, a subtlety that will escape many viewers. But the animation, graphics, business, and other demos should help sell a lot of A500s!

## COMMODORE TRIVIA!!!

Q: What Republican presidential candidate is a member of Commodore's board of directors?  
A: General Alexander Haig.

## COMPUTER SHOWS

The next **AmiExpo** show will be held at the Westin Bonaventure Hotel in Los Angeles from January 16-18. The show hours are 10 am to 5 pm each day. Call 800-32-AMIGA for information on exhibiting. (See Peggy Herrington's report on the NY AmiExpo elsewhere in this issue.)

The winter **Consumer Electronics Show** will run from January 7-10 at the Las Vegas Convention Center.

## LASER PRINTER BARGAINS

There's good news for those who have been waiting for the price of laser printers to drop. The new generation of laser printers is priced lower than the last; we've seen the new **HP LaserJet II** as low as \$1795 in mail-order ads. Better, the introduction of a new generation means that the *last* generation is now hitting the closeout market at really good prices. The best we've seen so far is Jade Computer's offering of the Centronics **PagePrinter 8** for \$995. This is an 8 ppm printer with a Sharp engine. A cartridge that supplies HP LaserJet Plus emulation and a Centronics parallel interface is only \$98 more, and other options are available including extra RAM and font cartridges. Other deals will be offering similar savings, I'm sure. (Jade's number is 800-421-5500).

## TEFLON DISKS

Kodak's Verbatim division recently unveiled a new diskette that is Teflon coated. They claim you can spill anything on one, wash it off, and recover the data. They'll cost a little more than normal diskettes (a box of 10 5.25" disks lists for \$23.80), but the peace of mind might be worth it, especially for important program backups and data disks.

## WORDPERFECT STUDENT DEAL

If you are a full-time college student or teacher who has been lusting after a copy of the very powerful but very expensive *WordPerfect* for the Amiga, lust no more! WordPerfect offers a substantial educational discount to full-time college students and faculty (would you believe *WordPerfect* for only \$99?). To get qualified, just contact them for an application form (send no money): School Software Program, WordPerfect Corp., 288 West Center St., Orem UT 84057, or call their Information Services Dept. at 801-225-5000.

## SALES AND PROFITS

Nobody knows for sure what impact the downturn in the stock market will have on the personal computer industry. Some people don't think it will hurt Commodore as much as it will IBM and Apple, since business traditionally suffers more in hard times than entertainment. In fact, entertainment was the only industry to thrive in the Great Depression of the 1930's. Of course, there were no computers back then, but it would seem to us that home computers could weather hard times as well as radio and film did in the 30's. Time will tell.

Meanwhile, in spite of the fact that they sold a million of the new PS/2 series computers in their first 7 months on the market, IBM's market share and total PC sales are down. It seems that corporate America is more interested in buying "industry-standard" MS/DOS clones from IBM's competitors than they are in buying into the unproven PS/2 line. Of course, PC sales account for only 15% of IBM's revenues.

On the other side of the fence, Apple's new Mac models are selling like the proverbial hotcakes. Apple sales for their fourth fiscal quarter ended in Sept. were up 54% over the same period last year. Apple won't say, but the *Wall Street Journal* is guessing that figure represents sales of about 175,000 Macs for the quarter. Ironically, sales of the lowly Apple II still accounted for about 40% of Apple's total dollar volume, which represents a great many more actual Apple II computers than Macintoshes when you take the price difference into account. Apple sales for the year hit \$2.66 billion.

Just for comparison, Commodore's fiscal 1987 sales were \$806.7 million, and Commodore insiders are projecting sales of a half million Amigas for the coming year.

## MS/DOS MEETS IFF

Inset Systems (203-794-0396), the publishers of *Inset*, a text and graphics integration program for the IBM/PC, have introduced an \$89 graphics conversion program for the PC called *HiJaak*. It allows MS/DOS programs to access graphics from many different incompatible MS/DOS sources as well as from the Macintosh and the Amiga. The program will also convert Mac or PC files to Amiga IFF format. Though there probably won't be much dancing in the streets over the prospect of using IBM/PC graphics on the Amiga, making Amiga graphics

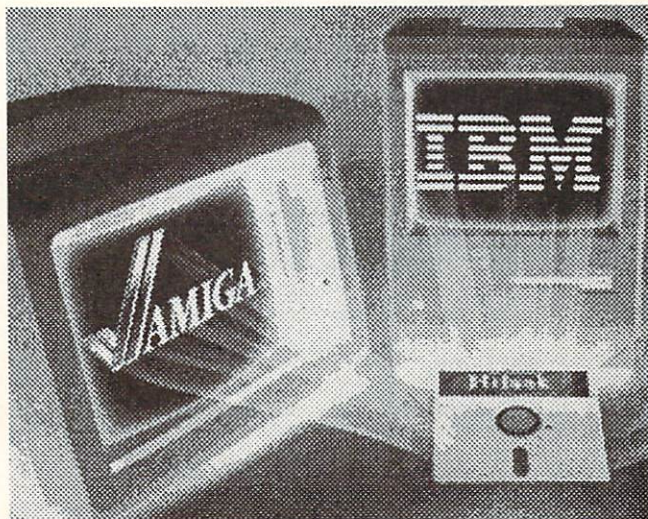

available to MS/DOS desktop publishing systems creates one more valuable argument for integrating Amigas into the business office. Thanks, Inset.

## FCC MAY MODIFY PROPOSAL

The FCC has been faced with solid opposition to its proposal to impose telephone access charges on online services. FCC Chairman Dennis R. Patrick testified before the Telecommunications and Finance Subcommittee that his office has received thousands of messages opposing the plan. He said more study is needed before the FCC makes its final ruling. This will most likely result in a reduction in the proposed access charges, a graduated transition period, or both. In any event, the originally proposed January 1st decision deadline is not attainable. The subcommittee also heard three hours of testimony from consumer groups that will be affected by the decision.

## FISHY DISKS

Fred Fish, regarded by most Amiga users as a real benefactor to all Amigadom for his collections of public domain software, was recently burned by a person or persons unknown. Someone took two commercial programs, *M* and *snap*, removed the copyright notices, and submitted them to Fred. He included them on Fish Disks #80 and #88, and the companies who own those products were understandably upset. Fred has asked all who own those disks to delete the offending files, and to provide information on who might have been responsible for this "prank". We hope that the Amiga community will provide the peer pressure necessary to keep something like this from happening again.



**DISCLAIMER:** The following are among the most entertaining rumors we've heard the past couple of months. They are presented for your entertainment and amusement only. Please do not base any important decisions on these rumors, as many will prove to be inaccurate or just plain false.

-> Commodore engineers are said to be close to a new *Denise chip* for the Amiga that will deliver 640x400 non-interlaced video. Initial reports say that all past Amigas should be able to upgrade to the new chips when they become available.

-> Meanwhile, the *Really Fat Agnes chip* (which will expand chip RAM accessibility to one meg, among other things) is very close to release. A500 and A2000 owners will be able to upgrade, but the new chips are incompatible with the A1000. It's not clear whether it's just a problem with the physical board layout, or whether it just plain won't be adaptable to the A1000 at all.

-> The unanticipated high demand for the *A2000 Bridge card* caught CBM's Marketing Dept. with their pants down. They thought they'd sell about one Bridge for every three A2000s sold; the actual demand has been almost one-for-one. Needless to say, Bridge cards are now hopelessly backordered.

-> The rumors of the death of *Basement Boys Software* (makers of *Fast Hack'em*) seem to be untrue. Mike Henry and company have, however, apparently tired of the hectic software business. Reports we get from readers say that BB never answers the phone anymore, and they are filling orders at a very leisurely pace. As to more updates for *Fast Hack'em*, it's starting to look less and less likely.

-> Likewise, with the phone disconnected at *StarPoint*, lots of folks have gotten worried about them, too. Though they are experiencing a

cash flow crunch precipitated by a long, costly court battle over *StarDOS*, *StarPoint* has survived. They are in the midst of moving, and are still filling orders by mail.

-> *HES*, however, seems to have disappeared from the face of the earth.

-> Things got nasty there for awhile between *EA* and *Origin Systems*. Origin left EA's affiliated labels program, and EA was thinking about bringing in the lawyers. Everything has settled down now, and Origin has signed a new distribution agreement with Broderbund.

-> It seems that *Commodore stock* held its value better than IBM or Apple in the recent "Black Monday" market crash...

-> Here's one for your "Computer Sniglets<sup>tm</sup>" dictionary: *HANDSCRIT*--The language produced when you type with your hands offset by one key on the keyboard.

-> Is it just us or is the *A500 mouse* really that inferior to the original Amiga mouse?

-> We hear that a top Commodore management official has decreed that the *C64 market* (including third party software development) will last only two more years, and Commodore is said to be making its future plans accordingly. They expect Christmas 1989 to be all Amiga.

-> Though *Atari ST sales* are said to remain strong in Europe, they appear to be dying on their feet in the U.S. With the response to the Mega STs so flat and developers bailing out of ST development, it looks like the *2600 Game System* will remain Atari's best-selling "computer".

-> Though early batches of *A500 power supplies* were prone to sudden death, Commodore has changed vendors and the new supplies seem to be holding up better. Like the C64, though, if you want to plug in many options you'll have to invest in a beefier third-party replacement power supply.

-> INFO is proud to have been a sponsor of the recent *Zeroth BADGE Killer Demo Contest*. Our congratulations to all the winners!

---

**GOOD DEAL:** Commodore's new **2002 monitor**, which replaces all of Commodore's older models. It features separated video, RGBI, and RGBA inputs and is compatible with the C64, C128, and all Amiga models. All for just a little more than the cost of the 1902A.

**GOOD DEAL:** The *TxED v1.31* text editor for the Amiga from MicroSmiths. Tiny (barely bigger than ED), fast, multitasking, with pull-down menus, and cut-and-paste. Just about perfect for everything, and only \$39.95. MicroSmiths, PO Box 561, Cambridge MA 02140, 617-354-1224



# BUTCHER & PIXMATE

by Mark R. Brown

## IFF PICTURE SURGERY

The problem with Amiga graphics is that they are so darned versatile! You have four different screen resolutions, plus overscan, plus virtual screens that can be larger than the display area. You can have anywhere from 2 to 4096 colors in any one picture, with regular bit-mapped, half-brite, and HAM modes of operation. And no matter which mode, resolution, or screen size your picture is, it's never the combination you need for just the right effect in your page layout, video animation, or killer demo program.

Even if it's in the right format, how about those stray off-color pixels in your digitized pictures? Or that image that would have been just perfect if it were only a little sharper? Then, too, there's the one that's just perfect...except you need four more colors to add some final touches, and there's no more room in the palette!

Fortunately, there are programmers and software companies out there who recognize the problems, and they've produced IFF-graphics manipulation tools that address all of these and more. Two of the first and best are *Butcher* v2.0 from *Eagle Tree Software*, and *Pixmate* from *Progressive Peripherals*.

## SIMILARITIES

The first and main feature of both of these programs is format conversion. Both will handle all the native screen resolutions of the Amiga, and will convert any picture format to any other. They'll also let you reduce or expand the number of colors in a picture's palette, or merge colors to produce effects, or create free space for adding more colors. They also both do edge detection and enhancement, let you play with complementary or pseudo coloring, convert a color picture to black & white, and create

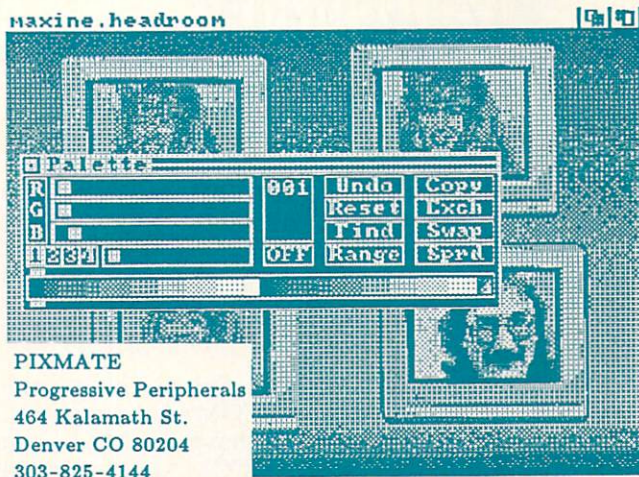
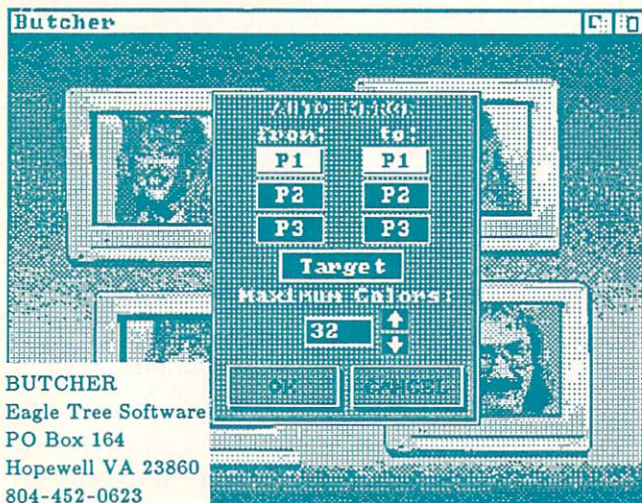

RGB or magenta-cyan-yellow color separations. They have quite a bit in common, but it seems to me that they were created with different philosophies in mind.

## DIFFERENCES

If I had to sum it all up in one short statement, I'd say that *Butcher* approaches image processing from the artist's point of view, but *PIXmate* treats the whole process like a science.

All of *Butcher's* tools are up front and easily accessible. Chopping, merging, and blending colors is a simple process, as is filtering odd pixels out of a digitized image. There is even a limited DRAW mode toolbox for subtle manual retouching of details. I like it for refining video artwork because it is fast, easy, and you get quick results that are pleasing to the eye.

*PIXmate*, on the other hand, is loaded with options. Its IMAGE PROCESS toolbox is overwhelming at first, but its power is incredible. It can do almost anything to an image that NASA can do, but you have to take the time to learn the ropes before you begin to comprehend what *PIXmate* is capable of. The user interface is easy enough to use, but you have to know what the buttons do and how different combinations of buttons affect the process. It's a little like flying a plane.

But no matter what you may think about the comparative complexity of these two programs, *PIXmate* does have one real uncontested edge over *Butcher*: its ability to operate on HAM images. Though *Butcher* will load and convert HAM pictures, its surgical capabilities are limited to standard 32-color-or-less IFF screens.

*Butcher* is more intuitive and easier to use; *PIXmate* is more powerful. They are both good products from good companies, and one or the other (or both!) is an absolute necessity for the serious Amiga artist.



# New Products

## C64

Electronic Arts has released **Instant Music** in a C64 version that is surprisingly good. It has only 3 voices (the Amiga version had 4), but the user interface is slick and the music is fantastic! And the C64 version is \$20 less than the Amiga version at \$29.95. Electronic Arts, 1820 Gateway Dr., San Mateo CA 94404.

The new **COMAL Power Driver** is a true compiler for disk-based COMAL programs. Now even those who don't have COMAL can run those fantastic COMAL-developed programs. Though the programs aren't made any faster, they do load and run from BASIC, and the Power Driver makes more memory available and adds some commands. \$29.95 +\$4 shpg. from: COMAL Users Group, 5501 Groveland Terrace, Madison WI 53716, (608) 222-4432.

Computer Mart has brought back one of the best BASIC programming tools ever written. **SYSRES Enhanced** adds tons of editing and debugging tools to BASIC. It's a classic, and we're glad to see it made available again. \$39.95. 2700 NE Andresen Rd., Vancouver WA 98661, (208) 695-1393.

**Survey-Master** brings market research techniques to the C64. With this program, you can conduct surveys and collate the data into professional-looking reports, complete with stats on reliability and confidence levels, et. al. \$29.95 from: Strategic Marketing Resources, PO Box 2183, Ellisville MO 63011, (314) 256-7814.

Micro R&D has a new 256K **Data Stuffer** printer buffer designed to plug into the serial buss of the C64 or C128. It offers a push-button reset and copy/pause for multiple copy printing. \$129.95. Call Max at: 3333 Wadsworth, A-104, Lakewood CO 80227, (303) 985-4077.

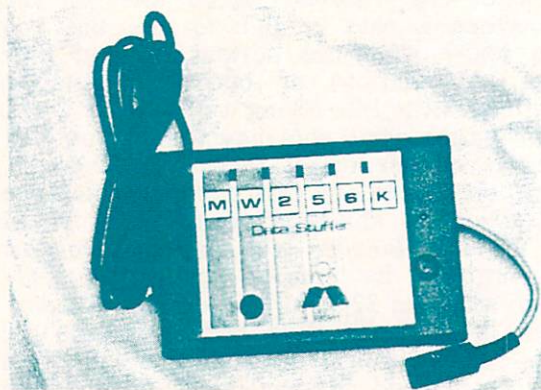

*Micro R&D's Data Stuffer.*

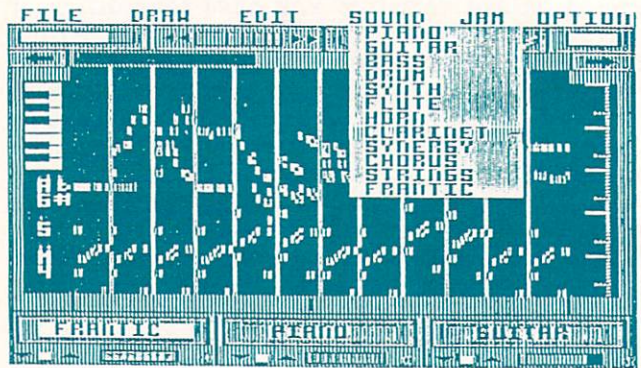

*C64 Instant Music from Electronic Arts.*

The **Commodore Diagnostician** is an 8.5" x 11" laminated plastic reference card from Australia. Its charts and tables help you diagnose what ails a dysfunctional C64/1541 system. \$6.95 + \$1 shpg. from Kasara Microsystems, 33 Murray Hill Dr., Spring Valley NY 10977, (800) 642-7634. They're supposed to be a good source of Commodore replacement chips, too.

One of our nominees for "Best Software Title of The Year" is a professional floor-covering layout and job costing applications program for the C64 called **Floor Essence**. \$79 from: Floor Covering Systems, PO Box 421339, Sacramento CA 95842, (916) 332-6336.

Brown Boxes has two new models of their **Quick Brown Box**. These battery-backed RAM cartridges let you store programs in a recoverable cartridge for immediate access. A technician friend of mine has a C64 with a BASIC program stored in a 16K Quick Brown Box serving as a stand-alone dedicated video test pattern generator, without the expense of a disk drive. Good, reliable stuff here. 16K=\$69, 32K=\$99, 64K=\$129, +\$3 shpg. 26 Concord Rd., Bedford MA 01730, (617) 275-0090.

## C128

The first kid on the block with a set of utilities for the C128 and 1581 disk drive is Free Spirit Software. Their **Super 81 Utilities** package lets you copy whole disks or files back and forth between 1541/1571 and 1581 format, backup 1581 disks, edit 1581 sectors, and even perform many 1581 CP/M functions. \$39.95 ppd. from: 538 S. Edgewood, La Grange IL 60525, (312) 352-7323.

Infocom's latest excursion into fantasyland is **Beyond ZORK**, the fourth in the most famous



interactive fiction series of all time. It has many innovative features (for Infocom), including windows, bar charts, *mapping* with zoom (!), programmable function keys, and *four-color* screens. Price structuring being what it is, C128 owners save \$5 over everyone else when they buy this game: \$44.95. (Not available for the C64, but the Amiga version is \$49.95). Infocom, 125 Cambridge Park Dr., Cambridge MA 02140, (617)-492-6000.

You can play the market with your C128 and **Strategist**, a shareware market analysis program. It lets you play different market strategies using actual market data. \$29.95 for a copy with manual direct from the author. Strategy Software, 909 Carol Lane, Fairbanks AK 99712.

**TREK 128** is a full-featured C128 version of the classic computer game *Star Trek*, with 80 column graphics & sound. \$19.95 + \$2 shpg. BYTE Power, Box 80546, San Diego CA 92138.

The **C128 Church Management System** is a two-module set of templates for **Superbase 128**. The \$149 *membership* module tracks and reports on all membership records. The \$75 *Contributions* module takes care of the financial side of things. It includes on-line help and phone support. **Superbase 128** required. From: C128 Church Systems, 3 Heritage Pl., Sewell NJ 08080, (609) 582-0889.

If you're interested in programming languages and utilities for the C128 in CP/M mode, contact **Workman & Associates**, 1925 E. Mountain St., Pasadena CA 91104, (818) 791-7979, and ask for a copy of their catalog. They list a Modula-2 compiler, ADA, and more.

## AMIGA

**Quarterback** is a new hard disk backup utility for the Amiga from those friendly, reliable folks at Central Coast. It is said to transfer 20 megs to floppies in 45 minutes. They also have an Amiga wordprocessor coming out soon: **Precisely**, \$80, with online help, floating footnotes, automatic index and table-of-contents, fast printer output, and the ability to import files from popular C64/C128 wordprocessors. Central Coast Software, 268 Bowie Dr., Los Osos CA 93492, (805) 528-4906

**Progressive Peripherals' Microlawyer** is a set of legal forms in wordprocessor-file format. There are over 100 common legal forms for printing on your printer, which hopefully will result in saving hundreds of dollars in attorney's fees. Included are: power-of-attorney, wills, prenuptial agreements, affidavits, leases, loan agreements, etc. (also available for IBM and

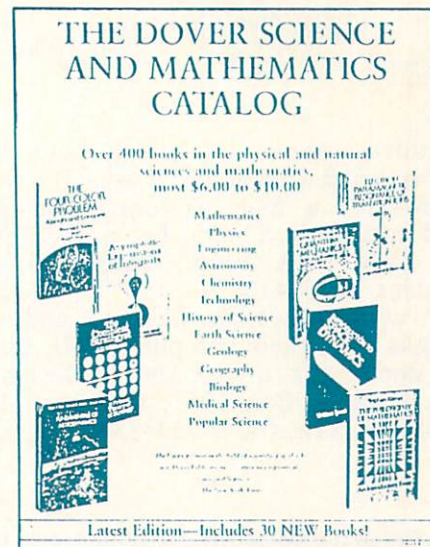

*The Dover Books Science & Math catalog.*

C64). \$59.95 from: 464 Kalamath St., Denver CO 80204, (303) 825-4144.

If you're a fan of EA's **Earl Weaver Baseball**, you might be interested in a set of two shareware disks from Patrick Mondout. They contain "All-Time Great Teams" (and stadiums) for match-up play. \$10.50 gets you both disks from: 1714 W. Bedford, Mesa AZ 85201.

There are lots of good PD "shell" programs for the CLI around. Most of them give you command-line history, in-line editing, definable function keys, and sometimes even resident commands. They really turn the CLI into a *usable* environment, and most people can get by just fine with one of the PD shells. But we use our Amigas all day every day, and we like the flexibility of the **Metacomco Shell**. It's highly compatible--after all, it comes from the folks who wrote **AmigaDOS** for Commodore. It's also versatile, with command-line history, user-definable resident commands, function keys, and aliases. I resent it when I have to use the CLI without the Metacomco shell. It sells for £50 in Great Britain, and the U.S. price seems to hover around \$65 or so.

C64/128-to-Amiga upgraders now have a way to take their Commodore 1670 modems with them. The **1670 Standalone RS232 Interface** is a box that makes the 1670 RS232 compatible so you can use it with the Amiga (or an IBM/PC, as far as that goes). All chips are socketed and it includes a small wall transformer that powers both the box and the modem. It features some nice touches like a modem reset switch, transmit/receive/carrier-detect indicator LEDs, and a 3-foot RS232C connecting cable. \$44.95 ppd. from: LRA Enterprises, 35615 Ave D, Yucaipa CA 92399.

Confused by the power of **DeluxePaint II**? The new, improved **DeluxeHelp** for **DPaint II** provides automatic on-line help screens and auto-

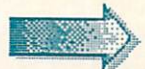

...continued from page 26

running tutorial demos of all of DPaint II's features. I've tried it out and I like the way it works a lot--it's a nice, friendly, and useful utility, and costs only \$34.95. From: RGB Video Creations, 2574 PGA Blvd., Suite 104, Palm Beach Gardens FL 33410.

Weave-It will let Amiga weaving enthusiasts create designs with their computer. \$70, but you can get a demo disk of 10 sample designs for \$10. Joyce I. Peck, Box 1051, Qualicum Beach BC Canada V0R 2T0, (604) 752-3364.

**MISC.**

Some of the best bargains in books are in the Dover Books catalogs. Their *Science and Mathematics* catalog lists 400 inexpensive trade paperbacks priced from \$5 to \$10, with titles like *Introduction to Artificial Intelligence* (512 pages, \$8.95), *Visual Illusions* (252 pages, 100 illustrations, \$4.95), and *Sir Isaac Newton's Opticks* (406 pages, \$7.95). Dover's *Art Books* catalog is similarly impressive, with dozens of inexpensive books full of public domain b&w clip-art (ready for digitizing). You can get their free *Complete Catalog of Books in All Fields* listing 3000 titles by writing: Dover Books, 31 E. 2nd St., Mineola NY 11501.

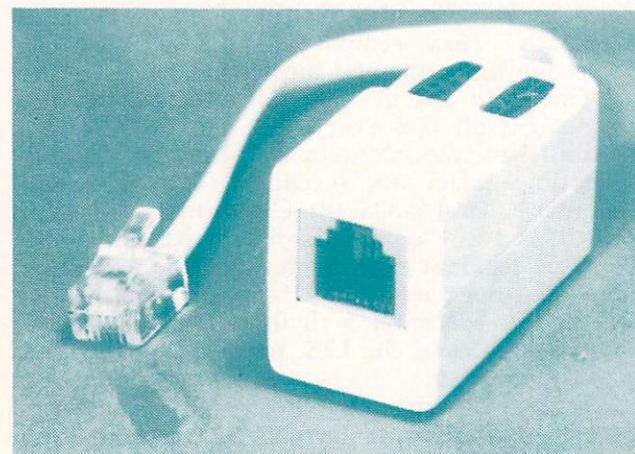

If your telecommunications are constantly being interrupted by people picking up extension phones, a Data Spec **Data Interrupt Eliminator** on each phone will disable them when your modem is in use. It also acts as a privacy device, keeping people on extensions from listening in to your conversations. You need one for each phone. \$9.95 for the model MP600 for standard phones, \$11.95 for the MP640 for wall-mount phones, Data Spec, 20120 Plummer St., Chatsworth CA 91311, (818) 993-1202.



Mail From: Fobozz QuantumLink  
 Date: Sunday 20-Sep-87 09:34 edt  
 How come I see many fantastic looking programs advertised in the British magazine, *Commodore* which are not available in the USA? In the July issue there is a very nice looking desktop publishing program called *Stop Press*. Do you have any information on this? Thanks.

*It takes a lot of time, money, diplomacy, paperwork, and flying back and forth across the Atlantic to import products from Europe. That and mile upon mile of red tape. We are starting to see many fine European imports in the States, but each one represents Herculean efforts on the part of the importer. The business of software imports is one of the topics that Jim Oldfield will be telling us all about in an upcoming installment of the Midnite Software Gazette.*

-Mark & Benn

Mail From: Steve Ham QuantumLink  
 Date: Saturday 26-Sep-87 15:06 edt  
 Whatever happened to the articles from Richard Immers that were supposed to be coming up a few issues ago? Thanks, Steve Cunningham

*Dr. Immers had some health problems that have kept him out of service for the last several months. He is now feeling much better and has started to work on reviewing some hardware-based 1541 fastloaders, which we hope to see in time for the next issue!*

-Mark & Benn

Date: 01-Oct-87 14:08 CDT CompuServe  
 From: Todd Oberly [73107,3150]  
 Subj: Commodore Buyout  
 I was talking with a salesman in Radio Shack today, and our conversation happened to turn towards Commodore. He casually mentioned that Atari bought them out about a year ago! I was speechless and rather bothered. I've only been reading INFO for the last 3 issues, and the tone of recent ones doesn't make me suspect a buyout (which sounds monopolistic and almost illegal). Is there any truth to this, and if so, is it being kept quiet or what?

*I was going to make a snide comment about how the typical Radio Shack salesman keeps up to date on happenings in the computer industry by reading the backs of cornflakes boxes, until I realized that if they could read cornflakes boxes most of them would be much better informed than they are now.*

-Mark & Benn



# Public Domain

## DEFINITIONS--

**PUBLIC DOMAIN:** Not copyrighted; available to all; free for the copying

**FREE-ACCESS:** Copyrighted but released for free public use; not to be resold for a profit.

**SHAREWARE:** Copyrighted but available for copying, with a donation requested from those who use the program.

## AMERICAN PEOPLELINK

by Robert Umfer

A Guided Tour with CBM\*BOB

In order to access Plink and get to its Commodore Club, you need an ID. Call (voice) 1-800-524-0100 from 9 AM to 5 PM Central time or (modem) 1-800-826-8855 anytime to register. You can choose a free one-hour demonstration account, or pay a one-time \$15 fee (which includes a free hour of on-line time) to join. By selecting Plink's special \$10-a-month frequent users plan, your 1200-baud hourly rate is lowered to \$3.71 an hour during non-prime time hours, making Plink the most inexpensive 1200 baud of all national services. No matter when you are on, you will always receive a 25% discount by selecting this special option.

## THE COMMODORE CLUB

Once you have reached People Link through your local Tymnet or Telenet node, the Commodore Club is just a few key presses away.\* Simply type `/GO 64` (or `/GO CBM`) from the main menu, and there you are. Type `Y` when asked if you wish to join the club. It costs nothing extra. If you are not into menus, then type `/ADV` at this point and get ready to look around the club.

The Club is divided into 14 public sections, each of which is devoted to a particular topic for a particular computer. For example, section

\* With few exceptions, what Bob has to say for the Commodore area also applies to PLink's Amiga area. Simply type `/GO AMIGA` to access the area, and use the same commands. The Amiga section's biggest conference is on Sunday nights at 9:00 pm CST on line 68.

5 is for telecommunications on the 64, while section 11 is for CP/M on the 128. By typing `/SEC` at the `CLUBS>` prompt, you can choose which section you wish to enter. If you already know that you want to enter section 3, type `/SEC 3`.

## MESSAGE BOARDS

Each section is divided into two areas: the **NOTICE** area, where members can post their comments and/or questions, and the **LIBRARY** area, where about 2500 public domain programs are available for downloading. Switching between the sections is very easy: `/NOT` or `/LIB` will take you from one to the other.

Once in the notice area, you can read (`/REA`) the notices, scan (`/SCA`) information about them (author, theme, etc.), or quick scan (`/QSC`) a listing of them. These commands have several options, each of which works with the three previous commands. `/REA ALL` is self-explanatory. (If this is your first time in the club, then open your buffer. The **NOTICE** section contains the 500 most-recent postings.) `/REA NEW` will show you those notices posted since your last time in the club. `/REA SIN DD/MM/YY` will display all notices posted since a particular date. `/REA BY ID` permits you to read notices written by a particular member's ID. `/REA NUM #` displays notice number #. `/REA TO ID` prints all notices written to a particular ID.

At the end of each notice you can reply to it (`/REP`), read other replies to it (`/RREP`), or read the original notice if this one was a reply (`/RTOP`). This command displays the main notice, followed by all of its replies up to the one that you just read. `/AGA` allows you to re-read the last notice.

If you wish to post your own notice, type `/POST`. You'll be asked for the theme of your posting, whose attention should be drawn to it (either one person or `ALL`), and the title of your notice. Next, you'll be asked to type (or you can `/Uload`) your letter. When you are finished, simply type `/SEND` on a line by itself, and your notice is ready for others to read.

## DOWNLOADING

Now that you have finished in the **NOTICE** area, type `/LIB` to enter the downloading library. All of the above **READ** commands work

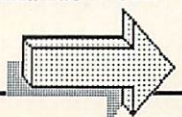



in the library, along with a few extra ones. If you know the TITLE or NAME of the program you wish to download to your disk, type /REA TITLE FILENAME or /REA NAME FILENAME. (TITLE is the name that you want to call it on your disk; NAME is a longer title, giving a little more information about the program.)

If you don't know either, but you know, for example, that you want to download a terminal program that uses Punter protocol, then type /REA KEY PUNTER. All programs which have the keyword PUNTER included in their description will be listed to the screen. At the end of the description, you can read it again (/AGA), read the next file (/NEXT or RETURN), or download it to your disk.

Two types of downloading are available: ASCII and Xmodem. (PLink supports 3 kinds of Xmodem: Checksum, CRC, and Windowed). An ASCII download does not check for any errors that might occur during the download (due to phone noise, etc.), and should be used for text (sequential) files only. Xmodem downloads one-half a disk block at a time, checking constantly to make sure the information is transferred correctly to your disk. It automatically resends any incorrect data. This protocol can be used with text files, and must be used with binary (PRG) files.

You can also download the description that you have just read by using either ASCII or Xmodem. This is a good idea if there is information in the description that you need to help run the program. To get this information using ASCII, type a 1; using Xmodem, type a 3. Press RETURN at the prompt and follow your terminal program's instructions for receiving a file. When you are ready to receive the actual program, type 2 for an ASCII download, and 4 for an Xmodem download. Again, press RETURN and follow your terminal program's instructions. You've just downloaded your first program!

## HELP AND CONFERENCES

If you need help while in the club, type /LIST to see if someone is there who can help you. (CBM\*LARRY and I, CBM\*BOB, spend a lot of time there, and are always available to help.) Send a message with the /MSG ID command, where ID is the name of the person you are trying to contact. Since most help is given in the conference area on line 1, you can get there by typing /CON;LIN 1 (don't forget the semi-colon).

Regular 64/128 conferences are held every

Tuesday evening at 9:30 Eastern on line 28 (/CON;LIN 28). A music conference is held every Saturday on line 36, and a special help conference is available every Monday. Plus/4 owners can attend their own conference on Sunday evenings at 10 Eastern (/CON;LIN 4).

## QUANTUMLINK

by Saul Cohen

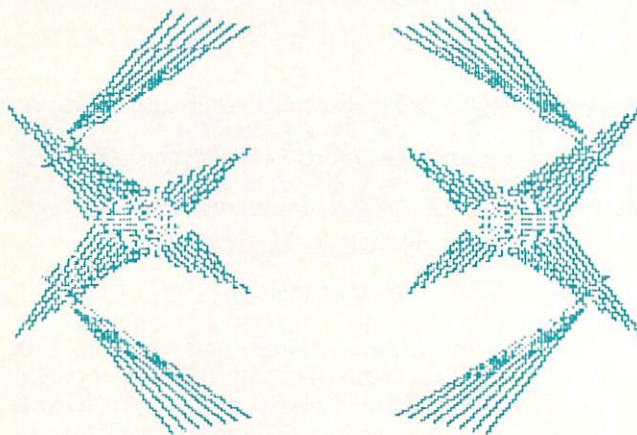

### SWINTH



FROM: Bill Byte

74 Blocks

D/L times 1200- 4:46 300: 16:43

This is an unbelievable music and light show. Watch as the program spins pleasing graphic displays and plays 10 songs. A variety of keys function to change the display as it is created. A menu of keys is presented at the beginning of the program. Another MUST have program.

### MUS.COMBO.LBR



FROM: MarkH39

Location: CSS/ Software Library/ Browse/ Music Room/ Sid Classical, Theme, Original/ Sidplayer Files/ Original and other

06/24/87 - 08/19/87

157 Blocks

D/L times 1200- 10:08 300: 35:29

Required Programs: SidPic V2.5 Or other Sidplayer program, Library 9.0

Special Instructions: mus.combo.lbr is a libaried

program. You need to use the Library 9.0 to dissolve the program back into working form. To start your music library, download this one file. When separated, it consists of 20 different songs including: Lady In Red, Higher Love, Brazilian, SomeLikeHot, YouGiveLove, Use/Lose It, CheersTheme, Top Gun, MacGyver, and 2001, to name a few.

## ATTACK FORCE



FROM: WVMIKE  
Location: CSS/ Software Library/ top 20  
40 Blocks  
D/L times 1200- 2:35 300: 9:02  
Joystick Port #2

Pilot your jet through a maze of obstacles as you position yourself to shoot down a series of towers. Check your scanner for invisible opponents which will appear at a moment's notice. Attack Force is an enjoyable game with ten different levels.

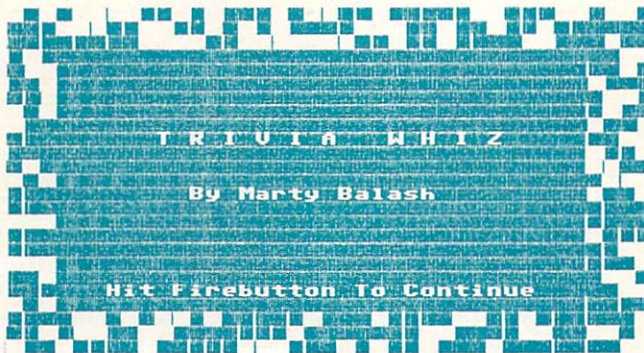

## TRIV.CON.SET.LBR



FROM: Marty5  
Location: CSS/ Software Library/ Browse/ Game Room/Arcade/Other  
03/24/87 - 05/10/87  
175 Blocks  
D/L times 1200- 11:17 300: 39:33  
Author: Balash  
Required Program: Library 9.0  
Recommend Program: triv.topics.lbr  
Special Instructions: Triv.con.set is libaried

program. You need to use the Library 9.0 to dissolve the program back into working form.

LOAD"GAME",8 (to start game)  
Joystick: Port #2

Use this program to play Trivia with friends. Two question files are provided with the game and you can also download the topics files found in the same section. Topics in the topic file include Geography, Show Biz, Leisure, History, Literature and Science. You can even design your own question files using the MAINTENENCE program provided.



### ABOUT THE AUTHOR:

Saul Cohen is an eighth grade science and computer teacher in Montgomery County, Pennsylvania. He also teaches a variety of computer courses to teachers. Saul's computer interests include wordprocessing, teaching applications, and of course telecommunications. You can reach Saul on QuantumLink via EMail to INFO SC.

## PEOPLELINK C64

by Robert Umfer

## XMODEM STRIPPER



Section 5 - File #4873

The program you just downloaded doesn't work? Then try Wayne Schmidt's padding stripper. Strip one file or the entire disk. An absolute necessity for anyone who downloads using Xmodem. The file is 32 disk blocks long.

## SPACE MOVIE



Section 14 - File #3548 Load this into your 64 and show your friends the wonderful things your computer can do with sound and graphics. They'll be amazed at what they see and hear. SPACE MOVIE is a classic graphics demonstration. The file is 43 disk blocks long.

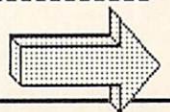



## SIDPIC V3.4



Section 6 - File #5946

Kermit Woodall has updraded his SIDPIC, an excellent program which makes listening to SID music a visual as well as an aural pleasure. The grand staff is now a full keyboard with colored keys playing the real notes. V3.4 plays those extra-large .MUS files, and displays Koalapad, Doodle, or black and white HiRes pictures. Plink has over 1,000 SID files in section 6, so you'll surely find plenty to download. The file is 76 disk blocks long, and is in a self-dissolving ARC format.

## A SAMPLER OF SID SONGS

PRELUDEINE.MUS; Section 6 - File #6988; SID harpsichord version of the *Preamble to Bach's Sixth Violin Sonata*. SID writing at its best. 32 blocks.

SWAN.PIL; Section 6 - File #6276; Camille Saint-Saens' *Le Cygne* (The Swan), written for the 64 by Marvin Jones. The PIC file included is as soothing as the music.

ELVIS.SDA; Section 6 - File #5117; Jerry Roth (DR J) has put together about 20 Elvis songs with a fantastic graphic to look at. This is certainly one of his finest works. 49 blocks, self-dissolving ARC.

## PEOPLELINK C128

by Robert Umfer

## PSLABEL128.SDA



Section 12 - File #6433

Brian Heyboer's PSLABEL128 will print out one-inch mailing labels from any Epson-compatible printer along with a three-block Print Shop (non-CBM-type) graphic on the left side. It prints up to 6 lines for the address in any of Epson's fonts. If you don't have Print Shop, Plink has several hundred graphics, including a fancy alphabet, in section #7. PSLABEL128 works in 40 or 80 columns. It's 18 disk blocks long, and is a self-dissolving ARC file.

REMEMBER: You don't have to be on QuantumLink or PeopleLink to get these programs--many are available from local users groups.

You can get information about signing up for these network services by calling:

QUANTUMLINK: 703-883-0788

AMERICAN PEOPLELINK: 312-870-5200

## BREAKUP128.COMP



Section 12 - File #4634

I wrote this file when my word processor wouldn't load a large sequential file. BREAKUP reads that file and divides it into smaller disk files that will fit. The new filenames append -1, -2, etc., to the original name. It reads from and writes to any drive. A 64 and Plus/4 version are also available in the library. It is compiled for speed. The file is 55 disk blocks long. (Be careful of Xmodem padding!)

## WHEEL OF FORTUNE



Section 12 - File #4901

Lee Semel's version of this game show is excellent, including the graphics. Up to 3 players can play, and a short file is included explaining how you can create your own puzzles. The only drawback is that each puzzle is its own one-block file, so you are limited to 144 puzzles on a 5.25 disk (or 296 on the 1581). The WHEEL spins in 40-columns only. It's 111 blocks long, and is a self-dissolving ARC file.



### ABOUT THE AUTHOR:

Robert Umfer, as CBM\*BOB, shares the Sysop duties with CBM\*LARRY in the Commodore Club section of American PeopleLink. He has a B.A. in French and an M.A. in computer science. His 'day job' is teaching high school French and Spanish.

## PEOPLELINK AMIGA

by Jim Burnes

### CONMAN, v1.0



by Bill Hawes

Section 11 - File # 7992

Also available on GENIE and on Fish Disk #80.

*Conman's* one-two punch of command line editing and CLI command history management make it one of the most useful utilities in existence for the serious Amiga user. It makes using the CLI more manageable. *Conman* keeps a command-line history, which is a list of all of the commands you've typed in since you started the CLI. By using the up and down arrow keys, you can step backward and forward through your previous commands. When you see the one you wish to fix, just use the left and right cursor keys to move edit your errors using the delete and backspace keys. The control-S and Q keys now stop and restart console output. Function keys F1 and F2 now shrink and expand the CLI window; a press of the F9 key will move a screen in the background to the front and F10 will move a window in back to the front.

---

### LARN



Section 10 - File # 6124

ported to the Amiga by John Toebbes III of the Software Distillery.

Also available on Fish Disk #63

Your daughter is dying of a rare disease and the only cure lies deep in the dungeons of Larn. Sounds like a hook to D&D game, right? Sure is! This addictive public domain game is obviously a derivative of *HACK*. The Amiga version of Larn (and *HACK*) are done with character graphics, as were the UNIX originals. Larn is organized as a top-down view of the dungeon you're exploring. Making your way down into it, you will use magic and your superb fighting skills to defeat monsters, demons, dragons and other nasties. It's probably a good idea to save your game once in a while because no one lives forever. This game is enough fun to keep you battling the dragons till dawn!

Amiga Larn 1.0.00 Copyright 1987 Edward Bonnette The Software Distillery

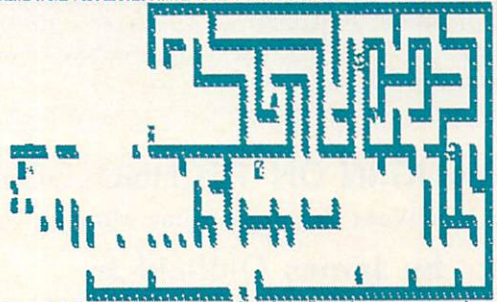

Protect 3

Spells: 0(1) AC: 5 WC: 3 Level 1 Exp: 4 novice explorer  
HP: 18(18) STR:10 INT:12 WIS:12 COM:12 DEX:12 CMA:13 LV: 1 Gold: 368  
The jackal missed  
The stuff you are carrying presently weighs 19 pounds  
You hit the jackal  
The jackal died!  
The bat hit you

---

### uSHOW



by Darren Massena

Section 5 - File # 6246

What was it P.T. Barnum called his productions... "THE GREATEST SHOW ON EARTH!"? Well, P.T. had nothing on this little gem! *uSHOW* (that's pronounced "microSHOW") displays IFF format pictures of any kind (including HAM) and does it (get this!) in 975 bytes. This compares with an average show utility program size of about 11k bytes. Put this one in your c: directory--it's the picture display command that AmigaDOS forgot.

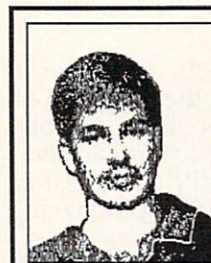

#### ABOUT THE AUTHOR:

Jim Burnes holds a bachelor's degree in computer science from the University of Missouri, Rolla. He is a professional programmer and his hobbies include scuba diving, programming, and cycling.



# Midnite Software Gazette

-----  
The opinions expressed in this column are those of the author, and do not necessarily represent those of INFO Publications, Inc., our staff, our lawyers, or any other living human being.  
-----

## CASHING IN ON TECHNOLOGY:

(or: So You Want To Make Some Money, Eh?!)

by James Oldfield Jr.

## CHANGING TIMES

The personal computer market has matured over the last ten years. (Actually, 'personal' computers have only been around that long!) From the early Dark Ages of the late-night hackers selling homebrew products, to the corporate sophistication of the software publishing giants, we've come a long way in what we consumers expect and demand for our software buying dollar.

It's a better system overall, but it's also sad in a way. Ten years ago you could 'simply' write a program, advertise it, and fill the orders that came in. If you were like the majority, you just used the equipment you programmed with to reproduce it. It was simple and straightforward, but quality was sometimes an issue. Today we have learned to take for granted the quality of products being brought to the software market.

Though it's possible for a one or two person operation to be a profit-making software company, like it or not the 'big guys' rule the roost. Why then, should anyone try to penetrate the volatile computer software market? Because as big as *Electronic Arts*, *Activision*, and *Epyx* are, they don't have a monopoly on good salable ideas and products.

## WHAT IT TAKES

I've worked five of these last ten years for a computer company, and I've had the pleasure of wearing many different hats. I've been (to one degree or another) a service-repairman, programmer (though not that good!), beta tester, technical advisor, retail salesman, purchasing agent, advertising manager, store manager, software developer, production manager, marketing and advertising manager, graphic designer, writer, publisher, distributor, and customer support manager, and held hosts of odd jobs in between. All of the 'professionals' I know in the personal computer business have had to wear those hats to some degree as well.

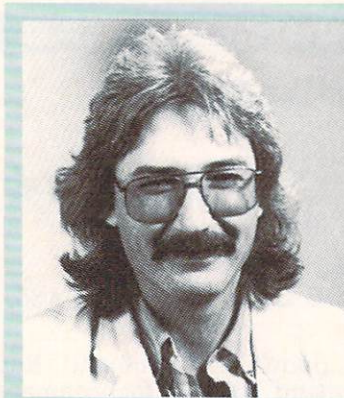

James Oldfield Jr. is Vice-President of Micro-Pace Computers, Inc., Director of The Midnight Press, a consultant for Constellation Software, and a Commodore Guru, first class. You can reach him on QuantumLink as Midnite.

So how does an ordinary person become a professional computerist? How does a person go beyond the 'user' status in this huge computer market? This article is intended to help you find a way into this profession. No, you don't have to spend half your life learning to program, or hold a degree in any of those disciplines I listed above. It takes hard work, determination, and a few pointers from those who got started in this business a little ahead of you.

Everything begins with an idea. What I want to address here is the time between getting your idea and producing a finished product that you can sell. Hopefully, I can give you some ideas to help you along. I've broken the process down into a few simple steps to fit things into the confines of this article. The first is Product Design.

## THE BASICS

Let's start with the basics: You have an idea for a super-duper whiz-bang game (or utility, or database, or educational program...). You've checked INFO's **Product RoundUp** and you're convinced that there's nothing on the market quite like it. Are you a programmer? If not, you're going to have to hire someone to do the programming for you. Most aren't cheap and all consider themselves underpaid. (We'll get into the subject of costing and producing a salable product later.)

If you're programming the game yourself, forget BASIC. Today it's machine language programming for speed and compactness of code. If the game's for the C64, (which has the biggest market potential) 64K will look awfully small in contrast to the professional development machines used by larger companies.

Most high school computer classes teach you to use flow charts for the programs you intend to write. Few programmers I've worked with use them. Many use "story-line" program design for



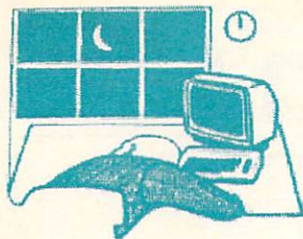

graphic layouts, story boxes, and the program's overall execution; the method is similar to a film director creating a storyboard for a movie production.

After the initial decisions about the program's intended function, you break the program down into smaller units and work towards a finished program. Though it's still possible for a single programmer to create an entire program, in this day of programmer "specialists", there are many people who excel in different areas of game design such as graphics, music, user interfaces, and the like.

Productivity software is different in the sense that there are fewer abstract diversions such as keeping high scores, sprite and BOB collisions, multiple player interactions, 'thinking' computer opponents, etc. Don't get me wrong--I don't think games are more important than accounting and other 'serious' business programs. It's just that a lot of people have a tendency to equate 'seriousness' with the price tag on the product. Games are no less serious to the programmer and/or producer. Business and game software both make money, just on a different scale of profit margins.

When more than one person is involved with writing the program, meetings are held so that the others know what's going on. The artists need to know what type of title screen you need and the programmers need to know what is expected of them. When all involved are sure of their assignments, the development time is shortened.

## AFTER IT'S "DONE"

After the program has been written there's much more work to be done before it goes into the packaging.

One consideration is the documentation. You need instructions on how to run the program. If it's a game, that might be as simple as a blurb on the box that says "Plug in a joystick (*which port?*), Load (*How do you do that?*), and Go!" But if it's a productivity program, you could need a thick manual. Don't overlook spelling and punctuation within the documentation and in the program itself. (How many adventure games have you played that had so many misspellings that it detracted from the pleasure of playing them?) And don't forget the table of contents, the index, and the quick reference card!

Beta testing, by in-house people (such as spouses or your children), friends, or users who use similar software in real-world situations, can tell you whether the program is functioning as it should be, or if there are important features you've forgotten to put in. From experience, I can tell you that you should never consider your own playtesting as the final test. You'll never be able to duplicate the weird and sometimes unprecedented situations that some users will run into. Hard as you try, you can't foresee *all* the variations. Corrections and modifications can and must be made based on this beta testing.

It's very important to decide who you will trust to test your program. Keeping it in-house keeps it in front of you, so to speak. You don't want to entrust your program to someone who will 'accidentally' copy an early (or final) version for one of *their* friends to play. You should consider having your testers sign a non-disclosure agreement to protect yourself as well as others involved in the playtesting.

Speaking of protection, are you going to protect your product from being copied for "archival back-up"? Many a user turned professional programmer changes his attitude about piracy when it's money coming out of his pockets. There are quite a few protection schemes available for a price, either for a per piece cost or a straight one-time cost (all of which claim they can't be copied). Mass duplicating companies provide a one-stop service by doing the duplicating of your disks and protecting them for you at the same time. Although this is convenient, the price tag is higher than the alternative, which is to use the expertise of an old "hacker" turned legitimate.

## BOXED IN

Ok, your great idea has become a fully functioning whiz-bang game. What are you going to put it in? Obviously you don't want to package it in a brown paper bag, unless of course it's shaped like a bottle and you *want* it to look that way! It's time to put on the marketing/product design hat.

For a product to sell today it *must* be packaged correctly. It's a sad truth that many great programs failed simply because no one took the time to design an appropriate package to put it in. You don't want a picture of a spreadsheet on your box containing 'Invaders'. Package design should reflect your program's purpose and it's projected price range, and it *must* bring attention to your product on a dealer's shelf. There's a lot of competition out there.

*Next issue: Packaging pointers and how to get that program to the dealer.*



# USER GROUP UPDATE

by Len Lindsay

## NEED INFORMATION?

It's nice to be back sharing information with other Commodore computer users. Kind of like the good old days when I edited and published the *PET Gazette* (now called *Compute!*). Old days? Ancient is more like it...that was 10 years ago!

Many people missed the *PET Gazette* after its transformation into a slick magazine. So much so that the *Midnite Gazette* was started (notice the carryover of "Gazette" in the title). Just recently its Editor, Jim Oldfield, joined up with *INFO*. Now I'm here too. Is it Media Magnetism?

I've admired *INFO* since its first issue. I wondered how they could put out such a top quality magazine with so few people (no huge staff like the big guys). I was so curious in fact, that I drove out to their "International Headquarters" in Iowa, hoping to find out what some of their production secrets were (I also publish *COMAL Today*, an 80 page magazine, with just two assistants). Instead, I became a new columnist for *INFO*.

The focus of this column is local User Group recognition. Each local User Group works hard to help its members. I think it is time that their efforts are recognized. I will try to pass along helpful information that I find in the many User Group newsletters that I read. I also will try to provide some tips for the User Groups themselves, and even announce special upcoming User Group sponsored events. Groups are invited to send me any information they wish to share with other groups and their users. I get hundreds of newsletters now. And yes, I do read them. I even keep them in file cabinets! I am interested in reading your group's newsletter too. Just add me to your mailing list:

Len Lindsay  
PO Box 6055  
Madison, WI 53716-0055

You also can contact me on QLink. My ID is: **Captain C.**

As I pass along information from the groups, I will also include the address they use as the return address on their newsletter, along with a copy of their logo or newsletter banner. If you are in their area, drop them a line. You should find your local group to be a good source of information.



CCCC  
TUCSON, ARIZONA

CATALINA COMMODORE COMPUTER CLUB, INC.

User Groups now have an opportunity to provide a full featured word processor to their members for an incredibly low price. **Write Stuff** is available for user group distribution. The word processor with 50 page manual, 12 page quick reference booklet, and laminated keyboard overlay can be provided to your members for about \$10 per copy. This includes a profit for your club as well as for its author, according to Catalina Commodore Computer Club! Contact Busy Bee Software for more details. A demo disk may be available now as well.

Busy Bee Software  
PO Box 4655  
Santa Barbara, CA 93140-4655

Catalina Commodore Computer Club  
PO Box 32548  
Tucson, AZ 85751-2548

C  
U  
S  
L

## KEYWORDS

Journal of the Commodore User Group of Saint Louis, Inc.

GEOS fans take note: Commodore User Group of Saint Louis reports that there are two GEOS Bulletin Boards. One, called GEOS Central, operates 24 hours a day at 300/1200 baud: 1-619-280-2696. The other is run by Mystic Jim (a contributor to *Geoworld*): 1-303-321-8954

Commodore User Group of Saint Louis  
PO Box 28424  
Creve Coeur, MO 63146-0984

## HOW TO FIND YOUR LOCAL USER GROUP

If the idea of joining a local User Group is appealing, you still have to locate the group. Most don't advertise and are not in the phone book. But you can find them if you try.

1) *Computer Shopper* is a BIG publication which might be available at your local bookstore. It prints a comprehensive listing of local groups in each issue.

2) You could call Commodore and ask for your local User Group contact. They should have someone's name and phone number if the group registered with Commodore. Their phone number is: (215) 431-9100.

3) If you are a QLink subscriber, check the online User Group listing area. Here is how to get to that section:

- a) go to CIN (Commodore Information Network)
- b) choose USER GROUP SUPPORT CENTER
- c) choose USER GROUP LEADER EXCHANGE
- d) choose DIRECTORY OF USER GROUPS ON QLINK

Once you are there, pick the proper section and search for a message entry for your area. NOTICE TO USER GROUP LEADERS: Please make sure your group is entered in this section on QLink. It will help users in your area find you. (see end of article for QLink address)

4) Check with your local library. They may have a list of local User Groups, or maybe the group holds its meetings in your library meeting room.

5) Check with the computer studies department of your local High School or College. They might know about the User Groups in your city. Perhaps the Group even holds its meetings in the school (one of our local groups uses a High School for its meetings).

6) Check with your local Commodore retail outlets. They may know where the Group has its meetings. If you have a modem, they also might know some local Bulletin Board Systems (BBSs) that you can call. Once on a BBS, you can ask the SysOp or post a question on the message board. Many Groups actually have their own BBS, so you may have found them already.

7) If you have a modem, you also might join QLink or another online service. Once on the system, post a message that you are looking for the local Group in your area.

8) Put a small ad in your local newspaper classified section, under the computers heading. Ask someone from the local Commodore Users Group to call you and that you are interested in joining the group. The cost should be minimal.

## TIPS TO THE GROUPS

And now, some tips for the User Groups themselves.

Your group should consider renting a Post Office box if you don't already do so. The cost is minimal, and varies by the size. Use the PO Box as your main address. This gives you a permanent address regardless of who is the president or newsletter editor. Stop by your local

Post Office and fill out the simple form they provide you.

You will find that different members will be good in various computing areas, such as using a specific wordprocessor, database, or programming language. Many groups are now organizing a People Help List. Members volunteer to help other members in the specific area that they excel in. Their names and phone numbers are listed in the newsletter. If your group does this, consider prefixing the list with something like this (taken from Catalina Commodore Computer Club):

*"The following people have volunteered to be available to help you in various areas of computing. As you can see, new names have been added, and this list will be updated monthly. Please consider adding your name to the list in your favorite area of expertise. We would like to have a name for all major programs, so if you see a void and would like your name added please contact us. Please consider members' private time ... ABSOLUTELY no calls after 9pm. Thanks to all volunteers, present and future."*

If you need more material for your group's newsletter (a common dilemma), you may find QLink useful. About 400 groups now participate in the special User Group Leaders area on QLink. There are article text files that you can download, as well as online conferences about common User Group problems, and even a message board allowing groups to share information and hot tips! If your group would like to join in, just drop a line (EMail) to QLink ID: **Group Host**.

QLink  
8620 Westwood Center Drive  
Vienna, VA 22108  
1-800-392-8200

*...NEXT TIME: maps and calendars!*



### ABOUT THE AUTHOR:

Len Lindsay is one of the true pioneers of Commodore computing, and we're happy to be welcoming him to the pages of INFO. He was the publisher of the PET Gazette (the first newsletter for Commodore users) which later became COMPUTE! Magazine. He is also the founder and the head guru of the COMAL users Group. His "day job" is operating the computer system for the state of Wisconsin. You can reach him on QLink as CAPTAIN C.

# PART THREE geos UPDATE

by Don Romero

*...this month we continue with the third installment of the Saga of GEOS as related by INFO Contributing Editor Don Romero.*

## SCAVENGING

It's a slow time for reviewing "official" GEOS products just now. A plethora of new (and not so new) titles are on the verge of being released by Berkeley Softworks: **GeoPublish**, **GeoProgrammer**, **GeoCalc**, **GeoFont**, **GeoFile** (again) and **Writer's Workshop 128**. But they are not here yet and my long range telepathy is, unfortunately, out of whack. (Parts had to be special ordered from the factory and you all know how painful that can be!)

So our Fearless Editor pointed me toward the various efforts being made with and about GEOS by persons other than those in the employment of Berkeley SoftWorks. And actually, there was quite a bit to see: a healthy sign perhaps for those out there who are wondering about or skeptical of GEOS' staying power. The non-BSW GEOS support ranges from the blatantly to the negligibly commercial on through to a mix of typical and superior public domain programs, graphic files and such. But rumors about other major developers like Timeworks and Accolade offering GEOS applications and games of their own seem to be just that: rumors.

We'll start with a couple of GEOS publications and a note about Mystic Jim's shareware group; then on to the telecommunication networks, which is where lots of nice things are taking place; from there, it's the fun and games side of things -- although I *have* heard it said that creating documents and illustrating reports is actually *fun* now that GEOS is around. (Shall we write them off as incurable workaholics?)

## PUBLICATIONS

An entropic void of Questions ensues every time a new computer, operating system, programming language, hardware accessory or new genre of software becomes available - to say nothing of upgrades for all of the above. GEOS, as the 'official operating system' for the Commodore 64 certainly qualifies as an appropriate target for some of this balmful publishing effort.

And it has garnished its share: at least four books, and the rationale for revisions to several others; regular columns in many of the major

Commodore magazines (including this infinite series--which my Editor assures me is *not* a GEOS column); and currently, two monthly GEOS spawned and dedicated shadetree journals.

## MISTER G NEWSLETTER

I came across a sample of the Mister G's GEOS Users Newsletter on Q-Link one night. The 15 page GeoWrite file (complete with modest and tasteful graphics) was in fact the very first Mister G issue (dated March 1987) minus some of the larger graphic files that were part of the original issue. The sample issue contained many useful tips about making backup disks, using a spreadsheet to keep track of files on GEOS disks (creative, that) and using fonts, including a "Font of the Month" piece. According to the sample, the typical Mister G newsletter runs four pages long and is full of useful tips and information aimed toward the average GEOS user (i.e., the non-programmer). A six-month subscription to the Mister G newsletter (six issues) costs \$6, and a full year (12 issues) runs \$10.

## GGEOWORLD

I've always wanted a Multilith 2650 offset printing press (though I'd settle for a LaserJet Plus.) I dunno. Maybe it's that little touch of the Infinite, of being able to create unlimited copies of the same image. I know that there are a lot of people who are glad Roger Ledbetter has one. Roger is the publisher of GGEOWORLD.

When I E-mailed 'GGEOWORLD' to send me some copies, Roger replied that he hoped I'd find some good things to say about his and editor Skip Goetzinger's efforts. No problems there, Roger.

Physically, GGEOWORLD has more of the look and size of some of the better user group newsletters, averaging about 20 pages of laserprinted durable non-glossy stock. But the contents are the thing.

GGEOWORLD was born of ideas that came together on Q-Link and the origins show: it's like seeing the GEOS Arena down on paper. The gang's all there. 'GEOS Rob' Siegal has a monthly column as the front man for BSW. Mystic Jim regularly relays the doings with his expanding GEOS shareware group. Master Blaster tutors the pilgrims on programming under GEOS in terms that ML non-experts like

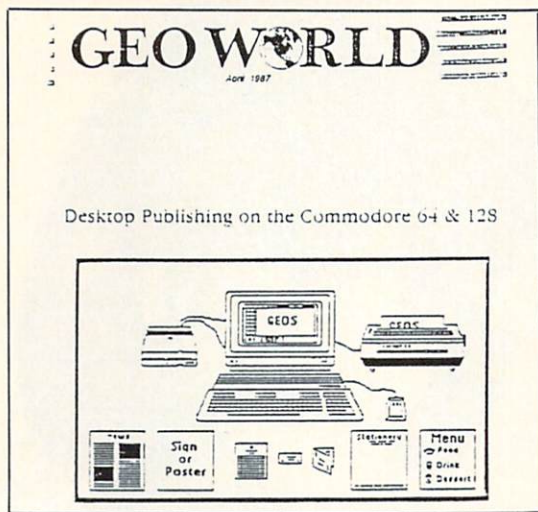

myself can readily understand. And there is more: a regular GEOS graphics gallery, GEOS classifieds, and even the occasional type-in GEOS program.

If you'd like a taste of what transpires GEOS-wise on Q-Link without going online, try the introductory offer of six monthly issues for \$12. A tad steep maybe, but over six months the benefits should compare favorably to what you'd get out of the dollar-equivalent three hours of plus time on Quantum Link. (Especially at 300 baud!) And I expect the magazine will grow along with the expanding readership.

If you are already designing a shrine for your GEOS SYSTEM backup disk with lots of candles and graven GeoPaint images, you'll probably want the \$20 full year subscription.

## MYSTIC JIM

There seem to be a lot of "Jim"s in the Commodore directory. This one - MYSTIC Jim - is to GEOS what the Big Jim is to Commodore computers in general: a programmer, a teacher, an organizer, and a pretty nice fellow.

I had wanted to chat with Jim about his wide-ranging GEOS shareware projects, including the Mystic Jim BBS, for this installment. It didn't happen but by all means stay tuned to this channel...

I can tell you a little about *Mystic Jim's GEOS Shareware Group*. For \$40, each member gets a subscription to GEO WORLD, access to the Mystic Jim BBS (Denver), program updates upon request from the growing shareware library being generated by Mystic Jim himself (*Bootstrap, Imagecon*) "Cosmac Art" Dahn III (*GeoFont, Pattern Editor, GeoDump*), Bill "Master Blaster" Coleman (*WatchSet*), Ben Taylor

(*Convert 1.4, GeoLinker*), Jeff Fox (*Quick Datasets*) and several others.

If you had belonged to the GEOS Shareware Group, you could have been using *GeoMonitor, GeoEditor, GeoHeader* and more while you were waiting for BSW to release *GeoProgrammer*. Or as an artist you could be using *GeoMetry* to supplement *geoPaint* with arc, ellipse, sizing and proportional printing functions, or the *Pattern Editor* to redesign the standard patterns that come with GEOS; or a variety of graphic file format conversion programs. The group disks also offer a slew of fonts, help files and more utilities and programs.

To join the Mystic Jim GEOS Shareware Group, E-mail Mystic Jim on QLink, or just send along your check or money order.

## GEOS ONLINE SUPPORT

It was natural for Berkeley Softworks to use QuantumLink for their main instrument of customer support. GEOS is the official operating system for the Commodore 64, and QLink is the official Commodore 64/128 Information Network. The flip side of every original GEOS boot disk has a copy of QLink's terminal software on the back. And the QLink docs are part of the GEOS manual.

On Q-Link you can discuss GeoProblems with GEOS Steve and an avid pack of non-official GeoHelpers; download the newest input and printer drivers as well as the upgrades and fixes to various applications; order new GEOS products directly from BSW; share GeoTips, GeoTricks, GeoDocs, and GeoHacks with fellow GeoUsers; and access the 'official' GeoLaser printing service. You can even, as is becoming more and more common, vent your GeoFrustrations by posting your GeoFlames for others to read.

But Q-Link is not the only network which supports GEOS users with message boards and download library sections. Personally, I prefer GENie to QLink. But in spite of that and its two great Commodore SIGs - Flagship Commodore (64/128/GEOS) and Starship Amiga, GENie is not yet *the* place to be for GEOS users. GEOS support on GENie's Flagship Commodore is only a few months new. In terms of support from either Commodore or BSW, the GEOS sections on GENie are something of a poor relative compared to Q-Link, but all the pieces - message board and library areas - are in place, the sysops and veteran users on GENie - \*deb\*, Gayle Tiglon and others - have a lot of heart as well as expertise to offer.

For those interested in obtaining Mac or IBM

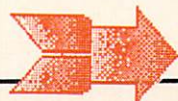

files for printing out or converting to GeoPaint format, GENie has the advantage of having those SIGs and their art libraries right there and available online just a single MOVE command away.

Costwise, the per hour GENie fee (\$5.20 per hour in non-peak periods, 300/1200 bps) is a little higher than that for QLink Plus services (just about every service these days) and some other networks. But since you can use a *real* terminal program with real options and controls, and since XModem is measurably faster than the protocol used by QLink, and since you don't have to pay an automatic \$9.95 monthly fee whether you log on or not, the costs per online effort average out to about the same for the two services.

## GEOS CONVERT

GEOS uses the peculiar USR file format to store data and programs on disk. Transferring these files types via modem can be troublesome and is not usually supported. To improve the reliability of transferring GEOS files, BSW has placed in the public domain a couple of 'Convert' programs which change a GEOS program or datafile into standard Commodore SEQential or PRoGram file formats, which can then be easily and reliably transferred via modem. After it's received, the SEQ (or PRG) file can then be changed back to into a true GEOS application or document using the same Convert program.

So the first thing to do before downloading any GEOS files is to download or otherwise get a copy of GEOS Convert. If you're up on QLink, download their SEQ file version. GENie users should get the PRG file version from the Flagship library. Apparently neither of these Convert programs will work properly under the 128 version of GEOS. Instead, C128 GEOS users are directed to a 128 version of Convert on the back of their boot disk.

## THE GOODIES

Naturally, the real reason for going through the whole Convert hassle is to get to the goodies that can be downloaded from the networks. Many of these are beginning to show up in the public domain libraries of Commodore user groups everywhere - virtually all of it via downloads from either QLink or GENie.

The 'goodies' fall mainly into five categories: BSW upgrades, GeoWrite files, GeoPaint files, GEOS programs, and non-GEOS programs which boot from (and occasionally reboot)



*MacPaint image converted to geoPaint format.*

GEOS. These programs fall into two main categories - utilities and game. For now, I skip the (boring) upgrades, the (boring, but sometimes useful) textfiles, and the (useful, but always boring) utilities and get right to the pretty and fun stuff.

## GEOS GRAPHICS

Of the two applications GEOS comes with, GeoPaint is the most fun. It is alone in its class when it comes to the size of its printouts. The novel potential of full page high resolution graphics has not yet worn off for most GeoArtists and GeoArt aficionados. As proof, GeoPaint files are among the most popular uploads and downloads in the GEOS sections of Q-Link and GENie. Once again (do I tend to overclassify?) there are three main areas into which these GeoPaint files fall: native GeoPaint compositions, conversions from other Commodore graphic programs (Doodle!, KoalaPaint, Flexidraw) and conversions from other computers types - chiefly the Apple Macintosh.

## NATIVE GEOS

The subjects for the GeoPaint artist vary widely, as does the quality of the works entering into the public domain. But there are some themes which recur more than others: cartoon, D&D and other fantasy characters; mechanical devices (especially cars and planes); keyboard

overlays and templates of various types; conversions from Doodle!, Flexidraw and the Print Shop; drawings of popular personalities; and the list goes on.

Topping the list, though (and who could have guessed it?) would seem to be that perennial favorite: the female nude form - or something vaguely approximating it. Tony Valve, with his decidedly Nagelian touch, has emerged as an early favorite. Unfortunately, at the other end of the scale are 'works' which more closely resemble the stuff frequently scratched with carkeys and penknives into the walls of public bathrooms. Some manage to insult both 'art' and 'the female form' in one fell stroke - or at least very few. Out of courtesy, I won't offer names. Be sure to check any posted comments from other downloaders (where available) before spending precious download time. On Q-Link, these comments are posted in message bases accompanying the download files. On GENie, a special comment area is designated in the regular message bases.

## MAC CONVERSIONS

Some of the hottest items for GEOS downloaders are Macintosh graphics that have been converted to GeoPaint format. There are two ways to go about collecting these gems.

One approach is to download completed conversions. Q-Link is currently the best place for this. Look for just about anything uploaded by 'Fleximan'. *Waterfall*, an Escher illusion which has appeared in several user group newsletters, and *Zebra Lady* are two excellent examples of ready-to-go Mac conversions.

The other way to go is to download your own Mac pictures and convert them yourself with *MacGeoPaint*, a public domain utility that runs from and is written in BASIC. Early versions converted MacPaint files into eight Doodle! format files, which could then be GeoGrabbed. The newest version, *MacGeoPaint 1.1*, is Blitzed and eliminates the intermediate Doodle! step, making it much easier and faster to use, although conversion still takes a little time. I downloaded my copy from GENie.

Of course, you have to supply your own MacPictures to convert, and for this GENie (or any network of BBS with a MacPaint download section) is the place to be. Gaining access to the over 4000 MacPaint files on GENie is a snap. Just join the Mac SIG! It doesn't require extra money or owning a Macintosh. Select 'Apple' at the main PC SIG menu board and follow the yellow brick road. Or you can teleport directly

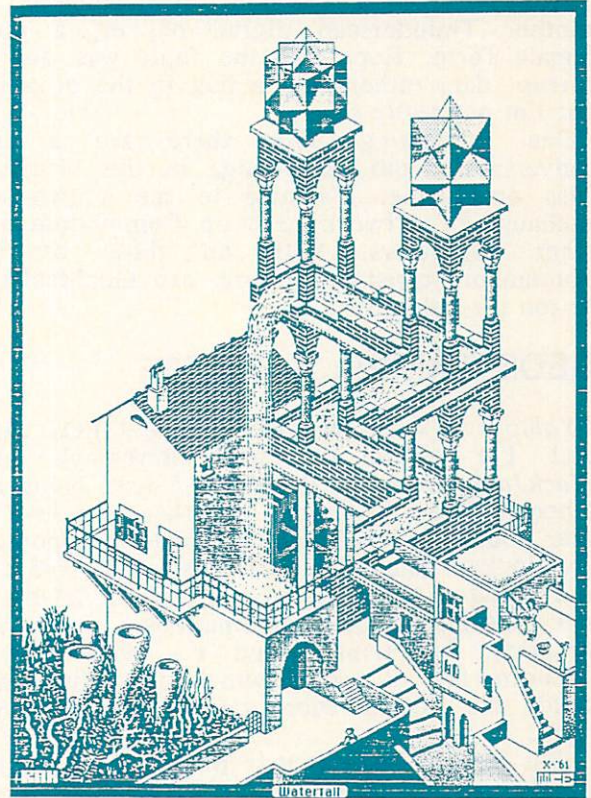

*M.C. Escher's Waterfall, converted from MacPaint to geoPaint format.*

to the MAC libraries by entering 'MOVE 606' at most prompts. Navigating the Mac libraries is exactly the same as in the Commodore section on GENie. Trying to capture the MacPaint library directory is guaranteed to stuff the buffer on your favorite 64 terminal program several times over. Downloading requires using the same XModem protocol, and as for file type, select either PRG or SEQ - neither the MacPaint file or MacGeoPaint 1.1 will care which one!

The Mac RoundTable lumps all Mac art into the single MacPaint library. Note that MacGeoPaint 1.1 will not work on compressed Mac PackIt files: similar to ARCD files, but with '.PIT' or '.P2T' extensions on the filename. Furthermore it apparently does not work on files from MacDraw (another Macintosh drawing program) so those files are to be avoided, too.

My own results have been mixed. Two of three files I tried to convert came up with misaligned pixel rows: only one row in a Thunderscan digitized image of Escher's

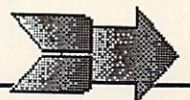

'LIZARDS', but a bunch of them came up in another Thunderscan digital of, er, a nude female form. Hopefully the fault was due to corrupt data rather than a bug in the program, but I'm not really sure.

One interesting note: there are a few conversions from the Amiga in the MacPaint files on GENie. It's nice to see a two-way exchange of artwork between Commodore and other computers. With all those aspiring Commodore artists out there, can GeoMacPaint be too far behind?

## GEOS GAMES: YAHTZEE

*Yahtzee* is only the second true GEOS game that I'm aware of, with Berkeley's own *BlackJack* (from the *DeskPack I* disk) being the other. If there are more out there I'd love to hear about them. This one recreates the popular dice 'poker' game. The object is to roll five dice and achieve the highest score while trying to roll specific dice combinations, or hands: straights, full houses, and #'s of a kind - including five of a kind, which is a Yahtzee and yields the highest score possible for a single hand.

This version is for two players only, but I found it a lot of fun to play solitaire (both sides) and test out different strategies. I also found it easy to inadvertently select the wrong hand when tallying a score, with no way to undo the error. It would be nice to be able to click on the names of the combinations being tallied rather than the little boxes preceding them. But overall the player interface is very well done and the action is fast, easy - and tense when the score is close and you're down to your last few turns.

## FINAL THOUGHTS

By next time, I'll be able to offer a peek at some of the new BSW titles that should be available any day now (as I write.) I've already got a copy of the C128 GEOS, and geoPublish is coming in a few days.

Now, about the GeoFile replacement policy and the whole way the GeoFile episode was handled: In my opinion, GeoFile should have been pulled off the shelves as soon as the full extent of the bugginess was realized. That was the only really fair course of action. It is too late to change things now, but I hope BSW keeps it in mind if there's a 'next time'.

Furthermore, the new fixed version of GeoFile

should have been shipped automatically to registered GeoFile owners without requiring any further action on the user's part, especially the return of the faulty original disks to BSW at the user's expense. If BSW wanted the bad disks back, they should at least have had the class to spring for the postage and handling.

If in fact, BSW finally decides (or has decided) to 'do the right thing' I hope that they will accept my apologies for even bringing the matter up. But if they continue with the plans for remedy that they are presently suggesting, it's my estimation that BSW will deserve 74.13%\* of the abuse (obscenities excluded) that will surely be heaped upon them.

Coming soon: C128 GEOS and geoPublish!

\* The exact percentage was calculated from a fairly complex statistical formula involving concurrent Markov chains that I hope to be porting over from Multiplan to GeoFile very soon.

Abacus Software  
PO Box 7219  
Grand Rapids MI 49510  
616-241-5510

Berkeley Softworks  
2150 Shattuck Ave  
Berkeley CA 94704  
415-644-0883

Commodore Business Machines  
1200 Wilson Dr.  
West Chester PA 19380  
215-431-9100

GENie  
401 N. Washington  
Rockville MD 20850  
800-628-9636

GEOWORLD  
38 Santa Ynez Street  
Santa Barbara, CA 93103

Midnite Press  
PO Box 1747  
Champaign IL 61820  
217-356-1883

Mister G  
21634-A Belshire Avenue  
Lakewood, CA 90716

Mystic Jim  
2388 Grape  
Denver, CO 80297

QuantumLink  
8620 Westwood Center Dr.  
Vienna VA 22180  
703-883-0788



**ABOUT THE AUTHOR:**  
INFO Contributing Editor Don Romero is the editor of the Western Indiana Commodore Users Group newsletter, Word Wrap. He is also the devilishly clever mind behind the C.H.U.M.P. magazine parody in issue #15. He's on Qlink as Don Rom.



COMING SOON

# GeoPublish

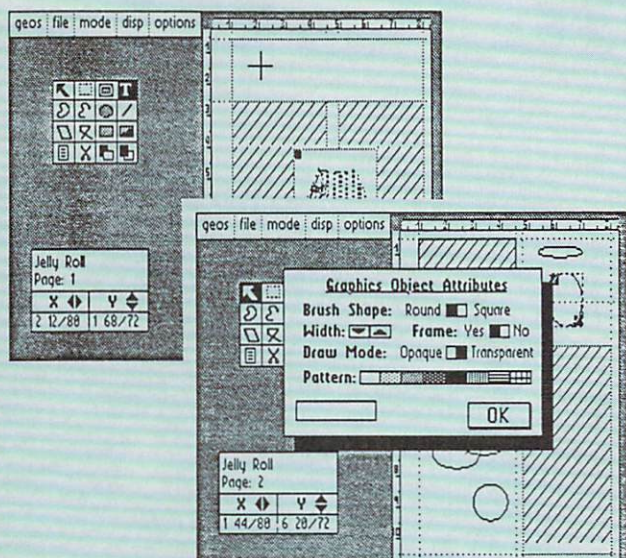

When you speak of desktop publishing, it's easy to get sidetracked into discussions of which computer is best, which printer is best, which user interface is best, and so on. But the truth is that the person holding the finished product doesn't care where it came from. All he cares about is how it looks, and he can't tell by looking if it came from a PC, a Mac, an Amiga, or even the lowly Commodore 64.

The 64 is an 8-bit machine running at 1 MHz with only 64k of RAM, and desktop publishing is a demanding job. With all those fonts and graphics, it's extremely memory-intensive. When you consider all that's involved, it's something of a minor miracle that anyone even thought of creating a desktop publishing package for the C64. But that's just what those *GEOS* folks at Berkeley Softworks have done.

We'll leave a full review of *geoPublish* for Don Romero to tackle next issue. It just came in a few days ago, and we haven't had time to give it a thorough going over. But, as a first impression, it looks like it will do the job, given some patience. And the output looks every bit as good as that produced by other desktop publishing machines.

*GeoPublish* lets you set up master pages that define the margin and column setup of your general page layout. From there you move to a page layout screen on which you put together the text and graphic regions for each page. You import *geoWrite* text and *geoPaint* pictures to create your pages. There's also a page graphics mode for doing headlines, captions, boxes, lines,

circles, and fill-pattern screens. The tools look to be adequate to the task.

The good news is that nothing other than your original *GEOS* disk is required for you to run *geoPublish*. *GeoPaint* and *GeoWrite*, both of which are included on the *GEOS* system disk, are the only tools you need to produce the text and graphics elements you need to create pages.

On the other hand, Berkeley recommends you add a 1351 mouse, a 1764 (or 1750, if you own a C128) RAM expander, and a copy of *GeoWrite Workshop* (formerly *Writer's Workshop*). These tools will greatly enhance the speed and efficiency of page layout operations. And an Apple *Laserwriter* (\$6000 or so) makes a nice addition to the system, too...

I think that with the introduction of *geoPublish* we can look forward to a really great looking bunch of user group newsletters in the coming months.

NEWSLETTER of the Students & Staff of the Bay Area Head Injury Center in Berkeley California // September/October Issue

## LIFE AFTER BRAIN INJURY

### THE PERSONAL STORY

Long after the trauma, with the crisis period passed, and the brain injured person active in both physical and cognitive therapies, the toughest part of recovery begins. In these three accounts you will read about personal relationships lost, careers altered, mobility curtailed. You will also share in the feelings of people facing monumental personal changes with a life affirming grit.

#### JAMIE AND TRACIE by Karen Greene

I've wanted to write about Jamie for a long time. Jamie was my boyfriend for about six months before I was injured in a bike/truck accident in San Francisco. Jamie and I spent a lot of time together. We went out for dinner, coffee, or I would cook at his house. He taught me how to ski and I taught him how to dance and cook. We'd swim together, bike together, watch movies on the VCR, and just be together. Even with something as mundane as shopping, we felt that if one person could do something, two people ought to be able to improve on it.

I don't remember, but my sister tells me Jamie used to come to the hospital nearly every night after work. She also says he felt guilty because we were up until 3am the night

#### WHAT! PUN?? by Will Beason

Here I am, a 21 year old guy who, pretty much, had his life set before "THE" accident in 1985. I was going to make an attempt to bike race in Europe, full time. I was also a junior in college, at the University of California at Davis. If I failed at bike racing I would fall back on my degree.

Currently, I am involved in some heavy rehabilitation after a very serious head injury. When you talk about a difference, man, I'll tell you it's like the difference between night and day, we folk!

How would you feel if the thing you loved to do most, and were good at, was suddenly taken away, with the odds of getting it back pretty dismal, if not nil? Yes, I was pretty sad too. In fact, I was so sad that I was ready to end my life. Then I thought, I've now

#### EXPECTATIONS by Leslie Blum

When it comes to working, post injury, I have discovered some very hard facts. First, I learned that going back to doing the same job, especially with a person I had worked with before, was perhaps quite a huge mistake. Second, the experience I had for myself, that I could perform as well as before, proved somewhat unrealistic.

I am a Board Certified Animal Health Technician (veterinary nurse). It is a job, unlike many others. As an AHT, the only things I cannot do legally are, diagnose, prescribe, or perform surgery. As you can imagine, that leaves a heavy load of responsibilities left for the AHT. If you have any problems, as I do, with memory, reading, or some perceptual difficulties, you are

...This newsletter page was produced on a Commodore 64 using a beta-test copy of Berkeley's new *geoPublish* desktop publishing software.



# POWERFUL CARTRIDGES

by Tim Sickbert

...How do you get printer dumps of those great Commodore 64 screens to include in your club newsletter, school report, or scrapbook? Tim Sickbert tells you how...

The Commodore 64 has been so successful for so long that it is only right that we should expect some truly amazing utilities. Some of the most amazing C64 utilities are now on cartridges which allow you to work (or play) along, stop all the action, and print out a title graphic or that fantastic graphics screen from the umpteenth level of the latest, greatest adventure game.

INFO asked me to play around with a few of these cartridges to find out what they will--and won't--do. What they *will* all do is capture high resolution (Doodle!-type) and multi-color (Koala-type) screens. Most will also frustrate you with their poor documentation. And after noting that they are all cartridges with a button or two, the similarities end.

What follows is a summary overview of each cartridge: its features; how well it worked; what was good; and what was bad. We'll finish with a few closing comments in the way of recommendations.

## BLOWUP



DSI, 717 South Emporia, Wichita KS 67211

This cartridge does screen prints and saves, period. The documentation is relatively good. It offers multiple printer support, has many options (including the ability to print "blowups" of any portion of a screen), and is the only cartridge that can handle sprites. Unfortunately, it doesn't properly save multi-color screens (which are probably a majority of the game screens out there); the only way to use a Blowup-saved "Koala" screen is with the Blowup cartridge. If you just want nice prints, this is a real contender. But the Koala-format mismatch is a major problem.

## EXPLODE V. 2



The Soft Group, P.O. Box 111, Montgomery IL 60538

Explode has many more features. In addition to the screen capture, it includes a turbo DOS, a

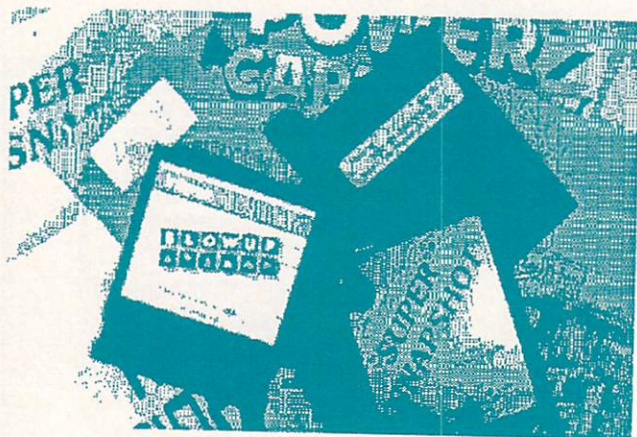

DOS wedge, and a utility called *Bootle*. The turbo DOS is the fastest of the bunch, although it bombs pretty regularly; the DOS wedge is a substandard clone of the 5.1 Wedge; and *Bootle* is supposed to create a series of loader programs that let you put your title screen in front of a Captured/Snapshotted/Isepick program. With extreme effort, it can be figured out. Most of the features work most of the time, and the rest of the features work some of the time. The nicest thing about the package is that the disk contains the public domain programs *Swinth* and *Swinth II*.

## THE FINAL CARTRIDGE\*



H&P Computers, 154 Valley Street, South Orange NJ 07079

This is the beast that started the "everything you ever wanted on a cartridge" craze; it has turbo DOS, turbo tape, BASIC 4.0-type disk commands, *BASIC Aid*-type extended editor commands, machine language monitor, Centronics printer (user port) driver, access to memory under the ROMs, and screen dumps. The list sounds pretty impressive: I just wish they all worked. Some of the extended editor commands are extremely nice, especially

\* Things never stand still in the utility market. A new, very enhanced version of The Final Cartridge with pull-down menus and tons of extra features should be available by the time you read this. There will also be a new, improved version of Super Snapshot coming in February.

'APPEND' program and the full scrolling machine language monitor, but 'CATALOG', 'OFF', and others do not work; 'DLOAD' does not relocate BASIC programs to the start of BASIC; the 'TYPE' to printer (typewriter utility) cannot be turned off, and screen dumps will occasionally screw up the screen before you tell it to start printing. We owe H&P Computers a "Thank You" for getting all this started, but they need to work the bugs out of their cartridge.

## THE POWER CARTRIDGE ★★

Kolff Computer Supplies, B.V. Dedrecht Holland

Another import, The Power Cartridge offers the same features as The Final Cartridge, plus extended BASIC commands and program capture. Of course, if you use extended BASIC commands in your programs, you have to have the cartridge to run the program. With POWER, the same is true of frozen and saved programs...POWER saves the broken program as three USER files which will not run without the cart. The turbo DOS is the slowest of the four cartridges which have it, by 50%. The reset is clumsy, either in the mechanical button or in the way the cart handles interrupts. I often had to load and try a capture two or three times before I would get the menu. And the extended disk commands are inconsistent within themselves, e.g., 'ILOAD' requires a device number but 'BLOAD' does not. Generally, it seems inexpertly done.

## SUPER SNAPSHOT V. 2 ★★★★★

Software Support International, 2700 NE Andreson, Vancouver WA 98661

Super Snapshot does not have all the bells and whistles of some of the other cartridges, but it seems to work the most consistently. The turbo DOS comes in a respectable second in load times, the wedge is fairly standard with just a few oddities to handle the turbo DOS and special keys, and the monitor is quite functional. The screen dump utility supports only Commodore 1525 and Epson-compatible printers, offers three sizes, and can use the 2 MHz mode on the C128 for printing. The cartridge will freeze and break a program as well as any other cartridge I have seen. A switch makes the cartridge totally invisible so you do not need to remove it to run C128 mode. The package includes a disk with *Kracker Jax* (tm) parameters for those programs which the cartridge will not capture, and the manual talks about a cartridge ROM upgrade policy. All in all, I think that this is the best of the bunch.

## FEATURES

Of course, the first thing to compare among the cartridges is their features. The following table shows the general features that each cartridge claims to have, with notes to indicate exceptionally high or low quality in the implementation.

The easiest feature to compare among the cartridges is the speed of the turbo DOS. The speed test is the average of loading the 99 block public domain program *Monopole* five times. Times for other configurations are provided for comparison.

Cartridge	Screen Capture	Turbo DOS	DOS Wedge	BASIC Aid	M/L Monitor	Program Capture
Blowup	Y:a	n	n	n	n	n
Explode	Y	Y:b	Y	n	n	n
Final	Y	Y	Y	Y:c	Y:d	n:e
Power:f	Y	Y	Y	Y:g	Y	Y:h
Super Snapshot	Y	Y	Y	n	Y	Y

Cartridge	Avg. time	Ratio
BLOWUP	63.5	1
EXPLODE	11.04	5.71
FINAL	12.84	4.91
POWER	18.67	3.39
S/SNAPSHOT	11.32	5.57

C64/1541	63.07	1	
C64/1571	60.12	1.05	
C128/1571	12.09	5.22	(SLOW mode)
C128/1571	11.40	5.53	(FAST mode)

FASTLOAD	12.5	5.05
MACH 5	12.2	5.17
GT4	12.2	5.17

a Multi-color pictures are not saved in Koala standard format. This means that the only way to look at it or print it is to use Blowup or to figure out how they do save it. This is the only cartridge that will print sprites.

b Explode often hangs on disk accesses.

c 'DLOAD' does not relocate BASIC programs and many of the commands do not work as documented, or do not work at all (e.g. 'CATALOG').

d An exceptionally nice scrolling machine language monitor.

e Program captures are not directly supported, but some captures can be performed with the ML monitor...if you know what you are doing. Command syntax is inconsistent.

f The reset button is particularly troublesome.

g Includes a nice extended BASIC, but remember that using these commands requires that you have the cartridge to run the program.

h The program capture works, but you have to have the cartridge to run the captured program.

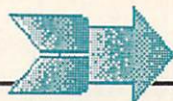

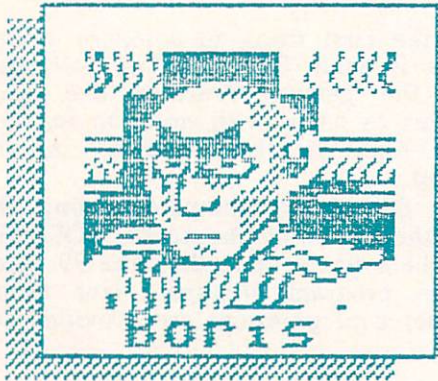

Full-sized details of screen dumps from *The Final Cartridge* (left) and *Super Snapshot* (right).

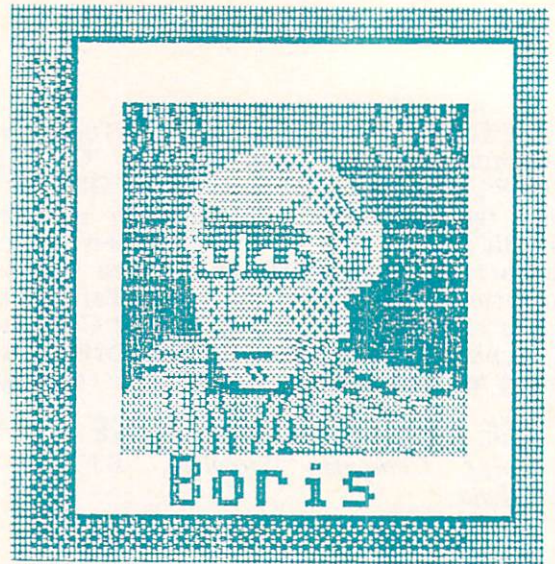

Next there is the matter of screen dumps. All five cartridges handle screen dumps in one way or another. This does not, however, mean that they are all the same. Blowup, for example, can magnify a picture 1 to 99 times in the horizontal and/or the vertical; the Final Cartridge prints in one size.

In general, all the screen dumps print as advertised, provided that the cartridge can successfully freeze the program without corrupting the screen. And *that* is the problem. There are, apparently, several different ways to go about freezing a program and no single one of them is the absolute best. One method may freeze about 80% of the most popular programs; a second method might also freeze about 80%, but it will freeze some programs that method 1 will not and not freeze some programs that method 1 will. And there may still be 10% - 15% that neither method will freeze. And so on. For example, Super Snapshot will freeze *Chinese Juggler*, *Skyfox*, and *Kung Fu Master*, but cannot handle *Defender of the Crown*; Blowup can get some, but not all screens, from *Defender of the Crown*, but will not freeze *Chinese Juggler*, *Skyfox*, or *Aliens*. There is almost no way to predict which cartridge will successfully freeze a given program and save or print the screen.\*\*

Note that none of the cartridges will print color images even if the Okimate 10 is

\*\* Here at INFO, we have been keeping all the screen-dump cartridges handy. We find Super Snapshot to be about the most reliable of the batch, but the process is so frustrating and time-consuming that we have decided to just use screen photos instead. We can get them processed and ready to print in just a few hours, and it's more reliable than trying to find a cartridge that will give us good results with a particular program.

supported. If you save an image to disk in Doodle-compatible hi-res or Koala-compatible multicolor, however, you can use the Okimate utility disk to print images in color.

## CONCLUSIONS

With all the different features and the range of hardware supported, it impossible to say that any one cartridge is the absolute best in handling the screens. Blowup would seem to come out on top...except that it does not properly save multicolor screens as Koala-compatible (standard) files. Explode and The Final Cartridge do not seem to offer much control at all. And Power falls out of the race because it cannot save pictures to disk. Super Snapshot does not have all the printer support or image control that Blowup offers, but Snapshot seems to be able to handle more screens than Blowup.

After putting all the cartridges through their paces, I found no one cartridge to be categorically the best for all situations, but I have developed a strong preference for Super Snapshot. It seems to have the best combination of useful features and seems to be the most reliable, and offers powerful program capture capabilities as well.

Remember, however, that none of the cartridges works perfectly all the time. Programmers often do odd things to get special effects and to make the screens appear more active or more attractive without slowing down the action of the game. Several games, for example, use split screen graphics with all the major action in one part of the screen and only a little action in the other; other programs use redefined character sets, which none of the cartridges can handle. Any of the cartridges can be useful, but no one of them will work with everything all the time. As long as you do not

get your expectations too high and don't promise screen prints that you have not already made, the cartridges can be a fun and useful addition to your system.

#### BLOWUP:

Printers: CBM 1525, Seikosha, Okimate 10 (b/w), Okidata, Prowriter, Epson.  
Screen Modes: text, hi-res, multi-color, sprites  
Printer Control: b&w or shade; x&y magnification(1-99x)  
Printer Density Control (up to 1920 dots per line); rotation; indentation, justification; mirror image; cropping  
Disk: save & load Doodle-compatible hi-res, and non-Koala compatible multi-color.

#### EXPLODE:

Printers: CBM [1525?], C. Itoh, Epson  
Screen Modes: hi-res, multicolor  
Printer Control: n/a  
Disk: save and load Doodle-compatible hi-res and Koala-compatible multicolor; hi-res <-> multicolor conversion.

#### FINAL CARTRIDGE:

Printers: CBM MPS 803, Epson, Smith Corona  
Screen Modes: hi-res and multicolor  
Printer Control: n/a  
Disk: n/a

#### THE POWER CARTRIDGE:

Printers: CBM MPS 801/3, Seikosha GP100VC, Epson GX 80; Epson RX 80/FT, Epson LX 80, Panasonic 1090/1, Brother HR5, Star Gemini 10X, SG10, AVT FAX 100, CP80, Smith Corona Fastext 80.  
Screen Modes: hi-res and multicolor  
Printer Control: small image normal/reverse, large image normal/reverse (non-CBM compatible only).  
Disk: n/a

#### SUPER SNAPSHOT:

Printers: CBM 1525, 1526, Epson  
Screen Modes: hi-res, multicolor, standard/multicolor text  
Printer Control: normal/reverse in small/medium/large image; 2 MHz printing on the C128  
Disk: save and load Doodle-compatible hi-res and Koala-compatible multicolor.



#### ABOUT THE AUTHOR:

Tim Sickbert was the Editor of The Midnight Software Gazette during its final year and a half of autonomy. Tim is 24 years old and holds a degree in English from The University of Illinois. His day job is writing documentation for Computer Teaching Corporation in Champaign, Illinois.



## The Real World

### MOMS, STOP CALLING

Since we printed Bryce's mom's message to her son last issue, we've been deluged with calls from other hackers' moms who want to communicate with *their* sons. Please, moms, **Stop Calling!** If you want to get ahold of your kid, you'll have to take out an INFO unclassified ad. We didn't mean to set a precedent, we were just trying to be nice guys! Sheesh!

### ENGINES OF CREATION

Thanks and a hat tip to Richard Mansfield at *Compute!* for telling us all about K. Eric Drexler's excellent book, *The Engines of Creation*. In this volume, Drexler, a Research Affiliate at MIT's AI Labs, explores the potential of wedding molecular engineering to AI to form what he calls *nanotechnology*. Where humanity now manipulates atoms in huge groups to create skyscrapers, autos, and microchips, Drexler thinks we will soon be able to create tiny AI-guided molecular construction engines that will be capable of assembling objects atom by atom. In its early stages, this new technology will allow us to make diamonds out of pencil lead; after some development, it may let us repair and modify our own bodies. Though the book digresses occasionally into his personal views about the social and political ramifications of such developments, the theory he lays out is fascinating in the extreme. These ideas are right on the radical fringe of today's science, and well worth exploring. \$10.95 in trade paperback from Anchor Press/Doubleday.

### STAR TREK: THE NEW VOYAGES

The votes are in here in the INFO offices: 2 yea, 2 nay, and 1 abstention. We "nays" say the new characters are not as endearing, colorful, and don't mesh together like the old *Star Trek* crew. The "yeas" say to give them time to work it all out and mature, because the special effects are great! At a million or so dollars per episode, lets hope they get their act together soon!

### MAX HEADROOM CANCELLED

In their infinite wisdom, ABC told the producers of *Max Headroom* that the show was too "cerebral" and cancelled it, just as it was starting to look like *Max* might be a good publicity vehicle for the Amiga. Aren't they the ones who ran *Gilligan's Island* for eight seasons?





# PRINTMASTER PLUS

by Sue Albert

PrintMaster Plus \$34.95 Kyocera Unison, Inc. 2150 Shattuck Avenue, Suite 902 Berkeley, CA 94704 (415) 848-6666	
---	--

This is a new and improved version of the original PrintMaster which produces greeting cards, posters, banners, and calendars. Includes all the old features in new dress with added printer drivers, more choice in graphic placement, two graphics in some modes, and an expanded preview function. Fun & flexible. Results can impress even the computer-phobic. SA

## AN ILL WIND?

When Unison World lost a copyright suit last year to Broderbund, the makers of *Print Shop*, they were forced by the court to change the user interface (the look and feel) of their *PrintMaster* program. They took that unplanned and undoubtedly expensive opportunity to completely reprogram *PrintMaster*. They cleaned up a few flaws, increased the flexibility with some great new features and and tied up their package with a new name, *PrintMaster Plus*.

## PLUSSES

The *Plus* of this *PrintMaster* begins with the new menu screens. The artfully arranged rectangles on the top three quarters of the screen hold the title box, the graphic box and an instruction box which gives you the current selection status. On the bottom, a horizontal box holds the choice menu. The cursor cycles around all the choices so you never have to use the shift key if you overshoot. The main menu screen holds the same items offered by the old *PrintMaster* with some new titles: Card, Stationery, Poster, Calendar, Banner, Drawing Pad, Hardware Configuration, and Exit to Basic.

In the essential first choice, the Hardware Configuration, are several additional printer drivers. A neat little printer test now allows you to properly align the paper so the printouts are correctly centered. This is a rather primitive fix for the original alignment problem, and although it works, it didn't go quite far enough. The logical inclusion of disk formatting from within the program now prevents the annoyance of coming up a data disk short. The option to change the background screen color has been eliminated, a trifle I miss.

Returning to the choice menu, you pick which item you want to print. You may want to celebrate here with a few fireworks when you discover you can now preview your selection after almost every choice. No longer working

blind will save your patience, a lot of time, and a great deal of that expensive colored paper when planning a layout.

## BORDERS, FONTS, GRAPHICS

*PrintMaster Plus* has retained the same eleven border patterns. I find the Ants, Lace, and Christmas charming, but my favorite is Cars, which I like to use with The American Gothic graphic from *Art Gallery I* to warn friends of our impending visits. One plain font has been added to the original eight, but alas, you still can't import fonts or borders from other disks.

I did mention flexibility--picture this: when you are placing the graphics in the Card or Poster mode, you have a choice of placing the two graphics on the diagonal in five areas in regular size, and thirteen in half-size. In a new Freehand option your choice expands to any arrangement of fifteen locations in regular size, or up to thirty five locations in half-size. Now let your imagination go! Have Godzilla confront a giant Teddy bear, or a large pointing hand trying to recruit an army of penguins. With this kind of picture formatting and the ability to bring in graphics from other disks, your choices become enormous. Some very nice effects can be achieved using the texture patterns or a small graphic repeat under a larger graphic, but keep in mind, if you print one graphic over another you will see the bottom graphic through any white space in the top graphic.

The Banner mode also allows the use of two graphics. If you are bothered by having both graphics facing in the same direction, try loading one into the Drawing Pad, flip it, save it, and you can print and enjoy bi-directional symmetry.

## GETTING GRAPHICS

Creating graphics with the drawing Pad in the C64/128 version is the same tedious chore it always was, using only the keyboard or a joystick for input. Although you are given running x and y positions, the tiny pixel is lost on the screen and difficult to control. There isn't a grid or fill option in the 64 version to make things easier. Unison World is looking into the 1351 mouse but has no plans at present to incorporate drivers for it or the Flexidraw Lightpen to make drawing faster or smoother. Their reluctance to do another update is understandable.

Not to worry, graphics are plentiful for *PrintMaster Plus*. The disk comes with 122 exceptionally well drawn graphics. Unison World

offer *Art Gallery I* and *II*, each with 140 graphics, and will release *Art Gallery III*, a disk of fantasy monsters and space creatures by the time you read this. There are also third-party disks available like the *Steele Disks* which give you 51 to 96 graphics for as low as \$12.95.

Conversion is another way to go. There are several fine conversion programs now available which will convert your own properly sized drawings from Doodle, Flexidraw, or most other major drawing programs, into the *PrintMaster* format. Digitized images may also be captured, saved, and converted. Why you can even (dare I say it?) convert *Print Shop* graphics to *PrintMaster*. If you still haven't found just the perfect image, there is a constant supply of new graphics, sometimes conversions, sometimes unique original artwork, available for the downloading on QuantumLink. Be forewarned, you may need to download a graphic library printout program to keep the glut under control.

## OUTPUT

*PrintMaster Plus* is about printing. From my faithful, but cantankerous, old Gemini 10x, to my friends' varied assortment of dot matrix printers and my daughter's slick new Star NP 10, I have been impressed by the fine quality of the *PrintMaster Plus* printouts. Printouts from Commodore compatibles, like the Okidata 120, will be smaller and have lower resolution, but do not require insertion of another disk as with *Print Shop*.

## DOCUMENTATION

The manual for *PrintMaster Plus*, though a bit skimpy on details, is clearly written, well organized and generously illustrated. Since it combines instructions for all computer versions in one volume, it can be a bit confusing and disappointing sifting out the options which work on the C64/128, especially since the C64/128 is never once mentioned in the manual proper. Putting aside my sensitivity, I found the included Addendum/errata sheet covered all the necessary information, but it was really annoying being treated like a poor cousin--Give us a break!

If you are a registered owner of *PrintMaster* you can receive a *PrintMaster Plus* update by sending a request to Unison World for a disk and manual with your check for \$15. A backup disk only, is \$5. If you forgot to send in the registration card, include proof of purchase.

## AMIGA VERSION

I wasn't able (yet!) to personally test



*PrintMaster Plus* for the Amiga. It includes additional options. In the Text Editor, Rain and Checker patterns are added to the texture selection. The more important difference is in Drawing Pad where the mouse is a superior input device for drawing and there are windows for manipulating sections of the graphic. The disk comes with a program for converting *PrintMaster Plus* graphics into IFF-compatible files.

The Amiga *Art Gallery I* and *II* disks contain the same 140 graphics, which leaves each less than 15% full. Just released is a wonderful new disk of *Fonts & Borders* with 20 of each. An Art Nouveau font called Paris and the zany Twigs are star quality, while Joyce, a really lovely script, ain't chopped liver. The borders are going to charm you. There are black cats, elephants, and dinosaurs, but my prize goes to City, where a whole block of apartments borders the page with a sidewalk full of pedestrians and laundry on the roof. With *Fonts and Borders* you receive two disks. One disk updates your *PrintMaster Plus* so you can import fonts and borders from other disks.

## A FINAL NOTE

Not every company could survive the expense and agony of a lawsuit requiring major reprogramming. Unison World toughed it out with style, made lemonade from their lemons, and came up smelling like a rose...by any name.



### ABOUT THE AUTHOR:

Sue Albert is a completely right-brained artist, the combination of a gift C64 in '83, with Easyscript inspired this grandmother to write software reviews from the viewpoint of the total end user. Last year she self-published a book of poetry and computer drawings. You can EMail her on QLink as Suzart.



# THE TOY SHOP

by Sue Albert

The Toy Shop \$29.95  
Broderbund  
17 Paul Drive  
San Rafael, CA 94903-2101  
415-492-3500

INFO-rated



A toy store in a box. Complete with supplies to print and build 20 different working paper toys. Charming, solid program lets you customize and replace parts. Terrific printouts. 40+ dot matrix printers supported, but printout times are extremely long. Manual is coffee table quality. Possibly a classic at an attractive lower price, it's custom-made for holiday giving. SA

## A MODEL PRODUCT

In 1942 I had my first encounter with model building. My father commandeered our dining room table and for weeks I watched him patiently cement and pin together balsa wood struts for his gas engined freeflight model planes. He covered them in silk, glossed by coats of airplane dope. They were flown over fields of lupins, now the smoggy freeways of Los Angeles. Later my sister and I put together P38's and B59's, cut from the back of the corn flakes box. A penny in the nose and daddy's advice and it was "Off We Go..." Currently my son builds radio controlled model planes, with flawless, heat shrink skins.

## NOSTALGIC HI-TECH

In the *Toy Shop* program (*Marvelous Mechanical Models That Really Work*), Broderbund has combined the nostalgic low-tech paper models like the planes I once built with high-tech computer customization.

The first thing to impress me about the *Toy Shop* was its weight. The attractive and sturdy box comes packed with 24 sheets of adhesive cardstock for mounting the model printouts, a kit including rubber stripping, balloons, tiny dowels and wire, three two-sided floppy disks and a sleek two hundred and nine page manual.

## TOY SHOP: THE BOOK

You won't need my encouragement to give this beautiful manual a good read before using the program. The first forty pages give very complete instructions for using all the functions of the program, enhanced by illustrations of the screens you will see. The writing is clear, non-technical, and refreshingly free of cuteness.

There are two pages of welcome Printer Tips; the *Toy Shop* has drivers for over forty printers

and supports eight different Commodore interfaces. The programmers at Broderbund spent a lot of time on the printer drivers to achieve the accuracy required to make all the printed model pieces fit together with precision when assembled. The *Toy Shop* will not work with the VIC 1526 or MPS-802 and you will get slower printouts with lower resolution from VIC-1525 and MPS-801 printers. A paper alignment test in the program will help you properly positioned the printhead.

The next six pages are a Construction Guide filled with techniques for assembling the toys. You'll learn how to drill holes, score and cut accurately, and put the little finishing touches on a toy to make it work well and look even better than the picture-perfect examples shown.

The largest section of the manual covers each toy individually, with clear photos of the finished toys and lists of all the materials you will need for their construction. The tools required are: sharp scissors, a hobby knife, white glue, super glue and a metal edged ruler. Most other materials are common to most households, like table salt (to weight wheels), straight pins, or thread. The book also contains diagrams marking all the areas where you may computer-customize the designs. Step by step text instructions guide you through to the final adjustments on the finished toys. The book finishes up with an invaluable illustrated index of all printed sheets.

## THE TOYS

The twenty toys included in the *Toy Shop* vary from easy to challenging. These are beautifully detailed models of various real and imaginary vehicles and machines. Many have an old fashioned charm; all are ingenious. A balloon powers the piston and turns the crankshaft of the Steam Engine, a rubber band causes the Oracle to leap in the air and wittily make a decision for you, airplanes fly, a scale is calibrated to give accurate weights, and the Zeotrope shows two movies. There is something to appeal to the child in most of us.

## CREATING A TOY

Once you are familiar with selection and assembly, your fingers will itch to get to the keyboard and create a toy. The *Toy Shop* program will be instantly recognizable to *Print Shop* users. It is completely menu driven and very user-friendly in the best sense of that



overworked phrase. You are never dead-ended in this program with its everpresent "go back" option. You may save and load favorite customized toys and format a data disk. Though you can view any *Toy Shop* files on a disk, it's annoying that you can't check to see if you have room for additional files.

Model makers must have patience. Users of *Toy Shop* must have *patience plus!* This program takes time. Disk swapping with one drive is an acceptable three or four swaps when you customize. When you choose a toy with the preset options you will spend less time with the program, but still considerable time in printing. If you choose to customize, extra time is added to the printing, and even more time is spent Thinking between printing. A two page printout of the Experimental Glider with a dense checkered pattern and custom lettering took 55 minutes to print on the Star NP-10. More than half the time was Think time. A benefit from all this celebration is that the print head never became more than lukewarm. I thought this might have been an intentional courtesy, but was told by Broderbund that the delays are caused by "the nature of the C64 in processing so much information".

## TOYS ON PAPER

The printouts from *Toy Shop* are knockouts! There are 30 varieties of Paint (a misnomer for texture patterns) and you have options to apply "decals" (printed-on emblems). You can change or create your own designs for both the decals and paint patterns, using a joystick in separate editing programs exasperatingly similar to those in *Print Shop*. These can be saved to grace a future toy. You can also bring in graphics from *Print Shop* to use as decals on your toys.

There are four fonts which can be printed in combinations of five styles for personalized nameplates and credit lines. Changing fonts or styles from the preset configuration can limit the length of the text, but you are warned of this fact by a rather startling chime and a message before you proceed.

You may add color to your toys with colored paper and colored ribbons. Hand coloring is another possibility. I found it helpful to spray the printout paper several times with a workable fixative (available at art supply stores). This sets the ink so it won't bleed when using felt tip art colors. A few coats of artists' glossy acrylic spray will give a toy a bright store-bought look.

## SOME ASSEMBLY REQUIRED...

The *Toy Shop* is recommended for people over

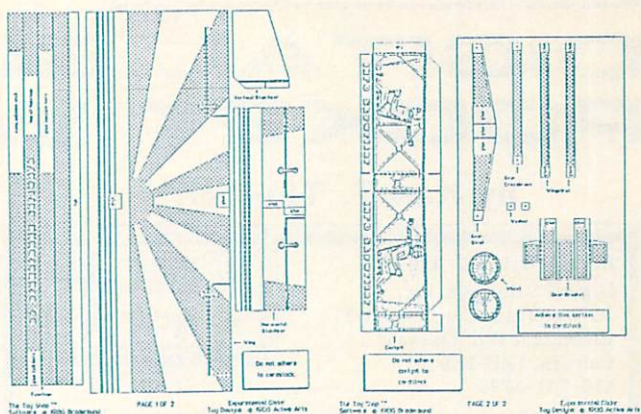

*Toy Shop* model ready for assembly. A reduction of an actual Gemini 10X printout.

12 because of the sharp tools and powerful glues required in assembly. With adequate supervision many younger children may be ready to use *Toy Shop*. If not, they could have an equally good time choosing their own design options and watching a parent or grandparent put together a toy made 'specially for them. The personalized and assembled toys would make wonderful gifts, favors or prizes.

Refill kits of supplies are available where the program is sold or directly from Broderbund. Most of the items can be purchased separately at hobby stores, art shops, and hardware stores. The gummed cardstock may be harder to locate, but you can make your own using the same gauge cardboard and an artist's spray mount adhesive. Broderbund has a new phone number (not the one on the manual) for software, supply orders, and tech support. It is 415-492-3500.

## BACKGROUND

The *Toy Shop* was born when creative hobbyist Kyle Wickware, who owned a real toy store, met and collaborated with Jim Calhoun, who conceived the idea of using a computer to design and customize the toys. Kyle had previously published two books, *Make Your Own Working Paper Steam Engine* and *Make Your Own Working Paper Locomotive* (Harper and Row). Jim Calhoun has created many additional clever mechanical paper toys for Broderbund which may be released at a later date.

The *Toy Shop* is an example of what can happen when software developers go all out on a product. For me it was a kick to find that after forty years of inflation, a penny still works to counterbalance a paper airplane.

*...Broderbund has just announced a second price cut on the Toy Shop, to an economical \$29.95.*



# DIGITAL SUPERPAK 2 POCKET WRITER 2

by Karl T. Thurber, Jr.

Pocket Writer 2 \$59.95  
Digital Solutions, Inc.  
30 Wertheim Court, Unit 2  
Richmond Hill, Ontario  
Canada, L4B 1B9  
416-731-8775

INFO-rated



Pocket Writer 2 is probably the best of the Commodore what-you-see-is-what-you-get wordprocessors -- it has virtually all the formatting and word manipulation features you could expect in a wordprocessor, and then some. The fact that both C64 and C128 versions are included is a strong plus should you upgrade your computer system. One major caveat is the heavy copy-protection. KTT

Digital Solutions' *Digital Superpak 2* is a bundle of its three best-selling Commodore 64/128 productivity products, the *Pocket Writer 2* wordprocessor, *Pocket Filer 2* database, and *Pocket Planner 2* spreadsheet. Each is a completely separate package that may be purchased individually for \$59.95. The program disks are 'flippies,' with the C64 version on the front side and its C128 counterpart on the flip side.

This time we'll review *Pocket Writer 2*. Next issue, we'll examine the *Filer* and *Planner* components. Remember that while we'll stress Superpak's data exchange capabilities, each of its three components -- wordprocessor, database, and spreadsheet -- is a stand-alone product that can be used separately either on the C64 or C128.

## BASIC FEATURES

*Pocket Writer 2* is perhaps the most sophisticated product in the Superpak bundle. It offers considerable wordprocessing power, particularly in the C128 version, which offers more advanced features. With it, you can create, edit, and rearrange text with ease, and you also can interchange data with sister Superpak programs. It is a true what-you-see-is-what-you-get, or WYSIWYG, wordprocessor. This means that, in almost every circumstance, what you see on your screen is exactly what will be printed -- including such print enhancements as italics, boldface, and underlining displayed on-screen. For many people who have trouble interpreting the results of obscure imbedded format commands, the WYSIWYG feature is a welcome relief.

*Pocket Writer 2* has the most-wanted

wordprocessor features; to name them all would make boring reading. Suffice it to say that the programmers haven't forgotten any of the wordprocessing basics or left out any necessary capabilities in adding the many 'bells and whistles'.

Text entry and manipulation features are extensive. The software allows you to easily move, insert, and delete text; search for and replace text; print underlining, boldface letters, superscripts, subscripts, and other special effects; indent paragraphs as desired; automatically justify and center text; produce headers and footers; link long-document disk files; spell check and word-count documents; and automatically paginate and format text.

Most of *Pocket Writer 2*'s functions, controls, and commands are activated using various CTRL-key and COMMODORE-key sequences. Many of these are displayed in a placard above the text editing area; you can also access built-in context-sensitive help screens or refer to the quick reference chart in the back of the reference guide for more help. The top of the screen also displays the command line, to give you a running check on the cursor's page, column and row, and provide other useful information.

Advanced features include automatic wordwrap in insert mode; transposition of letters, words, sentences, and paragraphs; change case (upper to lower and back) when defining ranges; negative paragraph indentation; file joining; and GEOS file compatibility. You also have control over the screen display, printer, and other program defaults with the adjustable configuration file. Once you make changes to the default settings, the new settings load each time you boot.

In C64 mode, if you have a C128 the numeric keyboard works, along with several of the C128's special keys (HELP, ESC, TAB, etc.). Too, in C64 mode you can use either the regular 40-column screen or a bit-mapped 80-column screen. However, there's a penalty in terms of working memory, as only about 5.9K are available for documents in the C64's 80-column mode, as contrasted to over 11K in the 40-column mode and more than 57K on the C128. Still, you can dump the help option to regain about 5K.

## ADDED C128 FEATURES

It's in the C128 mode that *Pocket Writer 2*

shines. Nice extras include a RAM disk for use with a memory expander, mouse capability, fast 1571 'burst' file loads, flexible disk drive assignment, a built-in 80-column spelling checker, an optional 50-line video display, and alternate (two-file-in-memory) editing capability.

The RAM disk support is the most potentially useful extra feature. It allows you to use a Commodore 1700 RAM expansion module for 128K of extra memory, or a 1750 module for 512K, to store files for near-instantaneous access. The module is used as an extra disk drive. You can use it to temporarily store whole disks and files and to do fast spell checking with the dictionary copied to the RAM disk. Of course, the RAM disk is a temporary working aid, as the contents are lost when you turn off your machine -- unless you first save it to a floppy.

Another feature is the optional use of rodents: either the Commodore 1350 or 1351 mouse may be used. By moving the mouse, clicking and pointing your way, you can move the cursor, define ranges, access the pull-down menus, and select and execute various options. I found that a regular joystick also works quite nicely.

You can alternately display 50 horizontal lines on your screen if you choose, instead of the normal 25 lines; this allows you to see more of the current file without scrolling. The characters are smaller than the regular characters and there is some flickering, so you have to experiment with the screen colors to get a steady display. (I was able to get a steady, highly readable display by doing so, and liked the effect.)

Although *Pocket Writer 2* is almost overloaded with features, there are a few things it won't do. It won't conveniently handle true, bottom of the page footnotes. Too, it won't do newspaper style multiple column printing or document indexing, and no outliner or thesaurus is included. In fairness, with the exception of the thesaurus, few Commodore wordprocessors are equipped to handle these demanding, memory-hungry tasks.

## THE SPELLING CHECKER

The spelling checker allows you to check your documents against a 32,000 word main dictionary (not included) and up to 8,000 additional words you've added. Once it is engaged, you can skip unrecognized words, add them to the dictionary, or change the word in your document. The C64 version spelling checker is a separate program module, meaning that you must save your document first and then use the spelling checker, which works on and

# Pocket Writer™ 2

corrects your document file on disk rather than in memory.

The spelling checker is built into the C128 program. This makes for more convenient and efficient operation, as documents are checked in-memory; you need only resave the document after making spelling corrections. Two handy bonuses: the C128 version also works with the memory expander, allowing you to copy the dictionary into the RAM disk before starting up the spelling function; and the C128 spelling checker also shows words not found in the dictionary in context.

## AN INTEGRATING APPROACH

Digital Solutions promotes the fact that the three Superpak programs can freely interchange data: all Pocket series software produces files usable with one another. Data from *Pocket Filer 2* can be merged into wordprocessing files using *Pocket Writer 2*'s mail merge function; this can be used to print individualized form letters. Graphs and tables created by the *Pocket Planner 2* spreadsheet can be included in *Pocket Writer 2* wordprocessing files, and *Pocket Planner 2* spreadsheets can be piped into *Pocket Writer*. Also, database files from *Pocket Filer 2* and other database managers that use sequential files can be loaded into *Pocket Planner 2* spreadsheets and used in calculations. Handily, you can use the printer files from any Pocket program with any other.

Digital Solutions properly refers to the data exchange feature as an 'integrating' process, rather than calling Superpak 'integrated software' -- which it is not. True integrated wordprocessing, database management, and spreadsheet packages unfortunately are not practical for the C64 and C128, as they would require upwards of 256K RAM, and preferably much more memory, for all of the programs to be simultaneously resident in memory. Superpak is more correctly described as integrating software, as it lends itself to easy, but not instantaneous, exchange of data. These semantics constitute a fine distinction, but are something to consider as the overworked and overblown 'integrated software' buzzwords become everyday computer slang.

## FIRST, THE PLUSSES...

What do you say about software when it's 'almost perfect?' I was impressed with *Pocket Writer 2's* crisp, professional performance. The 128 version, especially, includes most of the advanced features that the serious user might expect in a wordprocessor. Too, what you see displayed on your screen is probably unmatched by other Commodore WYSIWYG wordprocessors, and certainly not by format-command programs that require you to enter a separate viewing or preview mode to see what the document will actually look like.

Another thing is *Pocket Writer 2's* economy, especially if you purchase it as part of Superpak. Superpak costs \$99.95 and also includes sister programs *Pocket Filer 2* and *Pocket Planner 2*. Each costs \$59.95 purchased individually, so that's one clear economy. Another is that both C64 and C128 versions are included in the same package. This means that you can start out using the C64 version and upgrade to the C128 without having to purchase and learn a new program.

I also liked the well written, 72-page reference guide. It was crisp, concise, and well-organized. The same guide is used to cover both versions: common material is in standard black-on-white, while information pertaining only to the C128 stands out by overprinting the text on a light blue background. Other than the lack of tutorials, my only real complaint about the manual was the fact that I had to use my bifocals to read it: it uses a very small typeface.

## AND THE MINUSES...

While *Pocket Writer* is perhaps the best all-around WYSIWYG Commodore wordprocessor you can buy, even *Paradise* isn't perfect. One annoyance was the spelling checker: while the speller (a relatively slow one) is included, the dictionary disk is a \$14.95 option. You must either build your own dictionary from scratch or pop for the add-on. This choice seems unreasonable, particularly since the add-on dictionary only contains 32,000 words, which is paltry compared with the 80-100K word dictionaries many wordprocessors now offer. Too, a thesaurus is not included (it is with competitors *Fleet System* and *Word Writer*) -- but maybe I expect too much for my money!

Another annoyance was the lack of significant tutorial or sample files. This lack stands out in view of the tremendously complex package having scores of features and options that need work-through examples. Actually, there isn't room on either side of the program disk to include such files, since the dozens of printer

files fill both sides. I suggest that Digital Solutions include an accessory disk that includes a decent-sized dictionary, tutorials, and example files.

By far my greatest objection was the heavy copy protection. We all know the reason for this, but if Digital Solutions is going to promote Superpak as a high productivity business application, the copy protection -- which prevents you from making a backup -- needs to be reconsidered. As more 'power users' use hard disk (HD) drives, they will become more vocal in protesting protected software, which makes HD installation much more complicated than it has to be. While Digital Solutions offers a backup disk at \$10, this doesn't solve the problem and inconvenience of dealing with copy protection for the legitimate user.

## THE BOTTOM LINE

The many features of the Superpak wordprocessor, *Pocket Writer 2*, far outweigh any negatives. I rate it a very strong and feature-laden program, the best of the WYSIWYG Commodore wordprocessors. It's powerful enough for small business use, while at the same time it's not intimidating to the beginner and need not be operated with the manual in one hand. Its many advanced word handling features and formatting capabilities are just right for the serious user who wants his or her documents to have a truly professional appearance. For my software dollar, *Pocket Writer 2* is a superb value -- particularly if you want to cover your bases on both the C64 and the C128.

...Next time, *INFO* will look at the other two Superpak components, *Pocket Filer 2* and *Pocket Planner 2*, stressing both their individual capabilities and their integrative features.

\$99.95 (U.S.) for Digital Superpak 2 (tm)  
\$59.95 (U.S.) for *Pocket Writer 2* (tm) only  
\$14.95 (U.S.) for optional Dictionary Disk  
\$19.95 (U.S.) upgrade PW1 to PW2



### ABOUT THE AUTHOR:

Karl T. Thurber, Jr. is a veteran of 22 years with the Air Force and is now pursuing fulltime graduate studies at Auburn University. Karl's been into writing electronics, computer, and amateur radio articles since the mid-1970s, and he now has more than 150 to his credit. He's a member of his local users group, the Montgomery Area Commodore Komputer Society (MACKS).



# TRUE BASIC

by Warren Block

## TRUE BASIC

True BASIC Inc.  
39 South Main Street  
Hanover NH 03755  
(603) 643-3882

INFO-rated



A compiler designed to address the flaws in BASIC, by the original designers of the language. Excellent for math and graphics. Programs are easily portable to MS/DOS and Mac environments, but this portability limits access to the Amiga's special capabilities. Libraries are available; the 3-D Graphics library is almost a must. -WB

Why would anyone want to write serious programs in BASIC? After all, it's slow, clumsy, and interpreted. But there are those of us who actually *like* BASIC. It's comfortable, like old tennis shoes. And so what if it isn't the most powerful language to program with?--it's easy to get small projects done quickly.

John Kemeny and Thomas Kurtz, the original creators of BASIC, grew unhappy with the versions of BASIC widely available for microcomputers. "Street BASIC" (as they call it) varies widely from machine to machine, and also fails to meet their original design concepts for the language. So they created *True BASIC*, a compiler that accepts their version of the language, and also follows the ANSI BASIC committee's guidelines closely. *True BASIC* is available for Amiga, Mac, and MS-DOS systems, and source code is meant to be highly portable among them.

## ENTERING A PROGRAM

After running *True BASIC*, the full-screen editor is used to enter programs. Consistent and simple to use, the editor has all the conventional Amiga gadgetry, including pull-down menus (with keyboard shortcuts), requesters, and scroll bars. The function keys are all assigned, and an assignment template to fit into the keyboard cutout above them is included. There aren't many frills, but compared to the AmigaBASIC screen editor, it is a real improvement. If it isn't powerful enough for you, programs may be written with another editor, then loaded into *True BASIC*.

## LANGUAGE FEATURES

*True BASIC* and AmigaBASIC are similar in many ways: line numbers are optional; variables may have long, meaningful names; subroutines are allowed to have local variables. But there are some differences that require an adjustment

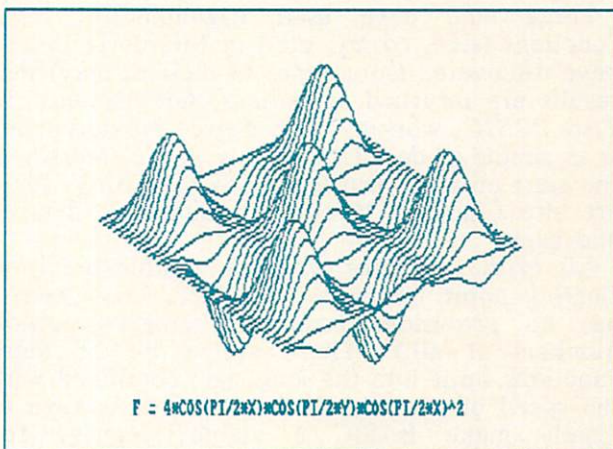

3D plot created with *True BASIC*'s 3D libraries.

on the programmer's part. Use of the LET statement for assigning values to variables is no longer optional, and there are other changes in the syntax of the language. Thankfully, many of these changes are the result of added features.

Like AmigaBASIC, subroutines can have local variables that aren't accessible by other routines; unlike AmigaBASIC, the values in local variables are cleared each time the subroutine is executed. Parameters passed to a subroutine or function can include arrays with open size definitions, like A(.). The UBound and LBound functions provide an easy method of finding the upper and lower bounds of such arrays, making it easy to write general-purpose routines for dealing with arrays.

The Key command allows you to reassign the keyboard interactively, or assign macros to your choice of keys. Sets of these key macros can be saved and re-loaded from disk. Unfortunately, this feature is available in interactive use only--you can't redefine keys under program control. For editing and program creation, though, it can be a useful tool.

There are new string operators, and new ways of accessing strings. For instance, the expression F\$(5:7) specifies the fifth, sixth, and seventh characters of F\$. Assignments can be made to the substrings too, and don't need to be the same length as the substring they are replacing. For example:

Let F\$ = "A short sample."

Let F\$(3:7) = "very long"

would leave F\$ = "A very long sample." Of course, such powerful string operations would be almost useless if strings were limited to only

255 characters. Like AmigaBASIC, *True BASIC* strings can be up to 32,000 characters in length.

Those who have used trigonometric math functions (sine, cosine, etc.) in Microsoft BASIC have discovered (sometimes to their dismay) that results are returned as radians, not degrees. In *True BASIC*, working with degree measurements is as simple as declaring *Option Angle Degrees* at the start of your program. For versatility, there are also functions to convert radians to degrees and back.

All math functions work on double-precision floating-point numbers. (In fact, *True BASIC* has no provisions for using single-precision numbers at all.) There are a lot of these functions built into the language; combined with the speed of the compiled code, it is enough to finally make BASIC a viable language for number crunching.

## GRAPHICS

Default graphics coordinates range from zero to one both horizontally and vertically. By changing these values with the Set Window command, the screen window can show any part of a graph or plot. All graphics coordinates are then clipped to the screen's value range, eliminating the need for the programmer to scale graphics to a specific screen size. The available commands range from setting points to drawing circles to graphing the contents of an array, and their use and parameters are consistent. As a consequence of all this attention to detail, it is very easy to program graphics, and the resulting programs are easy to read and understand.

## SPEED

To compare *True BASIC*'s speed to that of AmigaBASIC, two benchmarks popularized by BYTE were used: the Sieve, which finds the first 1651 primes; and a program called Calculations that tests, not surprisingly, the speed at which calculations are performed. To make things even, DEFDBL A-Z statements were placed at the start of both programs for the AmigaBASIC versions. Each program was run three times, then the times were averaged. See Table One for the results. As you can see, *True BASIC* fared quite well.

## 3-D LIBRARY and DEV. TOOLKIT

It is good programming practice to write libraries of tested routines that can be used over and over. *True BASIC* uses a LIBRARY

*True*  
**BASIC**™  
inc.

statement to reference a collection of such routines. In addition, whole add-on libraries are available. For this review, the *True BASIC* compiler itself was accompanied by both the *3-Dimensional Graphics* and *Developer's Toolkit* libraries. Both packages contain not only object, but source code to all the routines.

The *3-Dimensional Graphics* library has functions to plot points and lines in three-space, in parallel or perspective projections. Additionally, there are subroutines to draw axes, planes, spheres, and even whole functions of the form  $z=f(x,y)$ . This can make seeing what a particular function looks like as easy as entering it and running the program--sometimes. Auto-scaling isn't done by the subroutines, so you have to figure out the boundaries of the plot by yourself. Still, this is the kind of thing a calculus student would kill for. Everything considered, this library is a necessity if you have any mathematical interest whatsoever. The source code is there, too, so it's easy to modify and adapt the routines.

The *Developer's Toolkit* library has a variety of subroutines written to access the specific features of the Amiga, like animation, menus, screen dumps, and lower-level system routines. High-quality animation requires access to quite a few of the system features, but it isn't available with these subroutines. There is the option of writing your own subroutines to work with the animation system, but that's a job

Table Of Benchmark Times

Benchmark	AmigaBASIC	True BASIC
Sieve	73.3	9.8
Calculations	22.6	5.8

Programs were run three times, then the elapsed times were averaged. Note that the True BASIC times do not include the time it took to compile the program; this is done the first time a particular program is executed. The Sieve took 2.3 seconds to compile, while the Calculations program took 1.9 seconds. All benchmarks were run on an Amiga 1000 with a 68000 processor (yes, I took out my 68010) and two 3.5-inch disk drives.

better done with C. Using menus with the provided routines is fairly easy, but also limits your choices. In summary, the routines in this library provide easy access to some system features, but severely limit the options in using those features. There are routines to interface with C and 68000 assembly language functions, so it is possible to write specific portions of a program in those languages.

## DOCUMENTATION

Two books are included with *True BASIC*: *True BASIC Reference Manual* (331 pages), a non-computer-specific reference guide; and *True BASIC User's Guide*, (307 pages) which includes both an introduction to the language and details on the Amiga version. The books clearly show their academic background, looking and reading like college-level textbooks. Both have indexes which are generally helpful.

The *User's Guide* is divided into four sections: Novice, Intermediate, Advanced, and Technical. Between them, they do a good job of covering the full range of *True BASIC*'s capabilities, while attempting to keep from overwhelming the beginning user. The *Reference Manual* has a few problems, most stemming from its generic origins; when definite values are given, they are usually for the MS-DOS version, with a note suggesting that you check the *User's Guide* for more specifics. All in all, though, the documentation for this package is quite a bit better than what most companies provide.

Both the *3-Dimensional Graphics* and *Developer's Toolkit* come with short manuals (50 and 35 pages, respectively) that give overviews of the subroutines included in the library. Examples are sparse in both manuals, a major problem when trying to use routines as complex as these can be. In the *True BASIC* system manuals, small example programs are sprinkled liberally throughout the text; but not in these books, where they are needed much more.

## PROBLEMS

When I first ran the compiler on my 68010-equipped Amiga 1000, it crashed immediately. Use of the public domain program *DeciGel* cured the problem, but it is still something to consider. With use of the 68010 increasing among Amiga owners, and the possibility of newer Amigas using the 68010 or 68020 processors, this is not a minor flaw. *True BASIC* (the company) is aware of the problem, and promises to fix it in the next release. However, that release is not slated until early 1988.

Even after extending BASIC this far, there are

some features of other languages that it lacks. Most of the Amiga's operating system was written in C, and makes a lot of use of the C structure (a collection of variables into one convenient agglomeration, like Pascal's RECORD). *True BASIC*, like AmigaBASIC, has no intrinsic method of dealing with structures; this lack necessitates the use of a mishmash of commands to move your variable values into a memory pattern that simulates a structure. This extra code slows down a program and increases its size; it would be much simpler if the ability to use structures was added to the language.

Another factor to consider is that the compiled programs produced by *True BASIC* will not run on their own--they require either the language itself, or the Runtime package, which goes for \$99.95 for non-commercial distribution. To sell compiled, stand-alone programs, a \$350 license is necessary in addition to the Runtime system.

## CONCLUSIONS

Don't buy *True BASIC* to write programs that use the custom hardware and features of the Amiga. It simply is not very good at such things, even with the *Developer's Toolkit*. Buy *True BASIC* if you want to do number crunching without fighting with a FORTRAN compiler; if you want to use its math capabilities and the 3D graphics library for advanced algebra, calculus, or scientific applications; or for developing programs that may be easily ported between the Amiga, Mac, and MS-DOS environments. For these uses, *True BASIC* shines.

True BASIC	\$149.90
Libraries (each)	\$49.95
Runtime System	\$99.95
Runtime System & License	\$350.00



### ABOUT THE AUTHOR:

Warren Block has been working with an assortment of mini and microcomputers since 1979. He studied math and photography in college, but quit to become a freelance writer and consultant. He lives in Rapid City, South Dakota, near the foot of Mount Rushmore.

# PART ONE

# AMIGA WORDPROCESSORS

by Peggy Herrington

You don't need statistics to know that processing words is the most popular computer application around. And judging from the number of wordprocessors available for the Amiga (so many, in fact, that this is a two-part report) you're probably trying to sort one from the next. Well, don't slink ignorantly into the software store with the flattened air of a cat visiting the vet; give your situation some thought, review the programs covered here (and next time in Part II), and roar in there like a knowledgeable lion!

## PICKING A WORDPROCESSOR

First, consider the kinds of documents you'll be producing. Are you just planning on writing an occasional letter, or will your kids be doing school reports with the wordprocessor you bring home? If so, what about footnotes and outlines? Do you want to illustrate your text, maybe with fancy fonts, or are you about to tackle a book or a thesis with an index and table of contents? Maybe you need an online spelling checker or a thesaurus, and what about columns of text -- newspaper or script style? How about columns of numbers? Do you want totals computed by the wordprocessor or would you rather incorporate statistical data from a spreadsheet? Whatever you have in mind, how often will you use this processor of words? Will it be often enough that you'll be able to remember commands from session to session, or will you need a wordprocessor you can pick up and use once in a blue moon?

You can't do all of these things with a single program, of course, but careful evaluation of your needs will probably reveal one with a balance of power (read: complexity) that won't overwhelm you. You can avoid being overwhelmed by *not* buying a wordprocessor that has everything you could ever possibly need, but remembering that techniques can be used in ways that aren't always obvious. For example, most people think they'll never do personalized form letters (mail merge) only to realize too late that the technique can come in mighty handy for a family Christmas letter. Speaking of which...

## PROWRITE

If the idea of surrounding colorful graphics with equally colorful text appeals to you, *ProWrite* is the only game in Amigatown. I did

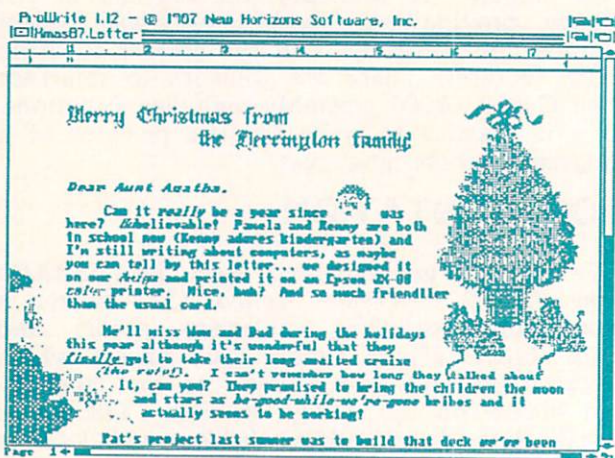

the Christmas letter shown here with graphics imported from Electronic Arts' *Seasons & Holidays Deluxe Library*, typing and arranging the body of the letter only once and adding personal salutations individually since *ProWrite* doesn't have mail merge.

That's not a fatal flaw. *ProWrite* has a Macintosh-like user interface that makes it easy to enter text and import IFF graphics. You type using plain, bold, italic or underlined fonts in seven colors (black, red, yellow, green, two shades of blue and hot pink) placing words around, beside and even on top of IFF images, all of which can be rearranged to your heart's content. Sub- and superscripts are available and margins and tabs are set with an on screen ruler in inches or centimeters. Documents too large for the screen may be viewed with the scroll bars. Text can be justified or centered and aligned with right or left margins. Although it has some desktop publishing features, *ProWrite* is not page layout software as you can't do columns, draw borders (although you can import them) or pour text around images. You *can* work in medium (640 x 200) or high (640 x 400) screen resolution by using the appropriate module. Hi-res gives an accurate representation (WYSIWYG or What-You-See-Is-What-You-Get) of what you'll end up with on paper, including headers, footers and page numbers. While that's great for layout, it's tough on the old eye balls, so plan on installing an anti-flicker screen or wearing Polaroid sun glasses if you use hi-res much. Also plan on expanding Amiga memory beyond the 512K bytes *ProWrite* requires if you want to do much of anything in hi-res.

*ProWrite* will cut, copy, paste and erase text and illustrations, and find and replace text. It



ProWrite \$124.95  
New Horizons Software  
P.O. Box 43167  
Austin TX 78745

INFO-rated



Nice specialty for colorful graphics with fancy fonts in seven colors. WYSIWYG in high resolution but no columns, borders, math or spell checker. Screen colors are fixed so use a screen covering to reduce flicker and expansion RAM for multiple pages with graphics. Non-WYSIWYG medium res module in V1.12. Text files must have associated icons to be recognized. Preference printers, no copy protection. -PH

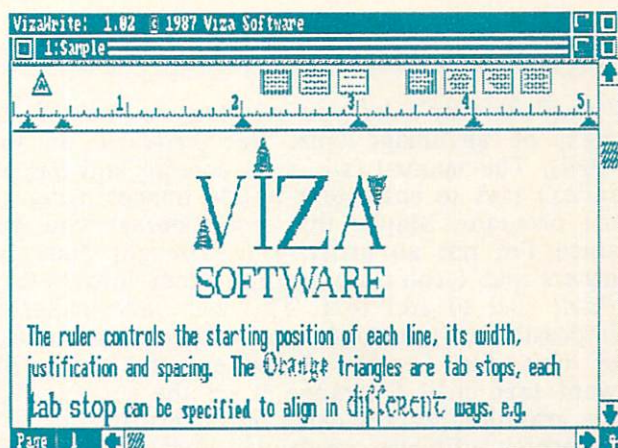

takes advantage of the mouse and pulldown menus and has oodles of alternate keyboard combinations. (When my hands are already on the keyboard I don't like being forced to grope for the mouse.) The 64-page manual is readable and has an index. The program itself is fairly easy -- if slow -- to operate. Loading fonts takes forever and even without graphics, screen refresh isn't swift. A moderately fast typist (me) can outtype it and I'm irked that it loads text files only if they have associated icons (.info files). Files from *Flow*, New Horizon's outline processor (which has recently been nicely upgraded) are compatible and *ProWrite* will output files in ASCII without graphics. It prints through Preferences in standard, NLQ and draft modes. My Christmas letters were done on an Epson JX-80 color printer but I've seen better results from a Xerox 4020. While *ProWrite* is not of professional calibre, I think it's well-suited for occasional use and a necessity if you own a color printer and over 512K of RAM.

## DESKTOP VIZAWRITE

Although it has potential, this "wordprocessor with desktop publishing features" (as it is billed by Progressive Peripherals), is a bit pretentious. *VizaWrite* lets you enter text with different disk-based fonts and import IFF graphics, but as far as desktop publishing goes, *VizaWrite* won't handle columns or borders, both of which are central to the concept. As a wordprocessor, it is slow to work with and low on standard features, like a spelling checker, for instance.

*VizaWrite* is WYSIWYG and lets you open windows simultaneously (depending on memory) in either medium or high resolution. Icons along the top are for justification and line spacing, and a hideable onscreen ruler is for setting margins and tabs via mouse-clicks. Once you learn them, keyboard combinations make selecting words, lines, sentences and paragraphs for cut, copy and paste procedures easy, along with changing fonts in mid-line. It has super-

and subscripts, mail merge and supports user-definable paper sizes.

*VizaWrite* offers password protection and an optional file history so you can see who did what when, along with a detailed report on the number of characters, words and paragraphs in a document. You can build glossaries or libraries of frequently used text and images and insert them where needed. Things like logos, names and addresses, letter headings and even entire paragraphs can be saved separately and inserted from these glossaries.

Besides constantly outtyping *VizaWrite*'s text editor and filing my nails during screen rewrites, I'm not overly fond of its non-standard requesters or the fact that you can't scroll through file names with the cursor keys, although double-clicking the mouse button will load them into memory.

This wordprocessor (v1.03) currently exhibits some very odd quirks, oversights, and bugs, like screen display garbage problems, a single-page

Desktop VizaWrite \$149.95

Progressive Peripherals  
& Software  
464 Kalamath Street  
Denver CO 80204

INFO-rated



Over-billed as a "desktop publishing" wordprocessor, v1.03 mixes fancy disk-based fonts (plain, bold, italic, or underline) with IFF graphics (monochrome only). WYSIWYG with mail merge but no columns, borders, or spell checker, it's overly ambitious, bug-ridden, and clumsy to use. Very limited graphics capabilities, and uses non-standard file requesters. Medium (on 256K) or high resolution displays. -PH

print option that instead prints all pages, and it lacks an overtyping mode. *VizaWrite* loads colored graphics as solid silhouettes, making them virtually unrecognizable. You have to first differentiate colors with pattern fills in an art program. But its biggest graphics-related problem is that no matter how small they are,

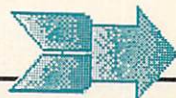

*VizaWrite* won't let you put text to the left or right of an image (just like *geoWrite* on the C64!). The manual (which is concise and has an index) says to enter text beside images using an art program. Maybe this won't bother you but since I'm not an artist, I use images done by others and I can't see loading them into *Deluxe Paint* just to add text. This not only makes it impossible to put borders around pages or blocks of text, but I never know exactly where I'll want text until I arrange it on the screen with the graphics, so how can I do it beforehand?

Despite glitches, multiple bugs, and user-interface problems, *VizaWrite* does a better job of printing than I thought it would, with custom support for nine popular printers as well as any Preference printer. It does a good job with graphics fonts, including Zuma's, Calligrapher's and those I tried from the public domain, and you can optionally print using your printer's built-in fonts, if you prefer.

We talked to Progressive about some of *Vizawrite's* problems, and they indicated that they weren't happy with it yet, either--they promise registered owners free upgrades, with multiple columns and improved program response as top priorities.

## LPD WRITER

Personally, I won't buy productivity software with disk-based copy protection and because of that, Digital Solutions will not be pleased with this report. For an additional fee, you can buy an extra copy of *LPD Writer* but -- because it, too is copy protected -- you cannot make a backup copy or run it from a hard disk. Also thanks to copy protection, *LPD Writer* will run only from the internal disk drive which limits multitasking.

*LPD Writer* is a straight wordprocessor. It is the first of an integrated series of programs including a spreadsheet and database that will be produced by Digital Solutions in the near future and offer file compatibility. Like *VizaWrite*, *LPD Writer* will run on a 256K Amiga but it won't operate in high resolution without 512K. There's a spelling checker which I didn't have a chance to actually test (see below for why), mail merge, and the screen display is mostly WYSIWYG showing multiple-line footers and headers with page breaks. It won't do columns, footnotes or, of course, graphics.

*LPD Writer* is extremely flexible to operate. Pull down menus can be used with the mouse or you can alternately use the function keys which are organized in a similar manner. They correspond to the pull downs, and pressing one changes the commands available on them (which

LPD Writer \$119.95  
Digital Solutions  
P.O. Box 345, Station A  
30 Wertheim Ct. Unit 2  
Richmond Hill ON L4B 1B9

INFO-rated



Text only with a single screen font in plain, bold, underlined or italics, no columns, graphics or math. Flexible user-interface with spell checker and mail merge but miserable disk-based copy protection. Runs on 256K and will have file compatibility with LPD spreadsheet and database programs when available. Preference printers.

- PH

are shown in a menu along the bottom of the screen). You can move rapidly through the text by word, line, sentence, paragraph, etc., using cursor, shift, and Alt key combinations. Other keyboard combinations are supplied and you can pick how you want to do things using all methods. It displays a single onscreen font in standard Amiga styles and saves files in a proprietary format or IFF (which doesn't save font styles, line, tabs, paragraph or margin info).

The 90-page manual is written in the first person by Karl Hildon of *Transactor Magazine*. It includes tutorials and is light, entertaining and complete with exception of an index, although the table of contents is very detailed. I'd like to tell you more about *LPD Writer* and show you a screen or two but, after the third or fourth time I used it, something went wrong with the copy protection and it now refuses to load. I reported that to Digital Solutions but, as we go to press, I have yet to receive a replacement.

## SCRIBBLE!

Speaking of straight wordprocessors, you haven't had an Amiga long if you haven't heard about *Scribble!*. This straight-forward program is utilitarian and easy to grasp, which is exactly what thousands of Amigans have done with it. *Scribble!* uses the default screen font in plain, bold, italic and underline styles, although you can access your printer's fonts and features with escape codes if yours isn't a Preferences-addressed model. It isn't fancy as it doesn't do

Scribble! \$99.95  
Brown-Wagh Publishing  
16795 Lark Ave., #210  
Los Gatos CA 95030

INFO-rated



Still the best casual, general purpose Amiga wordprocessor around. Uses standard plain, bold, underlined and italic onscreen font. Has mail merge and spelling checker but doesn't do graphics or columns. Preview mode and trick allows multitasking during printing. Preference printers, not copy protected.

-PH

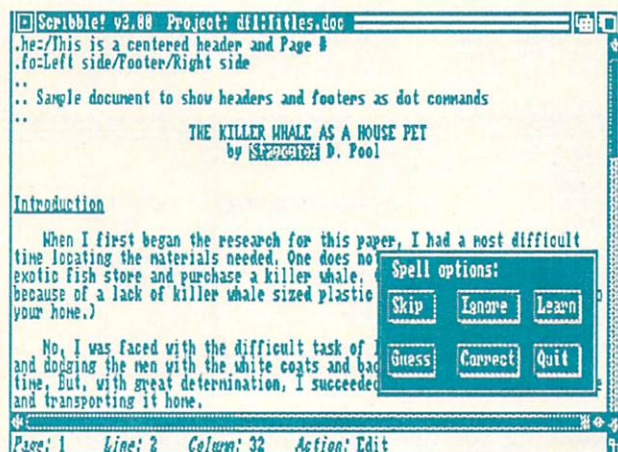

columns, math or graphics. Some features are available on the function keys and pulldown menus (justification, line length, page size, etc.) but *Scribble!* would benefit from more keyboard command shortcuts as far as I'm concerned. Since most text formatting is done with embedded commands there's a separate preview mode to let you see the layout of your document before you print it. *Scribble!* has mail merge and a built-in spelling checker and text can be transferred between windows with the mouse. As far as glitches go, the only one that really gets me is that file requesters don't show directory names or file size.

*Scribble!* will multitask but unless you know an undocumented trick, it takes over the system while it prints: Type or load your document but before you start printing, run any tiny (so you won't run out of memory) background program that will let you switch between programs with left Amiga-M and N key combinations rather than the corner gadgets. Only certain programs do this, but with this ability you won't have to disturb the sleeping pointer while it's on the *Scribble!* screen. Run the other program and flip back to *Scribble!* with left Amiga-N. After printing has started, switch back to the second program with left Amiga-M -- NOT the corner gadget. The pointer will still be asleep but you can click it back to life on this second screen without halting printing and continue using your Amiga, either there or in a second *Scribble!* window if (memory permitting) you opened one before you began printing. Until it's finished, approach and leave the printing *Scribble!* window with Amiga key combos rather than the gadgets.

Because *Scribble!* doesn't have a lot of sophistication, if you have any wordprocessing exposure, you can write with it out of the box, learning (from the well-written manual) its more advanced features as you need them, features

like hanging indents, block transfers and global search and replace. If you produce letters and simple reports, and even if you write magazine articles or modem text uploads, you could do a lot worse than *Scribble!*.

## WORDPERFECT

IBM *WordPerfect* has been a bestseller for years and books are *still* being written about it, but the Amiga version has a way of polarizing users -- you love it or hate it. Buy *WordPerfect* only if you are dead serious about words. Although it is fully Intuition-based with mouse and pull-down menus, it is not pretty. It isn't WYSIWYG and doesn't do fonts or graphics but if you want a no-nonsense text-based power-horse this is it.

Like it or not, Amiga *WordPerfect* is very IBM-like; it is number and text-based even to the file requesters although you can select options from

WordPerfect \$395.00	<b>INFO-rated</b>
WordPerfect Corporation 288 West Center Street Orem UT 84057 801/227-4000	★★★★
This power-house does everything but graphics and disk-based fonts: includes speller and thesaurus, columns, math operators, ASCII line-drawings and mail merge but no sort. Not WYSIWYG. 250 printer drivers with configuration program. V4.1's tutorial, elaborate manual and macros greatly reduce complexity of operation. Intuition-based with pulldown menus but MS-DOS look and feel. No copy protection.	
-PH	

requesters and pulldown menus with the mouse. Alternately, everything can be done from the keyboard using the numerical keypad and the function keys, for which four commands are available from each (pressed alone or with Ctrl, Alt or shift keys). *WordPerfect* uses its own screen font in plain, bold, italics or underlined styles and these, along with page breaks and columns, are about the extent of what's shown on the screen. Although it accommodates them, it doesn't show headers, footers or footnotes. Invisible embedded formatting codes are used which can be seen and deleted from a partial "reveal codes" screen.

As far as manipulation of text and numbers goes, what *WordPerfect* doesn't process might not be worth doing. It provides automatic outline numbering and indentation, index and table of contents generation, multiple-line headers and footers, binding margins, numbered footnotes and endnotes, automatic alignment of columns of numbers with four-function math

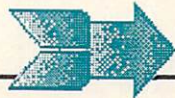

operators and an admittedly slow 115,000 word spelling checker and thesaurus for synonyms and antonyms. You can arrange up to five columns of text in newsprint style (script style is available too) and transfer text between windows while multitasking, the latter provided you set the program up properly and have expansion RAM. Also offered are mail merge (alas, without a sort) and extensive block operations for cut, copy, paste, delete, search and replace. Files can't be chained but file size is limited only to available disk space (including a hard disk) and around 250 special printer drivers are provided along with an unbelievably elaborate configuration program for addressing others.

And how is all this to use? Don't kid yourself, kiddo, power like this won't be yours in a day. There's great online help from the Amiga's HELP key and the splendid 600-page manual includes an extensive tutorial coordinated with on-disk documents you can spend days studying. If you don't have days to invest, *WordPerfect's* macros can save them for you. Macros dramatically enhance this plethora of features without requiring rote memorization. You see, anything *WordPerfect* can do can be programmed to happen in sequence with a macro, which not only eliminates repetitious keystrokes and assures accuracy, but means you don't have to remember a zillion commands -- just learn how to use macros. Take writing letters: You can program a macro to come to life as you start the program and have it type your usual heading (perhaps bold-faced and underlined), skip down and enter the current date (read from the Amiga) and leave the cursor in place for you to type the name, address and salutation. After you've written the letter, you can have another macro enter a closing paragraph and skip down and type your name. But that's not all; that same macro can be set up to go back to the top of the letter and down so many lines to retrieve the recipient's name and address and then automatically switch the program to the built-in envelope or mailing label print routine. If you don't have pre-printed return envelopes it can also include your return address so that all you have to do is engage your printer and tell *WordPerfect* to hit it.

The program itself resides on Workbench window(s) and I think it would benefit from being on its own screen. That would make screen refresh and scrolling faster (isn't anyone ever gonna do a smooth-scrolling wordprocessor?) and let you flip between program screens with Amiga/M and N when multitasking. *WordPerfect* demands disk

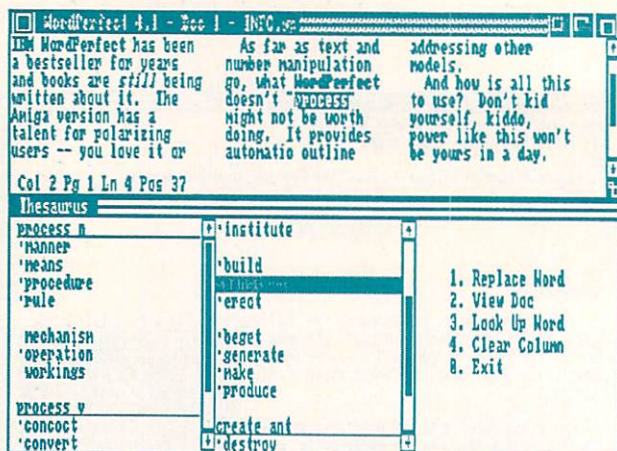

switching for the speller and thesaurus on a two drive system but it operates beautifully from a hard disk and the upgrade policy for registered owners and educational discounts are major advantages.

## P.S.

It isn't perfect but *WordPerfect* is the most professional application reviewed here, and although I use *ProWrite* for color and *Scribble!* for quickies, it is the wordprocessor of my choice as I write this. However, remember that I'm a professional writer; I write all the time, and you may not need its complexity. And I wouldn't be worth my weight in words if I didn't reserve the right to change my mind in the next issue -- there's still lots of room for improvement. By then, I hope to have my hands on Commodore's *Textcraft Plus* (which we'll compare with cutsey *Textcraft*), *MicroIllusions'* *Dynamic Word*, *DesignTech's DesignText*, *Redact* from Vertex Corporation, *Write&File* from Brown-Wagh and Abacus' *Becker*. I'm hoping at least one of them offers the lion's power of *WordPerfect* with the feline grace of the Amiga. And who knows? Maybe we'll have info on Commodore's new Preference printer drivers then, too. PostScript, anyone?



### ABOUT THE AUTHOR:

Peggy Herrington is a well-known freelance writer in both the Commodore computing and music fields. She got her bachelor's degree ("in music history, English, computer science, and a smattering of other things", according to Peg) from the University of New Mexico, and works out of her home MIDI studio in Albuquerque, surrounded by Commodore computers, synthesizers, kids, and an occasional lizard.

## REASON

*Reason* isn't a wordprocessor. It is a language and style checking program that compares your text files against standards set by managers at Bell Labs. It's based on *Writers Workbench* for IBM-compatibles from AT&T. *Reason* gives your text a thorough working over, reporting its analysis of your word usage and writing style. It only suggests changes, leaving you the option to make them or not.

I analyzed the accompanying wordprocessing article with *Reason* before submitting it for publication. *Reason* predicted it could be read by someone with 11 or more years of schooling, a good score for instructional documents. It further reported that I had 17% compound sentences and 21% compound-complex, a total of 38%, and told me most good documents of this type have a combined percentage between 5% and 26%.

It suggested breaking up the compound-complex sentences (which it offered to list) noting that would also help reduce my average sentence length of 22 words. A good average, it claimed, would be 15 to 20. And it nailed me for a 59-word sentence, claiming that a columnar listing would be easier to follow. It reported I appropriately limited passives and nominalizations, that I had no sexist phrases or incomplete sets of quotation marks and parentheses. It said I used 99 abstract words which represented only 2% of the total word count, gave me a list of possible misspelled words, and listed words used repeatedly. *Reason* also produced the short-hand sort of overall analysis in the accompanying chart.

*Reason* can't check words in context so you should consider its diction analysis carefully. It advised striking words like "definitely", "fairly", "in fact", "quite", "relatively" and "very" from my

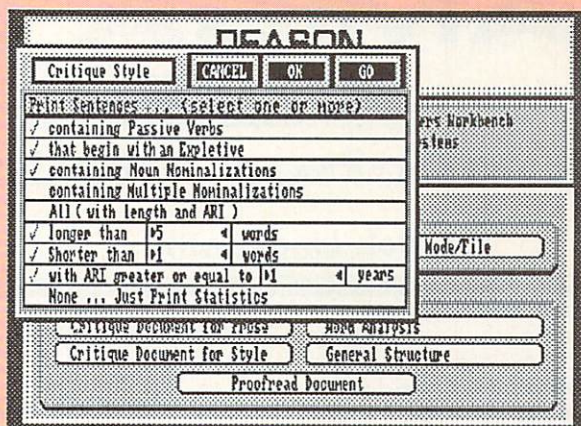

text, and although I realize those can be weak words, when I used them, I did so with reason (you should pardon the pun) so I didn't follow its advice. Each time I used "which" it told me to replace it with "that" when the clause was restrictive.

But it didn't explain what a restrictive clause is because it's not an English teacher. *Reason* simply provides a critique in a less threatening way than that by a real person, which is one of the reasons for its success within educational systems--a newspaper article I read recently which stated that its forerunner routinely raises students' grades a letter or more when used faithfully.

You can personalize *Reason* by building custom dictionaries and inserting criteria against which your documents will be compared. It isn't an Amigatized program; it won't multitask and doesn't have pulldown menus, everything being accomplished by clicking the pointer on icons and requesters. But if you have the budget and application for it, I think *Reason* will serve you well.

### REASON'S ANALYSIS OF PEGGY'S WORDPROCESSING ARTICLE

#### Readability grades:

(Kincaid)=11.3  
(auto)=11.8  
(Coleman-Liau)=10.3  
(Flesch)= 11.1  
(54.4)

#### Sentence info:

no. sent=160  
no. wds=3606  
av sent leng=22.5  
av word leng=4.66  
no. questions=12  
no. imperatives=3  
no. content wds=2159  
59.9% av leng 5.78  
short sent (<18) 38% (61)

long sent (>33) 17% (27)  
longest sent 59 wds at sent 90  
shortest sent 2 wds at sent 36

#### Sentence types:

simple 27% (44)  
complex 34% (55)  
compound 17% (28)  
compound-complex 21% (33)

#### Word usage: verb types as % of total

to be 30% (114)  
aux 27% (106)  
inf 11% (41)  
passives as % of non-inf verbs 11% (37)  
types as % of total prep 9.0% (323)  
conj 6.4% (231)  
adv 5.2% (186)  
noun 26.7% (961)

adj 19.2% (694)  
pron 7.6% (273)  
nominalizations 1% (48)

#### Sentence beginnings:

subject opener:  
noun (33)  
pron (25)  
pos (1)  
adj (33)  
art (6)  
tot 61%  
prep 5% (8)  
adv 9% (15)  
verb 6% (10)  
sub/conj 11% (18)  
conj 4% (6)  
expletives 3% (5)



# AMIGA DESKTOP PUBLISHING

## Publisher 1000 & PageSetter

by Bob Lindstrom

Pagesetter \$149.95 Gold Disk P.O. Box 789, Streetsville Mississauga, Ontario Canada L5M 2C2 416-828-0913	<b>INFO-rated</b> ★★★
--	--------------------------

A medium-level desktop publishing program aimed at the dot-matrix newsletter crowd. A well-designed interface seemingly inspired by DeluxePaint makes the program relatively easy to use. However, a lack of features and the inability to edit text within the page layout make the program less flexible than it could be. -BL

Publisher 1000 Brown-Wagh Publishing 16795 Lark Ave., Suite 210 Los Gatos, CA 95030 800-451-0900	<b>INFO-rated</b> ★★★
--	--------------------------

This entry-level desktop publishing package produces attractive dot-matrix output due to a superior custom set of character fonts. Text editing within the page layout makes error-correction efficient. A screen display that only shows a portion of the page, though, creates unusual difficulty in overall page design. A brave first effort in Amiga desktop publishing but too limited to be satisfactory. -BL

### THE FIRST WAVE

Although the popularity of the personal computer was secured and blessed by the holy trinity of computer software - word processor, spreadsheet and database - desktop publishing has surpassed them to become the glamor application of the 1980s. But in some cases, the enthusiasm has gotten out of hand.

Computer software publishers with hope in their hearts and currency symbols in their eyes long to enter the lucrative desktop publishing sweepstakes. The more obnoxious of them sputter platitudes about how pamphleteering made this country great. (If Thomas Paine only had owned a Macintosh when he wrote "Common Sense" the American Revolution could have taken place in a 32 point Geneva.)

Others imagine a rose-colored future in which every man and Everyman have the resources to print and distribute his own newsletter or books. Now, *there's* a scenario worthy of Stephen King: a world overrun by amateur publishers. Imagine windswept back issues of *The Hulk Hogan Manifesto* littering an abandoned Times Square, or motel bedsides graced with Free (Take One) copies of "My Mother The Car: Sitcom or Religious Sect?"

Seriously, though, desktop publishing has proven in many cases to be an invaluable asset. Whether you're putting out an Elks Club newsletter, an industrial document, an advertising layout or just writing the annual Christmas card insert, the results will look better with the help of a computer, a dot-matrix or laser printer and the appropriate desktop publishing software.

Although the Apple Macintosh and Aldus'

*Pagemaker* software are widely regarded as the industry standards in desktop publishing, the Commodore Amiga could shape up as an outstanding computer for the purpose. It ought to be a desktop publishing natural with its superior potential for fonts and graphics combined with computing power unsurpassed among affordable micros.

However, the Amiga can't do it alone. It needs software and, at present, the situation is sincere but not serious. The first two Amiga desktop publishing programs - Gold Disk's *PageSetter* and Northeast Software Group's *Publisher 1000* - are promising introductions to the future of Amiga page layout and printing; but they don't yet deliver the highest quality output or the ultimate in computer-aided publishing techniques.

### WHAT DO THEY DO?

The jargon of desktop publishing - points, picas, rules, fonts, typefaces, kerning, microjustification - can make the process seem complex, arcane or just plain confusing. But when the ink meets the page, it's quite simple. The point is to artistically arrange boxes on a page, attractively fill those boxes with text or pictures, and print the results in a polished and professional presentation. That's it.

Because the means and the ends are so basic, most desktop publishing programs work very much alike. The differences are in the flexibility of the tools and the program's skill at refining the appearance of the text.

*PageSetter* and *Publisher 1000* work in comparable ways. In each, you begin with a model of a blank page. You use the mouse to

draw and position boxes or columns on that "blank page" (like creating a rectangle in DeluxePaint). A cursor location display shows your current position on the page in inches or picas (one-sixth of an inch). (*Publisher 1000* can also measure in millimeters.) Using this X/Y coordinate system along with onscreen rulers, you can precisely align the boxes.

When the general structure of the page has been designed and all the boxes have been placed or "pasted-up", you fill those empty spaces with text and graphics loaded from disk. If a text block is too large to be contained in a single box and you want it to continue in other boxes or, perhaps, on another page, the program has a way to link boxes. Any text begun in the first box will overflow into succeeding linked boxes.

At various points in the process, you have the opportunity to customize the look of the page by choosing from a wide variety of fonts, by selecting various types of text justification (flush left, flush right, center or full justification), and by sizing and cropping the artwork.

Documents can be created a page at a time or you can produce multi-page pamphlets and newsletters, subject to the available memory of your Amiga. If you're involved in serious and sizeable projects, two megabytes or more of random access memory (RAM) are highly recommended.

## SO WHAT'S THE DIFFERENCE?

The fundamental difference between *PageSetter* and *Publisher 1000* is the way each lets you interact with your model page.

*PageSetter*, which works properly only in medium-resolution, provides three levels of magnification that allow you to view a whole page, two-thirds of a page or one-quarter of a page at once. At any time in any magnification, you may create and resize text or graphics boxes, fill them, or move them around the page. Although it is possible to alter the justification of any individual text box, it is not possible to edit text that already has been flowed into the boxes.

In order to massage text before pasting it up, *PageSetter* provides a medium-function, integrated text editor. Text files from Scribble! and TextCraft can be loaded into this editor and retain their original type styles (bold, underline, etc.). Ordinary ASCII texts may also be used. All text must be loaded into this editor before it is transferred into a text box. The only exception is a QuickText single-line requester/editor used primarily to directly enter

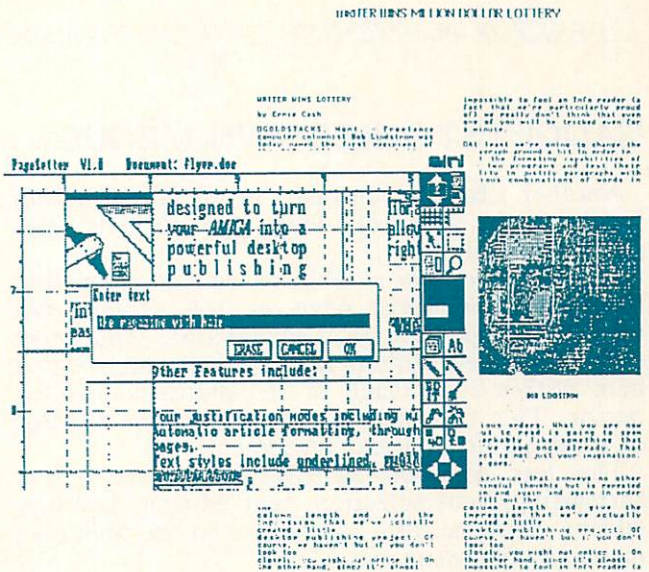

*PageSetter* screen and an actual finished page.

column headings, inset quotes or place headlines into their own text boxes.

*Publisher 1000* has taken the opposite route - full text editing at a single level of magnification. The page is always displayed at full magnification leaving only a part of the screen visible at any one time (one-fourth in high-resolution and one-eighth in medium-resolution). Scroll bars are used to move around the document.

The benefit here is that once a text box is filled, the user freely may add, delete or rework pasted-up text. It is possible to type words directly into an empty box. The trade-off is that the entire page is visible only in a preview mode. The mode shows a graphic representation of the entire page on the screen but it may not be manipulated in any way. It's a pretty picture (and sometimes helpful) but otherwise untouchable.

Only the most cerebral paste-up artist will be able to form a solid mental image of his page using this awkward scroll and preview process. Commodore 64 owners may remember using word processors that purported to give 80-column displays by moving the text across the 40-column screen display. Yes, friends, it is just as irritating on the Amiga as it was on the C64!

As an additional drawback, I found the text editing (Type) mode somewhat erratic. Positioning the cursor within the text and deleting characters sometimes produced the desired result and at other times skipped lines or inserted an unwanted character.

For basic page design, *PageSetter's* accessible and useful magnification modes provide the user with a much more flexible What-If? environment in which to play with various page formats.

## GADGETS? PULLDOWN MENUS?

Another basic contrast in each program involves the use of icons or gadgets and pulldown menus.

*PageSetter* offers a table of gadget icons that sits along the right edge of the screen, not unlike the gadgets in *DeluxePaint*. The most commonly used options in *PageSetter* are located here within easy reach of the mouse-controlled cursor. This fast accessibility speeds the process of page design and text placement.

The less common *PageSetter* options - box formatting, font selection, text editing, graphics editing and the like - are placed in pulldown menus in the menu bar.

This arrangement worked efficiently with a minimum of mouse muscling. Typically, the icon commands will suffice during the fine-tuning of a page design. You'll move to the menu bar only at decisive moments (such as filling boxes or changing fonts).

*Publisher 1000* is driven entirely by pulldown menus. As a result, the user constantly is pushing mouse from text to bar and back. The result is lots of wasted motion (not to mention the perpetual manipulation of those screen positioning bars as you move from one part of the page to another).

## HOW DOES IT LOOK?

Though the *PageSetter* software design clearly is the easier to use, *Publisher 1000* takes the visual prize, hands down.

Any desktop publishing program has to face a showdown with the Amiga fonts. They aren't going to win any design prizes. They tend to be blocky, jaggy and irregular, particularly when sent to a dot-matrix printer.

Northeast has designed a group of fonts that look wonderful when dot-matrix printed. Clean, smooth, attractive - their elegance restored my faith in the potential of Amiga fonts. Anything printed using these lovely fonts is going to look better than a document prepared with the standard Amiga lettering.

*PageSetter* includes the standard Amiga fonts. Enough said.

Although *PageSetter* contains an integrated graphics editor (a companion to the built-in text editor) that allows you to either manipulate existing IFF-format graphics or to draw entirely new pictures, *Publisher 1000* is much more effective in importing existing IFF graphics. A medium-resolution picture imported to *PageSetter* came out as a grey scale smear.

### WRITER WINS LOTTERY

By Ernie Cash

QUESTIONS: How - France computer columnist Bob Lindstrom was today named the first recipient of the

other that seen its must expense to for an idea reader is fact that were particularly proud of it we really doubt that from one of you will be tracked out for a while.

All right were going to change the program around a bit in order to test the formatting capabilities of the full program and that four ways to easily integrate with other applications, to work in various resolutions, to work in various colors, that you are now read to read is going to seem remarkably we

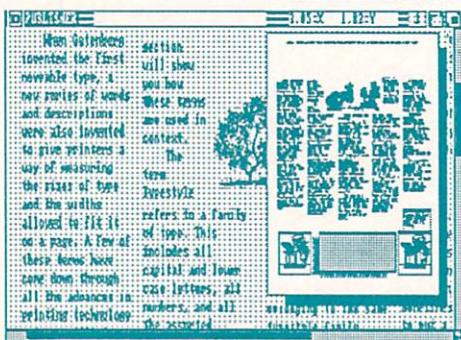

The little window with it makes the thing, an other meaningful thought, but is repeated again and again in order to fit out the column length and give the expression that we've actually created a title.



BOB LINDSTROM

something that you've read once already that effect is not just your imagination here guys.

A sentence that comes to other meaningful thoughts, but is repeated again and again in order to fit out the column length and give the expression that we've actually created a title. Of course we haven't but if you don't see too clearly, you might not notice it in the other hand, but it's not really intended to live with another it

### *Publisher 1000* screen and its output.

*Publisher 1000* gracefully reduced it to a crisp black and white image.

However, both programs demand that the user do a little bit-twisting in order to compensate for the difference in proportion between the Amiga screen and most printers. To my taste, this is the kind of issue that computers should worry about and computer users should be allowed to ignore. Poor marks here for both packages.

The final product, produced with an Epson-compatible Panasonic 1091 dot-matrix printer using the Amiga's Epson driver, printed faster and looked better coming from *Publisher 1000*. The superior appearance was due largely to the excellent fonts and the better graphics importing.

Neither program's result had that indefinable sophistication that marks Macintosh/ImageWriter documents; but the results were quite good and show that with a little additional help from the software the Amiga could make the Mac taste like sour apples.

## THE BOTTOM LINE

Each program additionally was full of other assets and liabilities.

Both do kerning (attractively fitting letters together) and make it possible to change leading (spacing) between lines. Neither supports automatic hyphenation. *PageSetter* provides an optional LaserScript disk that contains PostScript fonts for laser printing (which will provide truly impressive final results). Both lack automatic page numbering. *Publisher 1000* has no graphic editor but does incorporate a good pattern editor to create borders and fill patterns. *PageSetter* has a useful graphics editor built in. *PageSetter*



is unprotected. *Publisher 1000* uses a dongle protection scheme (If I get one more dongle ... ARRRGGHHH!). Neither program supports 24-pin printers. Neither will naturally flow text around graphics.

And so it goes. Both programs leave much to be desired.

If it were possible to amalgamate design features, one good quality desktop publishing program could be fashioned from these two programs. At least you can use *Publisher 1000*'s beautiful fonts in *PageSetter*. That's one possible compromise. And you can transform IFF graphics to beautiful black and white with a graphic utility like *Butcher*, import that version to *PageSetter* and achieve much better visual output. Another compromise.

Some of the blame has to be placed on the Amiga and its printer handling. The Amiga's solution to printer/program compatibility is flexible and ingenious: to have machine-specific printer drivers that enable programmers to use machine-independent Amiga print routines. However, the system is handicapped by slow and generally unsatisfactory printer drivers. And the Amiga system fonts are also less than ideal. Inevitably, these warts are going to mar the features of any desktop publishing package that does not step forward with its own set of solutions. It is no accident that *WordPerfect* for the Amiga contains custom *WordPerfect* printer drivers or that Electronic Arts' new *DeluxeWrite* and *DeluxePrint II* will also have EA-written print drivers.

Apple's Macintosh continues to reign in the kingdom of desktop publishing. However, *PageSetter*'s successor, *Professional Page*, will upgrade the agreeable *PageSetter* design into a much-improved program and the Amiga into a much-improved printing companion. At present, Amiga desktop publishers must be satisfied with a series of compromises all of which point to a tantalizing future of publishing potential.



#### ABOUT THE AUTHOR:

After spending years as a classical music critic for a Major Metropolitan Newspaper, Bob Lindstrom became a free-lance writer in the computer and music fields. His credits include regular columns in the highly respected Apple magazine A+, and in some Scandinavian Commodore magazine whose name I can't spell or pronounce.

# THE MAKING OF INFO

As most of you already know, we create every issue of *INFO* using only Commodore computers and commercially available third-party products. We don't want to just *talk* about what can be done with these fine machines--we want to *show* you! Over the years, we've had hundreds of letters asking what products we use and how we use them to get the results we do. Well, we're finally going to give in and divulge some of our secrets! This new column will fill you in on the tools we use to create *INFO*.

Since issue #1, the text for *INFO* has been produced using a variety of C64 and C128 wordprocessors. The output has been sent to many different dot-matrix, daisywheel, and laser printers. Our current combination (and the one we've used since issue #10) is a C128 running *Vizawrite Classic* driving a *Hewlett-Packard LaserJet Plus* printer.

We use *Vizawrite 128* for several reasons. First and foremost, it supports the HP laser printer. This gives us much better output than a dot-matrix or daisywheel printer ever could. It also does justification, supports the laser's built-in fonts, does a wordcount, and shows us on-screen how the columns will break. It gives us immediate feedback on how many pages we're filling, and how much we have to pay the writers!

*Vizawrite* also supports parallel printing through the user port via a custom parallel cable (from Redmond Cables) directly to the HP. This is much faster than standard serial printing, and we don't have to mess with a printer interface.

We picked the HP laser printer because it was supported by both the C128 and the Amiga. We can print hires graphics and text on the same printer. But we still have to paste up the pages by hand, because we generate graphics on the Amiga and text on the C128.

Now that desktop publishing software like *City Desk* and *Professional Page* is here, along with powerful wordprocessing for the Amiga in the form of *WordPerfect*, we expect to be transferring most of the operations to the Amiga by the next issue. But we've been impressed with what we've been able to accomplish with a C128, *Vizawrite*, and the *HP LaserJet+*.

# COMING SOON

by Arby Fuller

...Desktop publishing is just getting off the ground for the Amiga. Several desktop publishing packages are "just round the corner". We'll have full reviews of these products soon, but we thought you'd like a preview of some of their features.

## CITY DESK

In the next *INFO*, Bob Lindstrom will present a full review of this powerful desktop publishing package. We've been playing with version 1.1 of this program for just a few days, and we're already impressed with what it can accomplish. (For a sample of what you can do right out of the box with just a few hours of playing around, take a look at the cover.)

*City Desk* features a multiple-zoom-level view of the pages you're working on, including multiple full-page display. The manipulation tools are in a handy on-screen "toolbox" with right-button-activated popup controls for options, just like *DPaint II*. Additional commands are on pull-down menus, with handy keyboard equivalents for many functions.

Most of the activities are intuitive. Moving graphics and text is quick and easy; editing, cropping, and sizing graphics is uncomplicated; and even reflowing text is a simple task. The text editor is only a single-line "caption & headline" editor, but it's relatively simple to bring up the text editor of your choice in the background. (We've been using *TxE*.)

*City Desk* is the first package we've seen with

full HP LaserJet + and PostScript support, and that's one of the reasons it has made such an impression on us. If you don't support high-resolution built-in laser printer fonts, the Macintosh crowd will laugh you right off the playground. This package does outputs like the big boys, and that makes it the first real pro contender in the Amiga desktop publishing arena.

## PROFESSIONAL PAGE

It's coming. We'll have a copy in our hands in just a few weeks. We can't wait.

It's *Professional Page*, the big brother of Gold Disk's *PageSetter*. If you believe half of what they're promising in their sales and promotional literature, everybody should just toss out their

"All the tools you need to print"

## New Laser Times

VOLE CXXVII No. 2

## MAC ATTACKED

### Amiga Redefines Desktop Publishing

This page was created with revolutionary new software that makes professional desktop publishing far beyond the reach of the black and white Macintosh. Introducing Professional Page from Gold Disk Inc. Priced at US\$95, it's the first product to channel the Amiga's incredible graphics capabilities into a PostScript compatible desktop publishing program for the serious power user.

Graphics make the difference.



SPLASH ON THE COLOR color documents. Even create magazine quality art up to 2400 dpi when in

### THE GOLD DISK SOFTWARE FAMILY

Besides the revolutionary Professional Page software for the power user of desktop publishing, Gold Disk Inc. also offers easy-to-use entry level desktop publishing (*PageSetter 1.0*, \$189.95), with modules that add exciting new operators (*FontSet 1.0*, \$34.95), PostScript laser printer typesetting capabilities (*PageSetter LaserPrinter*, \$44.95), and Hewlett-Packard LaserJet printer interface (*PageSetter*, \$44.95).

In addition, Gold Disk also features a spell checking program, *GoldSpell 2*, with a 6000 word dictionary. It not only suggests correct spelling, but also allows you to create a private dictionary of personal terms for use with your word processing software.

*GoldSpell 2* works with most popular wordprocessors including *TextCraft Plus*, *Scrivener*, *ProWrite* and *VisaWrite*.

### MacAnon Just Say No

Macintosh Anonymous Meeting. There's no reason to be ashamed, millions of

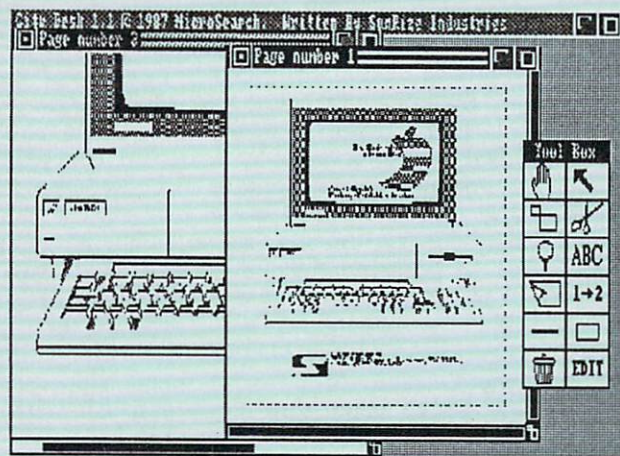

Macs and PCs and professional typesetting equipment now and order an Amiga and a copy of this color desktop publishing package.

What will it do? Well, let's just take a look at their three-page brochure...kerning, auto-hyphenation with user-definable exception tables, fonts from 1 pt. to 127 pts., flowing of text around odd-shaped graphics, leading, 4096 colors, graphics editing, WYSIWYG full-featured wordprocessing, and an optional

module that produces four-color separations, for starters. For output, it supports PostScript, the HP LaserJet +, and professional typesetting equipment. Of course, the program is fully Amiga-tized, with pull-down menus and a "toolbox" menu, and there are all kinds of nice little gadgets and doodads for playing around with the tiniest little details, like the spacing between individual letters.

If this package delivers, it's the software we've been wanting to run on our Commodore computers for a long, long time. Gold Disk bit off a lot when they undertook this project. We have high hopes that *Professional Page* will help the Amiga achieve the respect it deserves.

## SHAKESPEARE

If you like the thought of desktop publishing in all 4096 Amiga colors, **Infinity Software's** *Shakespeare* desktop publishing package should be available by the time you read this. We picked up a beta test copy at the COMDEX show, and we can tell you that it has some very nice features.

Of course, like all preliminary software, our beta version still has some features that aren't implemented yet and some bugs to track down. We will, as usual, refrain from passing judgement on this program until the final version is released.

What we *can* say is that it has a very nice user interface. There is the ubiquitous "toolbox" for placing, modifying, and manipulating graphics and text. Text can be edited on-screen within the text frames, and the editor even includes cut-and-paste functions. Infinity has opted for a screen layout that doesn't show you the full page while you work, though the release version will include a full-page preview. It does feature automatic scrolling if you attempt to move or extend a box out of the displayed area, which saves you some manual scrolling and diddling around time.

The color support is innovative and impressive. To allow you to use *all* the Amiga's colors at one time without going into slower HAM mode, they've used a system that stores the palette for each standard IFF brush graphic frame in memory, and displays the whole screen in the colors of the currently active frame. This gives you "false colors" for the other frames while you work, but allows for printing beaucoup colors on the finished page. Besides IFF graphics files, *Shakespeare* also supports the



Amiga ColorText (tm) font standard for some truly amazing text displays!

You can print an original to any Preferences-supported color graphics or b&w dot-matrix printer. There is no provision for producing color separations (yet), but the ads say there will be PostScript laser support. If Infinity delivers on all their promises in the finished version, *Shakespeare* will hold a unique position in the desktop publishing market.

## THE FUTURE

When you consider that it is only recently that Macintosh desktop publishing programs have offered features like color support and text flow around odd-shaped graphics, it's interesting that we're seeing such features right out of the gate on some of the Amiga products. With the new wave of more powerful inexpensive laser printers, the incredible color capabilities of the Amiga, and the comparative low cost of Amiga systems, the future of Amiga desktop publishing can only be very, very bright.

CITY DESK  
MicroSearch  
9896 SW Freeway  
Houston TX 77074  
713-988-2818

PROFESSIONAL PAGE  
Gold Disk  
2179 Dunwin Dr. #6  
Mississauga ON Canada L5L-1X2  
416-828-0913

SHAKESPEARE  
Infinity Software  
1144 65th St. Suite C  
Emeryville CA 94608  
415-420-1551



# SHOW REPORTS

*The last couple of months have seen not one, but three great computer shows. Here's an INFO guided tour of all three!*

## The Commodore Show- Anaheim

by Mark R. Brown

*Dateline Disneyland:* Mickey Mouse, 100-degree temperatures, earthquakes, and Commodore computers--what could make for a more exciting October weekend? Those were the key elements surrounding the *Commodore Show* in Anaheim, a weekend many happy survivors referred to as "Shake and Bake".

This year's show was almost twice as big as last year's LA gathering. The exhibit hall of the Disneyland Hotel was filled to near-capacity with Commodore third-party developers. Only two booths were empty--Compute! and Ahoy!, perhaps scared away by the previous day's earthquake and the likelihood of aftershocks. A strong aftershock *did* shake up the place, but didn't interrupt any of the show's activities. It just woke us all up at 4 o'clock Sunday morning.

I was a speaker at the show, along with Dale Luck, R.J. Mical, Jim Butterfield, and many others from the 8-bit and Amiga community. It was great meeting LA-area Commodore users and telling them how we produce INFO.

On the show floor, there was a *lot* of Amiga activity. The 8-bit developers were there, but without the flash and fervor that surrounded the Amiga booths--most of the 8-bit products had been seen before.

### 8-BIT STUFF

Among the companies presenting C64/128 products, Jason-Rannheim was showing their *Promenade* and *CCSZ* clock-calendar cartridge. Ketek had their C64 and C128 enclosures there (all the way from Iowa City!). Slide Mountain Systems was showing the *MicroTroll*. Mountain Wizardry debuted a new C128 version of the *Midnight Assembly System*. Oceanic was showing the *Excelerator Plus* 1541-clone drive. QuantumLink had a double booth. I ran into Jim Butterfield there, catching up on his QMail. SOGWAP was demoing *Big Blue Reader CP/M* for the C128 & 1571 drive, and was talking about *Little Blue Reader*, coming for the C64 with 1571. American Made Software had the *Micro Detective* BASIC debugger up and running. Free Spirit was there, and so were Bobco, Broderbund, and a few others.



*Commodore spokesperson Pete Baczor explains the merits of the Amiga to show attendees.*

### CROSSOVERS

Briwall had a multiple booth featuring the wares of several companies. INCA had *CP/M Kit* for the C128; Inkwell Systems had their new lightpen and *Flexidraw 5.0* software; CDA demoed *Moving Pictures* and *The Graphics Transformer* for the C64, and *Lexcheck* for the Amiga; Patech's programmers David Darus and Lou Wallace were on hand to personally demonstrate their innovative *BASIC 8.0* for the 128 (we had a long talk about how piracy is cutting into their sales); and Briwall was showing some of their own products, including the C128 CAD program *Home Designer*.

Skyles Electric Works was there with a table full of Amiga memory boards, 64/128 IEEE interfaces, and the like. The PitchRider MIDI interface folks had interfaces for all Commodore machines. And MicroIllusions had a long lineup of computers demoing C64 and Amiga games, including *Firepower*; one corner of their booth was devoted to MIDI keyboard equipment with an Amiga running *Music-X*.

### AMIGA STUFF

On the Amiga-only front, there was Spirit Technology's *InBoard* internal up-to-1.5-meg RAM expansion board for the A500. Our favorite feature: the "How-To-Install Slide Show" on the accompanying disk.

Crystal Rose's *Analytic Art* is a commercial Mandelbrot set generation program, with many options. But my favorite features are the "Convert-to-Sphere" and "Convert-to-3D" support programs, which work with any IFF files. They are fine stand-alone video

production tools in their own right, and make it fun to create short animated sequences like spinning spheres and "peel-away" screens (I use them in conjunction with Eric Graham's public domain *Movie* program). Great stuff!

Mimetics was showing a 2 million color professional video board for the Amiga called *ReaSyn*. This \$700 marvel captures NTSC broadcast images in up to 746x480 resolution. Two optional \$200 add-on boards provide real-time digitizing and automatic VCR-control capabilities. Their new *ImaGen* genlock will be available soon in regular (\$180) and *Pro* (\$?) versions. There's also a hardware add-on (\$200) that interfaces SoundScape to SMPTE time-code for professional soundtrack scoring.

MicroSearch was showing *City Desk* and *Perfect Sound* from SunRize, but they were still just talking about the *Perfect Vision* digitizer (available by the time you read this).

The folks from PDJ Software were showing the latest version of their *AiRT* icon programming language for the Amiga. Also at the show were Micro Magic, Oxxi, Aegis, WordPerfect, Hash Enterprises, InterActive Softworks, Broderbund, Sedona Software, Byte-by-Byte, and many others.

Meridian had *The Demonstrator*, a mouse-and-keystroke recording and playback system. Discovery Software had their new arcade game, *Arkanoid*, up and running at a booth just inside

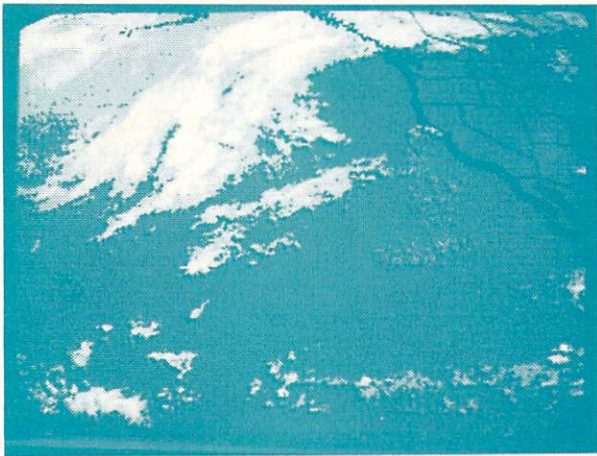

*Digi-Weather, from Felsina Software.*

the entrance, and it was stopping traffic.

Expansion Technologies and Pacific Peripherals were both showing expansion boxes for the A500; Expansion's fits on top of the computer and has 2 megs of RAM with room for optional floppy and hard drive; Pacific's *SubSystem* sits under the computer and gives your A500 two A2000-style expansion slots,

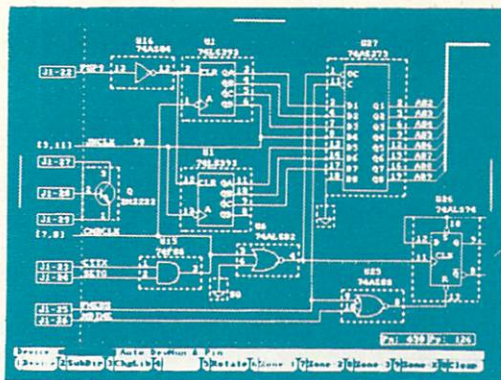

*Pro-Net CAD, from Prolific.*

with room for an optional floppy.

PAR Software had v1.1 of *Express Paint* (\$80), with half-brite support for 64 colors and the ability to produce pictures up to 8000x8000.

Brown-Wagh's latest is *TV\*SHOW* (\$100) from Zuma Group, a multi-talented slideshow program with HAM support, fades, and more.

## FUN STUFF

There were some exciting product announcements at the show, and some other things that we saw for the very first time. Some of the products that "debuted" at the AmiExpo Show in New York the following weekend were actually shown at The Commodore Show first!

One of these was *LIVE!*, the long-awaited "official" Amiga video digitizer, now out of Commodore's hands and being marketed by its developers, A-Squared. It does digitize fast, but it didn't look to me like it captures the detail that That Other Digitizer does--we'll reserve judgement until we get one in to play with.

Two companies were showing bare-bones expansion boards for the Amiga. BareBoards has bare memory boards for the A1000, with A500 and A2000 versions coming soon. A bare 4 meg board is \$79.95 (\$133 with support chips but no RAM), with populated boards available in 512K increments. A 2-meg version is \$296. Bill's Boards has a complete A2000-style expansion chassis board for the A500 with up to 6 Amiga slots, 3 optional bridge slots, and up to 6 IBM AT compatible slots, all for \$495.95. The card is designed to fit into a user-supplied surplus baby AT box with power supply (less than \$125).

CXP was talking 512K, 2 meg, and 0-8 meg boards for all 3 Amigas priced from \$95 (unpopulated 512K) to \$1495 (loaded 8 meg).

*Project D* v1.1 is a new archival copier from Fuller Computer Systems. Besides a copier, the \$50 disk includes a sector editor, disk cataloger, and copiers for MS/DOS, ST, Xenix, and CP/M.

HyperTek's contribution to the Amiga cause includes a new flicker-free hires monochrome monitor for only \$179. It hooks to the RGB port and provides an RGB pass-thru for your color

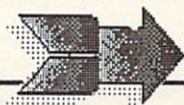

...SHOW REPORT continued

# AmiExpo- New York

by Peggy Herrington

monitor. The picture looks sharp! They've also got a light pen and a MIDI interface.

The new *Pro-Net* and *Pro-Board* pc-board CAD systems from Prolific are interesting new circuit-layout and board production CAD programs for the Amiga. Features: auto-routing, 4-layer plus silkscreen support, and net lists. Demo disks for \$15/each, or \$475 per module.

Felsina Software neatly removed my socks with *Digi-Weather*, a terminal program that allows the Amiga to access the online *Accu-Data* services for downloading professional-TV quality satellite weather photos and radar information. The files produced are IFF-compatible, so you can use this term program in combination with video production software to put together TV-station-quality professional weather reports. Their demo disk, complete with "in-motion" satellite weather pictures, is great!

Finally Software's newest product is hardware: the *Hurricane Accelerator Board* plugs into the Amiga's 68000 cpu chip socket, providing sockets for a 68020 and 68881 math co-processor chip that run at 16 MHz. There's also a piggyback 2-meg (32-bit) optional memory card. Either is \$495 sans chips.

InnoVision Technology was demoing an early version of *Video Effects 3D* (\$249), a video production tool that will provide zooms, perspective, rotation, and many other video effects. The package is modular, to provide for further add-on effects. Once rendered, it will play back up to 20 seconds of video in realtime on a 1-meg Amiga.

Last, but not least, if you've been looking for carrying cases for your Amiga equipment, you can get them from PACE in grey or navy.

## COMMODORE

There was no hot news from Commodore at the show, but their presence seemed to have a calming effect on the gathering. Just seeing Commodore displaying at shows again is very nice. Their booth was grey and corporate, and everyone wore suits and ties, but the folks were friendly and even a little enthusiastic.

## DISNEYLAND

This was also my first trip to Disneyland, and as far as I'm concerned, they can hold *The Commodore Show* there every year! The high-tech attractions were dynamite! I had a great time in the Haunted Mansion with its 3D hologram "spooks", thoroughly enjoyed myself in the new Star Tours simulated spaceflight, and loved the "surround" theatre. What a great place for a techie to hang out after a computer show!

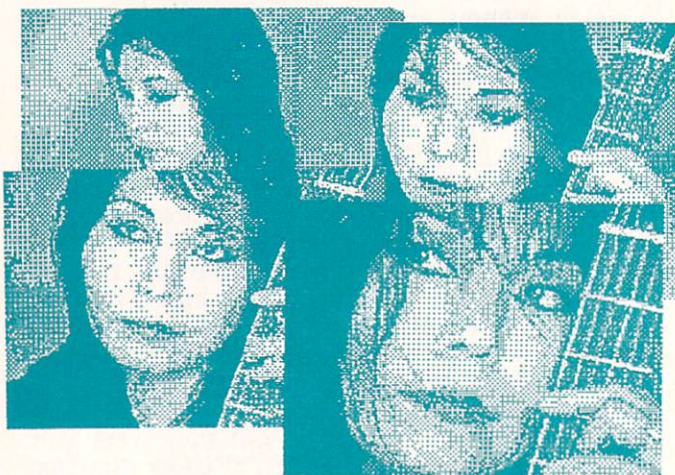

*Live sequential images from Amiga LIVE!*

As my adrenalin level shot up on the way from La Guardia to Manhattan Island, I was hoping it would be a good show. But just like every New York City cab ride I experienced (and they *were* experiences), October's AmiEXPO surpassed my wildest expectations. Three days, 60-some exhibits, three dozen seminars and 8,325 Amiga fans later, I decided it had been worth the ride.

## SHOW STOPPERS

Elbowing my way through the huge, jam-packed basement level of the Sheraton Towers, I saw lots of interesting new and long-awaited products, including C64 emulators from ReadySoft and Software Insight [see sidebar].

Among the exciting new hardware products were ASDG's 8-megabyte A2000 expansion board and their *Satellite Disk Processor*, a hard disk controller for the A1000 or 2000. It's a single-board 68000 microcomputer with SCSI (\$800) or ST506 (\$950) connectors and optional floating-point math processor. ASDG also demoed *FACC II*, their floppy disk accelerator software, and showed a new product that may give A1000 owners pause as they consider upgrading to the A2000. Called the *2000-and-1*, it's an A1000 box that provides all A2000 expansion slots including those for the Bridge card (but no video) with a 200-watt power supply and space for three drives (\$800).

Live!, the much-awaited real-time video digitizer, was putting moving images on the screen in A-Squared's exhibit. Live! sits neatly under the monitor, and the software has been enhanced with features like 4,096-color HAM digitizing and overscan. It's shipping now.

Toronto's Very Vivid, Inc. (the producers of the multi-media Amiga-driven performance at last year's World of Commodore Show) was showing new software called MIDIVision (\$395). Used with a real-time digitizer (\$295), MIDIVision lets you play sounds on MIDI-connected music synthesizers by moving your body and arms (which some call dancing) in front of a video camera (any model, b/w or color, with sync out). MIDIVision digitizes your moving image over gorgeous screens of musical instruments and exotic jungle settings, letting you play melodies and drums with pre-recorded harmonies, and make preprogrammed changes as your image touches "hot spots" on the screen. They'll also offer *Body Paint* (\$80) in early '88.

Supra was selling Hayes-compatible 2400 Baud modems with LEDs and speaker for only \$179, and discussed with us their new FD-10 disk drive that allows 10-megabytes of data to be stored on a single high-density 5-1/4 floppy disk. Available for the Amiga in early 1988, the FD-10 will retail for \$895, with high-density disks costing \$39 each, making the system affordable and fast enough to be used for hard disk back-up or as primary storage.

BYTE by BYTE showed *The Byte Box*, an A500 memory expansion system sitting neatly under an external disk drive (\$299.95 unpopulated, 512K=\$399.95, 1M=\$499.95, 2M=\$699.95). Also introducing A500 expansion RAM was Spirit Technologies with an internal board unpopulated for \$279.50 (1.5M=\$579.50).

## ANIMATION GOODIES

BYTE by BYTE previewed *Animate-3D* (\$149.95), software that takes shiny ray-traced objects created with *Sculpt 3D* (\$99.95) and moves them in dazzlingly smooth animations. Across the hall, Impulse was selling *Silver* (\$169), their new ray-tracing animation software which looked slick, too.

Along with other products, Associated Computer Services announced that their EF/X storyboard editor/controller software will be distributed as *Deluxe Productions* by Electronic Arts. It has more features (wipes, fonts, etc.) and is reputedly easier to use than *Deluxe Video*. And if your hand needs steadying when you draw or trace, *Mouse Trace* (\$60), a clever hardware mouse-guide by Crystal Innovations will be available in early 1988.

*Forms in Flight* animation software (not IFF compatible) was demonstrated by MicroMagic, and MicroIllusions showed *Cell Animation*, first in a series of products they say will culminate in broadcast-quality results from the A2000.

NewTek told me about their upcoming project based on the *Maxine Headroom* parody they've

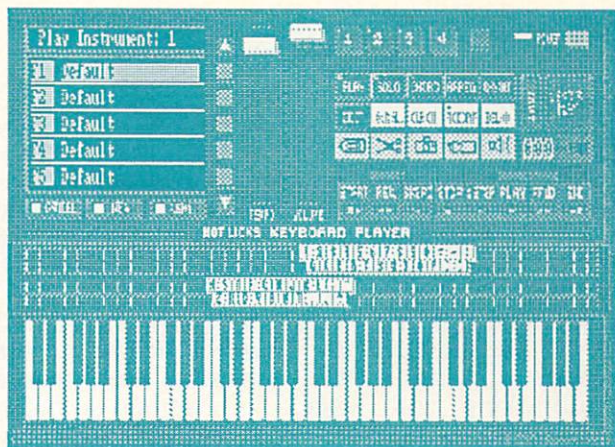

*Infinity Software's HotLicks.*

shown at several shows. NewTek will reveal the product (which their *Laser Toaster\** joke has successfully smokescreened) at COMDEX.

## FUN AND GAMES

Florida's DigiTek, Inc. showed several new games which are German imports: *Amegas*, *Thunder Boy*, *Hollywood Poker* and *Extensor*.

*Amiga Jet* (\$49.95) from subLOGIC was finally previewed, as was *Go* (\$39.95) from Infinity Software. *Head Coach*, a pro football simulation, was shown by MicroSearch, and Activision (distributors of MicroIllusions entertainment products) made hits with *FirePower* and *Blackjack Academy*. Psygnosis was there with *TerrorPods* (distributed by CSS) and Discovery Software showed *Arkanoid*.

Several games were previewed by Vertex including a PacMan look-alike with mega-levels of play and another using 60 frame per second animation. Vertex sold-out issue #4 of their disk-based Amiga magazine, *AMnews*. Featuring three monthly disks of animations, music and smooth-scrolling text for \$9.95, *AMnews* looks like the Amiga was made for it.

## SOUNDS AND MUSIC

Judging from the number of new tuneful products, it sounds like Amiga music is coming of age. Infinity Software showed *HotLicks* (\$49.95), music composition software with built-in rhythm guides, an onscreen keyboard with tape recorder-like controls and a jukebox that plays IFF 8SVX samples in Simple MUSIC format. *Synthia* (\$99) from The Other Guys edits or builds complex IFF instruments in five separate modules, and includes a SMUSIC player.

Aegis released *AudioMaster* (\$59.95), sound

\* An Amiga peripheral reportedly capable of producing, via lasers, hotel emblems and other graphics in 32-crumbs per inch resolution on toast, with optional 8-color jelly jets and "HAM-on-toast" mode.

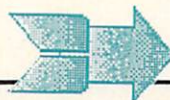

## ...SHOW REPORT continued

editing software that works in both IFF and Sonix RFF formats and can use external RAM to playback enormous blocks of digitized sounds. **StudioMagic** (\$99) from MicroSearch not only edits IFF sounds, it has a built-in sequencer that works with internal sounds or those from MIDI-connected synths.

Serious MIDI enthusiasts will be interested in new Intuition-based **Texture** (\$199) from Magnetic Music. Now utilizing the mouse, multitasking and color, for timing accuracy **Texture** still requires its own interface (\$50) and Roland's MPU-401 smart MIDI-interface (around \$200 discounted). And SoundQuest, Inc. introduced several gorgeous MIDI librarian/editors for the Yamaha DX series and Roland D-50 (\$125 to \$180).

**DynamicDrums** (\$79.95) from New Wave is a software-based drum machine that syncs to MIDI but plays Amiga IFF internal sounds. (They also have a MIDI sequencer in the works.) One of the neatest offerings was **MusicMouse** from OpCode Systems which turns the Amiga into a musical instrument using MIDI or four internal voices. It displays interesting graphics and multitasks with **Deluxe Music** or as a module in **Mimetics' ProMIDI Studio**.

## VIDEO VISIONS

Mimetics was entertaining a crowd in an upstairs ballroom, showing 23 new modules for **Pro-MIDI Studio** and demonstrating their newest ventures: **ImaGen** (\$179.95), a tiny genlock for all Amiga models (providing composite out on the A500), and **FrameBuffer** (\$699.95) with optional **FrameCapture** software (\$199.95) designed for the A2000.

DesignLab showed a professional frame-buffer (about \$2,000) that can be built-out to handle multi-channel, true color digitizations (about \$3500), and **FinePrint** software (\$50) which prints B/W shaded rather than dithered images and has special drivers for something like 75 printers. They demoed **Infinico's PHOTOR** (around \$1,000) a product similar to the Polaroid Palette, but uses *your* 35mm camera.

## PRODUCTIVE PRODUCTS

Desktop publishing was represented by Gold Disk previewing **PostScript compatible Professional Page** (\$395) software. They introduced **ComicSetter** (\$99) for making (what else?) 16-color comic books and **Professional Color** separating software (\$195). (Check out **PIXmate** (\$69.95) from Progressive Peripherals for 4-color separation and gray scaling, too.) MicroSearch is producing a newsletter with **CityDesk II** (\$149.95), which is **WordPerfect**

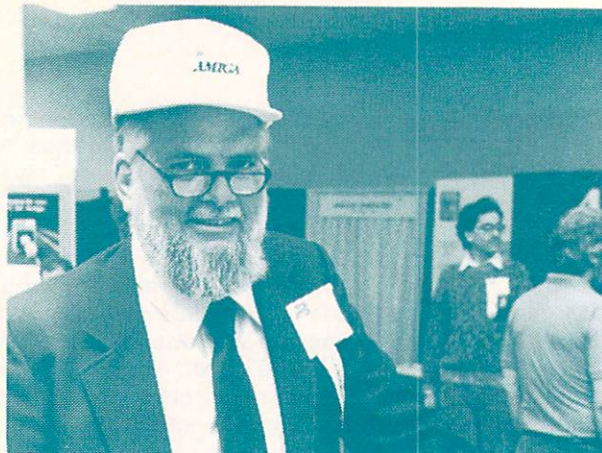

*Jay Miner, Father of the Amiga, and speaker.*

compatible (they were there too) and Infinity demoed **Shakespeare** (\$225).

Brown-Wagh previewed **Write & File** (\$99), a new WYSIWYG multiple-font word processor with built-in database and spell checker. Speaking of fonts, InterActive Softworks showed their fine collection, **Calligrapher** (\$99), and new **Newsletter** (\$30) and **Studio Fonts** (\$35).

Fuller Computer Systems introduced **Project D** (\$49.95). Hugh's Software Ranch printed IFF graphics at 8-1/2 x 13 FEET with **HUGHprint** software. A staggering collection of public domain software was available from Public Domain Software Copying Co. including disks (\$4.50 each, mailorder) from Amicus, Boston Computer Society, Fred Fish, I.C.P.U.G., LICA, MARCA, NCAUG and New Age. Meridian Software introduced **The Demonstrator** (\$39.95), software that records keyboard and mouse moves in real-time for presentation later.

Lattice demoed their **V4.0 Lattice C Compiler** with improved speed and link times, and Manx showed the source-level debugger (\$75) being released with V3.6. A new language for the Amiga is **APL** (\$99) from Spencer Organization.

## AFTERSHOCKS

As you can tell, AmiEXPO was a fast-paced, high-energy event and even three days weren't enough to see all the exhibits and catch many of the seminars presented by industry luminaries. Audio cassettes of the seminars (everything from LAN to Lasers) and keynote addresses by Jay Miner, R.J. Mical and Rich McIntyre are available for \$9 each from Audio Transcripts.

If you can't make it to the Big Apple next October, maybe you can catch another AmiEXPO. Upcoming AmiEXPOs are set for Jan. 16-18, 1988 at the Westin Bonaventure in Los Angeles, and July 22-24 at the Hyatt Regency in Chicago. They promise to be major Amiga gatherings and, provided I survive the cab ride, maybe I'll see *you* there.



# COMDEX - Las Vegas

by Benn Dunnington

Last year I attended CES in Las Vegas. I had the flu and it was snowing. This year I covered COMDEX and things were only slightly improved: I had walking pneumonia and Vegas was drenched in record rains for 3 days straight.

## THE SHOW

This COMDEX was the biggest ever, with exhibits spread out into every conference room in every hotel in town. Just getting around to see things was a major struggle, and the waiting lines for cabs as the show closed each night were over an hour long.

As usual, the majority of the exhibits were IBM/PC oriented. After all, this is a business show. But a little detective work led me to a few small centers of Commodore Amiga activity.

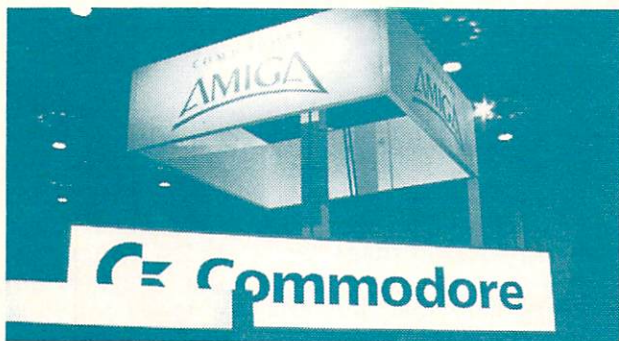

## THE COMMODORE BOOTH

The major focus for Amiga fans was Commodore's own booth in a corner of the West Hall. Rainwater kept dripping down from the ceiling vents near the equipment, but nothing in the booth got hurt by it that I could see. Some less fortunate exhibitors were walking around buckets and even working under plastic sheets.

All of Commodore's top brass was at the show. CBM's new President, Max Toy, had given an address at the Commodore's dealer showing on Sunday. Everybody who heard him speak walked away reassured about CBM's direction. In the booth, I made sure that Al Duncan, Rich McIntyre, Frank Leonardi, Henri Ruben, and the CBM technical support staff all received complimentary INFO pocket protectors.

In the booth was the usual assortment of third party companies showing their wares. There were few major introductions at COMDEX; most of the new products had already debuted at AmiExpo or The Commodore Show. I'll let Peggy and Mark fill you in on those.

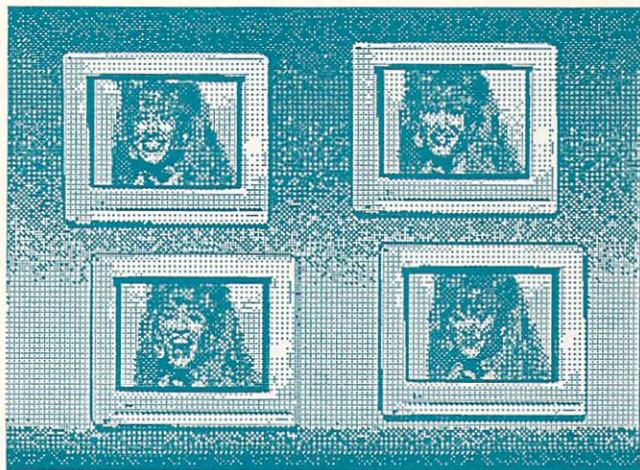

The infamous Maxine Headroom, from a NewTek demo disk.

## THE NEW STUFF

There were a few hot items. Taurus announced the release of their long-awaited X-CAD system. This powerful 256-layer 2D CAD package has literally too many features to list, but it is said to achieve speeds of up to 3000 lines/second, and with a 68020 it can outrun a VAX.

Gold Disk is attacking desktop publishing from both directions. On the serious side, there's Professional Page, which supports PostScript printers, does full kerning, microspacing, and all the rest, and even has an optional 4-color separation module (see preview elsewhere in this issue). On the lighter side, there's Comic Setter, which lets you and your Amiga produce color comics with panel layouts and speech balloons.

One interesting "little" product was Interchange from Syndesis. This program lets you transfer 3D objects back and forth between VideoScape 3D and Sculpt 3D.

## THE VIDEO TOASTER

In NewTek's corner, Paul Montgomery manned the booth while boss Tim Jenison labored away in his hotel room for the first two days of the show, rushing to get some demo software done for their new Video Toaster Amiga add-on board. I talked to the board's designer, Brad Carvey (who just happens to be the brother of Dana Carvey, the "Church Lady" on Saturday Nite Live). He told me that the Toaster will essentially turn an Amiga into the equivalent of a \$30,000 dedicated video special effects station. Standard features include a broadcast-quality Genlock, 1/60 of a second full-color frame capture, frame buffering for displays that reproduce millions of colors, and software-controllable real-time video effects like peels and stop-motion. The best news is the price: \$799.95. If delivered as billed, it will be a

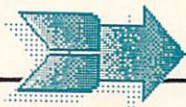

...SHOW REPORT continued

definite breakthrough in video power. Options that NewTek will offer for the *Toaster* include a Targa-graphics-station quality 16-million color NTSC paint program, professional chroma key, a programmable video switcher, and more. Though I left town before Jenison had the software up and running, I've heard from people who saw the demo running near the end of the show who say it was displaying real-time images of the spectators in a rotating frame, an effect only the TV networks could afford 'till now.

## ELSEWHERE

There were some third party companies who weren't gathered under Commodore's roof (leaky as that might have been). **Progressive Peripherals & Software** seemed to have the most going on. The product that interested me most was the long-awaited **Superbase Professional**. This pup is loaded with features, and promises to be *the* database for the Amiga, just as its siblings were for the C128 and C64.

*Access-64* promises to be an innovative solution to porting those databases (and wordprocessing documents) from your C64/128 to your Amiga. This \$80 program-and-hardware package is billed as "Not A C64 Emulator". It simply lets you use your 8-bit serial buss peripherals on your Amiga. 1541, 1571, or 1581 drives become Amiga devices DF8: or DF9:, a Commodore serial printer becomes your PRT: device. It's as simple as that. While C64 emulators are interesting curiosities, this product addresses the more practical side of upgrading.

PP&S demoed some nice new Amiga products at COMDEX. The *EXP-8000+* gives your A500 up to 8 megabytes of RAM *internally*. It uses a new patented low-power design. They've got a small & sexy 3.5" drive for \$240 (\$190 in an internal version for the A2000) that's about half the size of the Amiga external drive.

Their new *FrameGrabber* digitizer has its own frame-buffer RAM, so it can capture a picture in 1/60 of a second using a standard home video color camera, then feed it into the Amiga's memory for processing. It will digitize both B&W and 4096-color HAM images. No price yet. They've also joined the Genlock Wars with their *ProGEN* unit for all Amiga machines, due out by the time you read this.

Progressive also showed two new CAD packages at COMDEX. *IntroCAD* is an inexpensive (\$79.95) CAD program for the student, novice, or occasional user. For an introductory package, it seems to be well-equipped, with multi-level zoom, user-definable parts libraries, snap-to-grid, and many options. Its print routines have been optimized to



Commodore's corner at COMDEX.

produce quad-density printouts on standard dot-matrix printers. *UltraCAD* is their professional package, and looks like it's got a full load of features for producing, manipulating, and printing drawings. No price on it yet.

As you can see, there was a *lot* to see at the Progressive Peripherals booth!

## ATARI

Atari's booth was in the Main Hall, across the street from the West Hall and Commodore's booth. Their booth was monochromatic, as befits a "business" show. Strangely enough, almost all the products being demoed in the booth were on *Mega STs* with *monochrome* monitors--were color displays too suggestive of video games?

There was no real news at the Atari booth, except perhaps that they are now really shipping the *Mega STs* in the U.S. They announced a local area network for STs, MACs and PCs. Its name? "*Moses PromiseLAN*". Really. We couldn't make this stuff up.

They had about a half dozen of their prototype Transputer-based *ABAQ* computers set up with *Mega STs* as terminal/workstations. They were running some pretty simple raytraced-and-animated rotating balls demos. There was a lot of noise about what a breakthrough the *ABAQ* was, but Atari had: (1) No firm price, (2) No delivery date, and (3) No software for it. It's pretty obvious that this was just another Atari dog-and-pony show. It was encouraging to see very few people falling for it this time around.

Atari also had a few of their *Mega ST* desktop publishing systems sitting around, but they suffer from a serious design flaw that will, I think, prove fatal: The ST acts as the brains of the laser printer (a bulky, unattractive unit). This means the system locks up while driving the printer. You also can never upgrade your printer or sell it to anyone else unless they have an ST, too. The price is also a killer, at \$4000 for the *Mega ST*, laser printer, and monitor. You can buy an A500, inexpensive laser printer,

monitor, and software for that, and have a much more versatile, expandable system.

The concensus seems to be that Atari is fading from the personal computer market, but they have enough videogame money to kick and scream for a long, long, time.

## THE WRAP

This was billed as "The Biggest COMDEX Show Ever". It was. And in the endless sea of IBM exhibits, the Amiga booths were welcome and refreshing islands.

# SHOW EXHIBITORS

- A-Squared**  
6114 LaSalle Ave #326  
Oakland CA 94611  
415-339-0339
- Activision**  
2350 Bayshore Frontage Rd  
Mountain View CA 94043  
415-960-0410
- Aegis Development Inc**  
2110 Wilshire Blvd #277  
Santa Monica CA 90403  
213-392-9972
- American Made Software**  
PO Box 323  
Loomis CA 95650
- AmiEXPO Show Headquarters**  
211 East 43rd Street #301  
New York NY 10017  
800-32-AMIGA
- Audio Transcripts Ltd**  
610 Madison St Dept 388-87  
Alexandria VA 22314  
703-549-7334
- ASDC Inc**  
280 River Road #54A  
Piscataway NJ 08854  
201-563-0529
- Associated Computer Services**  
1306 East Sunshine  
Springfield MO 65804  
416-837-7373
- Bare Boards**  
4960 Almaden Expwy MS 109  
San Jose CA 95118  
408-629-7838
- Bill's Boards**  
9528 Miramar Rd #181  
San Diego CA 92126  
619-578-8719
- Bobco**  
200 7th Ave #111  
Santa Cruz CA 95062  
408-462-1551
- Briwall**  
PO Box 129  
Kutztown PA 19530  
215-683-5433
- Brown-Wagh Publishing**  
16795 Lark Ave #210  
Los Gatos CA 95030  
408-395-8338
- BYTE by BYTE Corp**  
9442 Capof Texas Hwy N  
#150  
Austin TX 78759  
512-343-4357
- CDA**  
PO Box 1052  
Yreka CA 96097  
916-842-3431
- Commodore Business Machines**  
1200 Wilson Dr  
West Chester PA 19380  
215-431-9100
- Computer Software Service**  
2150 Executive Drive  
Addison IL 60101  
800-422-4912
- CSA**  
7564 Trade Street  
San Diego CA 92121  
619-566-3911
- Crystal Innovations**  
2286 East Steel Road  
St Johns MI 48879  
517-224-8683
- Crystal Rose Software**  
109 S Los Robles  
Pasadena CA 91101  
818-795-6664
- CXP**  
3596 South 300 West #10  
Salt Lake City UT 84115  
801-264-8238
- DesignLab**  
87 Chestnut St  
Owego NY 13827  
607-687-5740
- DigiTek Inc**  
1715 E Fowler Ave #R-122  
Tampa FL 33612  
813-933-8023
- Discovery Software**  
163 Conduit St  
Annapolis MD 21401  
301-268-9877
- Expansion Technologies**  
46127 Landing Pkwy  
Fremont CA 94538  
415-656-2890
- Felsina Software**  
3175 S Hoover St #275  
Los Angeles CA 90007  
213-669-1497
- Finally Technologies**  
25 Van Ness #550  
San Francisco CA 94102  
415-621-5670
- Free Spirit Software**  
538 S Edgewood  
LaGrange IL 60525  
312-352-7323
- Fuller Computer Systems**  
PO Box 9222  
Mesa AZ 85204-0430  
602-335-5018
- Gold Disk Inc**  
2171 Dunwin Dr Unit 13  
Mississauga Ontario L5L 1X2  
416-828-0913
- High's Software Ranch**  
50 East End Ave #4C  
New York NY 10028  
212-879-4651
- Hypertek**  
120-1140 Austin Ave  
Coquitlam BC V3K 3P5  
604-939-8235
- Impulse Inc**  
6870 Shingle Creek Pkwy  
#110  
Minneapolis MN 55430  
612-566-0221
- INCA**  
PO Box 789  
Imperial Beach CA 92032  
619-477-2024
- Infinity Software Inc**  
1144 65th St #C  
Emeryville CA 94608  
415-420-1551
- Inkwell**  
57 Ruffin  
San Diego CA 92123  
619-268-8792
- Info Vision Systems**  
PO Box 743  
Hayward CA 94543  
415-538-8355
- Interactive Softworks**  
57 Post Street #811  
San Francisco CA 94104  
415-956-2690
- Jason-Ranheim**  
1805 Industrial Dr  
Auburn CA 95603  
916-823-3284
- Ketek**  
PO Box 201  
Oakdale IA 52319
- Lattice Inc**  
2500 S Highland Ave  
Lombard IL 60148  
312-916-1600
- Magnetic Music**  
Rd 5 Box 227A Myrtle Dr  
Mahopac NY 10541  
914-248-8208
- Mapx Software Systems**  
1 Industrial Way  
Eatontown NJ 07724  
201-542-2750
- Meridian Software Inc**  
240 Eldorado #2108  
Webster TX 77598  
713-488-2144
- MicroIllusions**  
17408 Chatsworth St  
Granada Hills CA 91344  
818-360-3715
- MicroMagic**  
261 Hamilton Ave #320B  
Palo Alto CA 94301  
415-327-9107
- MicroSearch Inc**  
9896 Southwest Freeway  
Houston TX 77074  
713-988-2818
- Mimetics Corporation**  
PO Box 1560  
Cupertino CA 95014  
408-741-0117
- Mountain Wizardry Software**  
PO Box 66134  
Portland OR 97266
- NewWave Software Co**  
PO Box 438  
St Clair Shores MI 48080  
313-771-4465
- NewTek Inc**  
701 Jackson #B3  
Topeka KS 66603  
913-354-9332
- Oceanic-SCI**  
PO Box 1836  
Capitola CA 95010  
800-544-6274
- OpCode Systems**  
1024 Hamilton Ct  
Menlo Park CA 94025  
415-321-8977
- PACE**  
PO Box 3302  
152 South 600 West  
Logan UT 84321  
801-753-1031
- Pacific Peripherals**  
PO Box 14575  
Fremont CA 94539  
415-651-1905
- PAR Software**  
PO Box 1089  
Vancouver WA 98666  
206-694-1539
- Patech**  
c/o Computer Mart  
1700 NE Andresen Rd  
Vancouver WA 98661  
206-695-1393
- PD Software**  
111 Thornwood Dr  
Marlton NJ 08053
- Pitcher-IVL Technologies**  
3318 Oak St  
Victoria BC V8X 1R2  
Canada
- Progressive Peripherals & Software**  
464 Kalamath St  
Denver CO 80204  
303-825-4144
- Prolific Inc**  
1808 W Southgate Ave  
Fullerton CA 92633  
714-447-8792
- Public Domain Software Copying**  
33 Gold St L-3  
New York NY 10038  
800-221-7372
- QuantumLink**  
8619 Westwood Center Dr  
#200  
Vienna VA 22180  
800-782-2278x1097
- Skyles Electric Works**  
231 S Whisman Rd  
Mountain View CA 94041  
415-965-1735
- Slide Mountain Systems**  
PO Box 6481  
Colorado Springs CO 80934  
303-449-4783
- Software Visions Inc**  
26 Forest Road  
Framingham MA 01701  
800-527-7014
- SOGWAP**  
611 Boccaccio Ave  
Venice CA 90291  
213-822-1138
- SoundQuest Inc**  
5 Glenaden Ave East  
Toronto Ontario M8Y 2L2  
416-234-0347
- Spencer Organization Inc**  
366 Kinderkamack Rd  
Westwood NJ 07675  
201-666-6011
- Spirit Technology Corp**  
220 West 2950 South  
Salt Lake City UT 84115  
801-485-4233
- subLOGIC Inc**  
713 Edgebrook Drive  
Champaign IL 61820  
217-359-8482
- SunRise Industries**  
PO Box 1453  
College Station TX 77841  
409-846-1311
- Supra Corporation**  
1133 Commercial Way SE  
Albany OR 97321  
503-967-9075
- Syndesis**  
20 West St  
Wilmington MA 01887
- Taurus-Impex dist by**  
Haitex Resources  
208 Carrollton Park #1207  
Carrollton TX 75006  
214-241-8030
- The Other Guys**  
55 North Main St #301-D  
PO Box H  
Logan UT 84321  
800-942-9402
- Vertex Associates**  
415 Trenton Avenue  
Montreal Quebec H3P 2A1  
514-739-3301
- Very Vivid Inc**  
6012 Yonge St #115  
Toronto Ontario M2M 3V9  
416-537-7222
- Zuma Group**  
6733 N Black Canyon Hwy  
Phoenix AZ 85015

# EMULATING THE C64

## THE AMIGA AS A C64

C64 owners have for many moons now pondered ways of taking their extensive collections of software, peripherals and data files with them when they upgrade to Commodore 32-bit technology. And (although many of us still wonder why) rumors about an upgrade path have turned out to be *doubly* true: Not one but *two* C64 emulators were in evidence at AmiEXPO.

They differ from each other dramatically, and at this point I wouldn't call either one a killer. Both take over the system (precluding multitasking) and neither permits QuantumLink access (yet). They won't work with C64 user port modems (because no such port exists on the Amiga) and it's uncertain whether they work with the 1581 drive, although both claim C64 hard drive and GEOS compatibility.

## THE 64 EMULATOR

There are two versions of ReadySoft's emulator, but the \$59.95 version includes a cable for connecting 1541/71 disk drives and printers to the Amiga. Software includes routines for converting C64 data to Amiga-DOS, *two* emulations for GEOS and one for everything else. Provided they load in the first place, programs with moving backgrounds (like flight simulators) run slowly, but pinball and karate-type games reputedly move at full speed. Color and sound are supported and an optional monochrome mode is supposed to increase program speed, but the 64 Emulator doesn't handle fast loads, which is why QLink won't work.

## GO-64!

Software Insight claims 80% compatibility with GO-64!, which comes with a tiny Amiga serial interface box into which you plug a 1541/71 drive or printer. The emulation is at chip level, accomplished with "hypercodes" (similar to Marauder's "brain files") which Software Insights is developing for specific programs. You must supply one for each and every commercial program you want to run. They have a BBS for future hypercodes and say they'll provide free program upgrades, the first of which will handle data file conversions and modems, which it doesn't now. GO-64! doesn't support C64 sound or handle fastloads. As to speed of operation,

all I can say now is that it varies, though it's optimized for BASIC operation, so it runs BASIC faster than ReadySoft's emulator.

## WHY BOTHER?

Two rationales seem to drive the desire to use 8-bit Commodore products on the Amiga; one is to save time, the other money. Would-be time savers want to access C64 data files created with programs like Paperclip and Superbase on the Amiga without re-keying them. While I haven't used either emulator much (we'll have an in-depth review on both models in the next issue), if you need to transfer files from the C64 to the Amiga, you now have several options, but it looks like the cheapest and fastest solution might be to go ahead and use ReadySoft's 64 Emulator.

If you're a money-saver, you probably want to use C64 programs and peripherals. For now, it appears that ReadySoft's emulator is more impressive, due mainly to its modem and sound support. But because Software Insight's hypercodes will address complex issues like individual copy-protection schemes (which ReadySoft doesn't), you may have better luck with GO-64! in the long run -- provided they develop the hypercodes for the programs you want to run. Even then, you probably won't be happy for long. No emulator will ever work like the real thing, and once you've been dazzled by Amiga graphics, sound and multitasking, you'll be satisfied with nothing less than Amiga software.

The moral? While a C64 emulator might be an effective spousal argument for upgrading, and it makes sense as far as having a medium for translating files back and forth, be aware that it's temporary and plan your strategy accordingly. If you really have a lot of use for your C64, we suggest you keep it.

The 64 Emulator (59.95)  
ReadySoft Inc.  
PO Box 1222  
Lewiston NY 14092  
416/731-4175

GO-64! (\$69.95)  
Software Insight Systems  
16E International Dr.  
East Grandy CN 06026  
203/653-5086



# BUTCHER

OK, so the name is a little strange. Butcher 2.0 includes some strange utilities that you won't find in paint programs. It also includes powerful features for manipulating your pictures. Features like edge detection, resolution changes, pixel counting, half-toning, bit-plané slicing, sorting colors by pixel counts or intensity, density slicing, and palette effects like toning, positive-negative reversing, color separation, complementing, and false colors. You can also change a picture into a mosaic of colored shapes. Use the shape editor to define the shape. Butcher does the rest. Imagine a picture transformed into bricks, diamonds, hearts, or even shredded wheat.

Butcher 2.0 supports color cycling, video overscan, spare screens, and pictures larger than the screen. It requires 512K RAM and Kickstart 1.2. IFF compatible.

## \$37

Add \$2 for shipping and handling  
VA residents add 4.5% sales tax

**Eagle Tree Software**

P.O. Box 164  
Hopewell, VA 23860  
(804) 452-0623

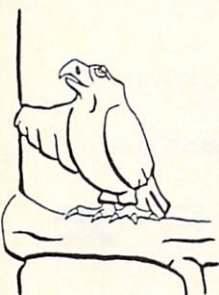

## OVERBYTE COMPUTER SOFTWARE

P.O. BOX 82302  
LINCOLN, NEB.

68501-2302  
(402) 477-8773

### MICROBOTICS @

Prod.#700 Starboard2 0k>1m (0k installed in a 1megabyte space)	\$300.00
Prod.#701 Starboard2 0k>2m	\$325.00
Prod.#702 Starboard2 0k>2m+Multifunction Module	\$400.00
Prod.#703 Starboard2 512k>1m	\$350.00
Prod.#704 Starboard2 512k>2m	\$380.00
Prod.#705 Starboard2 512>2m+Multifunction Module	\$445.00
Prod.#706 Starboard2 1m>1m (1meg installed)	\$398.00
Prod.#707 Starboard2 1m>2m	\$430.00
Prod.#708 Starboard2 1m>2m+Multifunction Module	\$490.00
Prod.#709 Starboard2 2m (2meg installed)	\$495.00
Prod.#710 Starboard2 2m+Multifunction Module	\$577.00
Prod.#711 Starboard2 2m+Multifunction+68881fp chip+parity ram	\$919.00
Prod.#712 Upper Deck 0k>1m-adds 2nd meg of ram to any 1meg sb2	\$ 80.00
Prod.#713 Upper Deck 1m>1m-adds 2nd meg of ram to any 1meg sb2	\$230.00
Prod.#714 Multifunction Module for Starboard	\$ 80.00
Prod.#715 Multifunction Module+68881 floating math point	\$399.00
Prod.#716 m68881 floating point math chip	\$250.00
Prod.#717 A500 Standard 512k expansion/clock	\$130.00
Prod.#718 Mas-Drive20 parallel interface 20meg SCSI hard disk	\$1350.00
Prod.#719 Starboard2 SCSI Hard Disk interface	\$109.95

USER GROUP SPECIAL	Quantity orders of 10 or more
Prod.#709 starboard2 2m	\$460.00
Prod.#711 Starboard2 2m+multifunction+68881fp chip+parity ram	\$819.00
Prod.#718 Mas-Drive20 ect	\$1250.00

### NEWTEX @

Cameras	
Prod.#800 Digiview	\$165.00
Prod.#801 Digipaint	\$ 45.00
Prod.#802 copystand	\$ 62.00
Prod.#803 motorized color wheel	\$ 66.00
Prod.#804 wd 1410 fixed lens	\$255.00
Prod.#805 wd 1410 variable lens	\$280.00
Prod.#806 koyo 4000-2 var lens	\$275.00

### Circuit Cad by Softcircuit @

Prod.#840 PCLO JR	\$ 59.00
Prod.#841 PCLO	\$175.00
Prod.#842 PCLO+	\$430.00

Terms: All orders are pre-paid. Please send money orders or cashiers checks and \$5.00 for shipping and handling to Overbyte Computer Software P.O. Box 82302, Lincoln, Neb. 68501-2302 all orders are subject to price changes without notice. Not responsible for type errors. All orders are subject to availability. Nebraska residents add 5.5% sales tax. All manufacturers Warranties apply to most items.  
(402) 477-8773 call evenings 4:30 to 9:00 central time

## PERFORMANCE! OR HOW TO OUTFRAN THE 'SUN'.

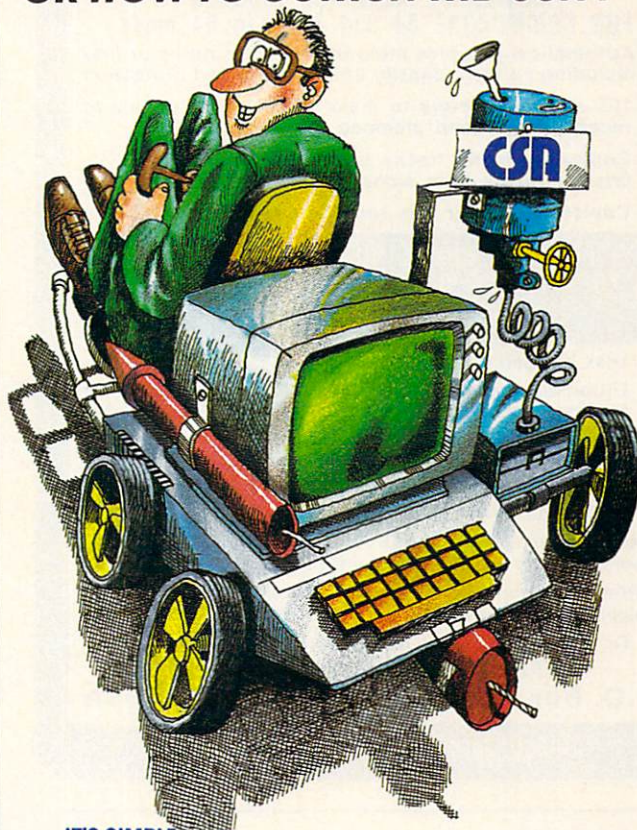

IT'S SIMPLE.

**JUST CALL THE PERFORMANCE EXPERTS AT CSA, THE AWARD WINNING, TECHNOLOGICAL LEADER OF PERFORMANCE ENHANCEMENT PRODUCTS FOR THE AMIGA!**

Now you can transform your Amiga 500, 1000, or 2000 into a super-powerful, low-cost workstation by sporting a 68020 full 32-bit processor and optional 68881 co-processor "Piggyback" or CPU board from CSA.

### CSA. YOUR PERFORMANCE BOOSTER!

Want to improve performance up to a whopping 200%?

Just run with a 14MHz 68020 alone. Now if you want to cross the finish line with up to a 400% performance increase, then add CSA's 32-bit RAM. For programs requiring a high degree of "number crunching", adding a 20MHz 68881 can reduce your running time from several days down to a matter of minutes!

### LEAVING 'EM IN THE DUST.

Independent benchmark tests indicate vastly superior performance to the Macintosh II, VAX 8800, and Sun 3/160 Workstation.

Whether you want to speed up your ray trace program from *hours* to *minutes*, or simply reduce the run time on your spreadsheet from *minutes* to *seconds*, call CSA today.

CSA.

We have the best solutions over the Sun.



**Computer System Associates, Inc.**

7564 Trade Street, San Diego, CA 92121  
(619) 566-3911 • TELEX 333-693

Macintosh is the trademark of Apple Computer Corp. VAX is the trademark of Digital Equipment Corp. Amiga is the trademark of Commodore Business Machines, Inc.



# V4.0

## ULTRABYTE DISK NIBBLER

### POWERFUL NEW GCR NIBBLER FOR COMMODORE 64 and 128 (in 64 mode)

- Automatically copies most disks in 2 minutes or less including variable density and rapid locked protection
- 105 new parameters to make unprotected copies of recent disks. Send stamped envelope for list
- Copies up to 40 tracks using 1 or 2 1541 or 1571 drives. Copies both sides on 1571
- Copies itself (for this reason, no refunds given)

**SPECIAL — BUY A NIBBLER V4.0 AND GET  
YOUR CHOICE OF A FREE \$14.95 PROGRAM**  
\$39.95 plus \$4.00 shipping

1. Disk Surgeon V2.0 -- new disk utility ..... \$14.95
2. Ultramail -- mail list and labels ..... both for  
Handy-Capper -- race handicapper ..... } \$14.95
3. McMurphy's Mansion -- text adventure ... } both for  
Solware -- solutions to 10 adventures ... } \$14.95

( Above may be ordered separately for \$14.95 plus \$4.00 shipping. Foreign orders add \$2.00 )

Mastercard, Visa, Check or M.O., Calif. add 6.5% (\$2.60) sales tax. Foreign orders / COD add \$2.00. Payment must be in U.S. funds

UPDATES - Return original Ultrabyte disk with \$15.00 plus \$4.00 shipping. Foreign add \$2.00. No free disk with update

To order, write or call 24 hr. order line. For info. write.

**ULTRABYTE (818) 796-0576**  
P.O. Box 789 LaCanada, CA 91011 USA

**DEALERS & DISTRIBUTORS WANTED**

## COMMODORE $\leftrightarrow$ IBM MS-DOS FILE TRANSFER UTILITY

### THE BIG BLUE READER 128™



If you have the Commodore 128™ and the 1571/1581 disk drive, you can read from and write to standard IBM MS-DOS files using BIG BLUE READER 128™.

#### BIG BLUE READER 128™ Features:

- File transfers between Commodore 64/128, MS-DOS and C128 CP/M diskettes.
- Full support for 1571 and 1581 disk drives (including 1581 CP/M and 3.5" MS-DOS diskettes).
- Optional ASCII to Commodore ASCII translation.
- Easy to use fully menu-driven program.

**BIG BLUE READER 128™ \$44.95**

Available at your dealer or order direct from:

#### SOGWAP Software

115 Belmont Road  
Decatur, IN 46733  
call (219) 724-3900

(Send U.S. funds drawn on U.S. Banks only).  
Price includes shipping and handling.  
**CALL OR WRITE for INFORMATION on  
C-64 LITTLE BLUE READER**

### 1541/1571 Drive Alignment

1541/1571 Drive Alignment reports the alignment condition of the disk drive as you perform adjustments. On screen help is available while the program is running. Includes features for speed adjustment and stop adjustment. Complete instruction manual on aligning both 1541 and 1571 drives. Even includes instructions on how to load alignment program when nothing else will load! Works on the C64, SX64, C128 in 64 or 128 mode, 1541, 1571 in either 1541 or 1571 mode! Autoboots to all modes. Second disk drive fully supported. Program disk, calibration disk and instruction manual only \$34.95!

### Super Disk Utilities

Super Disk Utilities is the ultimate utilities disk for the 1571 disk drive and C128 computer. Works with 1 or 2 drives. Contains disk copier, file copier, disk editor, CP/M utilities, drive monitor, numerous CBM & MS-DOS utilities and more for \$39.95!

### The Communicator

The Communicator is the fastest, easiest, most efficient, feature-packed telecommunications program available for the C64. Macro key options, X-modem protocols, 50 to 2400 baud, terminal emulation and more! Supports Commodore and Hayes compatible modems. Only \$39.95!

### Christmas Classics

One hour of Christmas music with words and graphics only \$9.95!

**Free shipping & handling!** Illinois residents add 8% sales tax. Order from:

Free Spirit Software, Inc.  
538 S. Edgewood  
La Grange, IL 60525  
(312) 352-7323



## I Saved Time and Money with Physical Exam

I use a data base to keep records for our club. Last week I experienced read errors. Luckily I have a 1541 Physical Exam program. The alignment test confirmed what I had suspected, my drive was out of alignment. I am happy to report that I aligned my drive MYSELF. I avoided the wait for repair and paid a fraction of the cost.

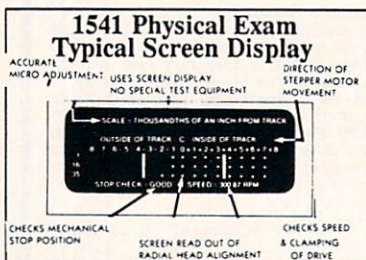

Please specify  
drive 1541,  
1571, 8050,  
8250, 4040, or  
SFD 1001

Package includes: • True digital alignment disk with offset tracks. • Mechanical Stop Test • Speed test • Illustrated manual with instructions for performing alignment, adjusting speed and stop position. • Hard copy mode to print test results for future reference.

**Physical Exam \$39.95** Plus S & H!

Cardinal Software, 14840 Build America Dr.,  
Woodbridge, VA 22191 Info: (703) 491-6494

Orders: **800 762-5645**



**TAKE COMMAND  
WITH THE NEW  
AND IMPROVED  
COMMAND CENTER**

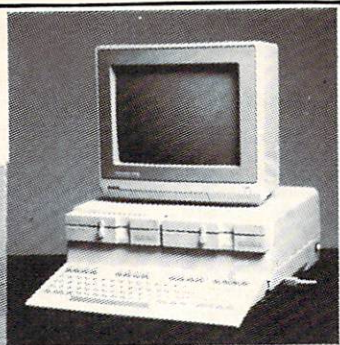

128 ... \$124.95  
64 ... 109.95  
64C ... 109.95

**-KETEK**



P.O. Box 203  
Oakdale, IA 52319

For faster service, call  
1-800-626-4582 toll free  
1-319-338-7123 (IA Residents)

Shipping and Handling

Continental U.S.  
\$4.50 for each Command Center  
\$2.00 for one accessory item  
\$3.00 for two or more accessories

APO/FPO/CANADA/PUERTO RICA  
HAWAII/ALASKA  
\$13.00 for each Command Center  
\$ 4.00 for one accessory item  
\$ 6.00 for two or more accessories

Just look at these features:  
Built-In Power Strip with surge  
and noise protection  
Built-In Cooling Fan  
Modular Phone Plug with Switch  
(optional on 64 & 64C)  
Master Power Switch  
Compatible with Single  
or Dual Drives

Accessories:  
Dust Cover - 19.95  
Keyboard Cover - 19.95  
Drive Reset - 14.95  
Tilt-Swivel Monitor Stand - 14.95  
Serial Cable - 9.95  
Cartridge Port Ext. Cable - 24.95  
Modem Switch - 9.95



**Data Director**  
**\$39.95**

Eliminates Cable Swapping  
Shares 2 6-pin Serial Devices  
LED Indicator Lights  
Reset Button

**INFO REVIEW POLICY**

Most magazines (INFO included) employ freelance writers to write reviews. But there is one big difference between us and them. At many magazines, policy allows the writer to receive product directly from the vendor, and then keep the software (as part of their compensation) after the review.

This system has a couple of drawbacks: these freelancers may be overgenerous in their reviews to insure future cooperation from manufacturers, and the magazine may not end up with the specific product reviewed- often necessary for later reference.

At INFO. Our editors request the software from the manufacturer and have it shipped to our offices. We take a preliminary look, then assign the piece to one of our regular free-lancers. When they are done with the review, it comes back to us. We keep it on file for reference and for comparison with other products.

We think our system works better. Our writers don't have a vested interest in the products they review. The software company usually has no contact with the writers, and so can't influence them. The result is unbiased reviews and better, more reliable information.

If your company is approached by writers asking for products to review for INFO, please verify their requests with us, and ship the product directly to our Iowa City offices for assignment and forwarding.

# THE SHOW Commodore

Sat. & Sun. Jan. 30-31, 1988  
San Mateo County Fairgrounds  
San Mateo, California

Sat. & Sun. Oct. 1-2, 1988  
The Disneyland Hotel  
Anaheim, California

- ★ EXHIBITS, EVENTS AND DOOR PRIZES
- ★ NATIONALLY KNOWN COMMODORE SPEAKERS
- ★ SPECIALS & DISCOUNTS
- ★ SEE THE LATEST HARDWARE AND SOFTWARE TECHNOLOGY

The Commodore Show is the only West Coast exhibition and conference which focuses exclusively on the AMIGA, Commodore 128 and 64.

COMMODORE SHOW  
**ADMISSION \$10**

**CONTACT**



**RK PRODUCTIONS, INC.**

P.O. BOX 18906, SAN JOSE, CA 95158  
(408) 978-7927 • 800-722-7927 • IN CA 800-252-7927

# Slimline '64 Case

A NEW IMAGE FOR  
THAT FAVOURITE  
COMPUTER

- Easy to Fit
- Lower key height

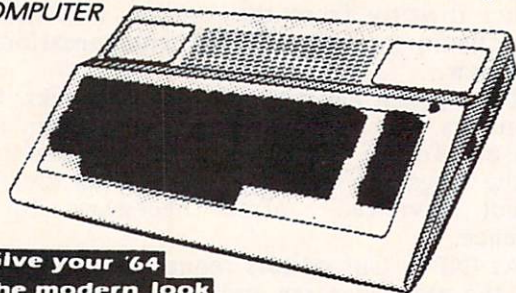

**Give your '64  
the modern look**

Now you can have that sleek new look without buying a new computer. Our replacement case will give your '64 the modern look and color you have been wanting. Installation takes just 10 minutes and requires only a Phillips screwdriver. So don't be stuck with the old look when the Slimline is here and ready for immediate shipping.

Our price of \$34.95 includes handling charges. Certified checks or postal money orders will be shipped on receipt. Personal checks must be held for 4 weeks pending bank clearance. Sorry, no OOD's. Charge cards can order by calling (902) 892-6372.

**GDP**  
Grapevine Data Products

P O BOX 1886  
Charlottetown PEI  
Canada C1A 7N5

# NEW!

## DocuMentor

Software Authors!  
Put your user manual on disk with your product! Save Printing and mailing costs!  
As simple as typing - just key it in. \*User selects what to read through menus of your design.\* User can make hard copy. Pays for itself as soon as you use it!  
Includes List Master \$44.95

## LIST MASTER

List/Outline/Idea Processor; Project Planner processes "tree" structured text. No logical limit to list size or levels of indentation. Single keystroke commands. Lines can be marked, colored & hilted. Context-sensitive help. Also useful for mailing labels, catalogs, do lists & much more! \$29.95

## MENU MASTER

Upgrades LIST MASTER to DocuMentor \$19.95

## SORT/MERGE

Quickly sort up to 8 input files. Up to 8 keys, ascending or descending, can be alpha, numeric (including exponential), signed or unsigned binary (hex) or packed decimal. Records can be BASIC, fixed, variable or delimited. Sort up to 1/3 disk using 1 drive; full disk using 2 or more. Free yourself from buffer size limitations and enhance your applications! \$19.95

## LOTTO LUCK

Lottery number chooser for any state lottery. Also 3- & 4-digit games. Purely random numbers. Get away from birthdates! Over 100 good luck messages, music & entertaining display. \$9.95

All programs: C-64, min. 1 disk reqd. Not copy-Protected.

VISA, Mastercard, Checks, Money Orders.  
CA residents add 6% (BART counties 6 1/2%) sales tax  
Add \$2.50 shipping & handling  
Allow 2-3 weeks for delivery  
Dealer Inquiries Welcome



QUALITY SOFTWARE ...

# XYTEC

1924 Divisadero/San Francisco, CA 94115 (415) 563-0660

# Quality Hardware From SCI

## The FSD-2 Excelerator + Plus

- 100% compatible for the 64 or 64C
- Faster, quieter, more reliable than the 154I or 154IC
- Breakthrough direct drive technology
- Full one year warranty
- Half height drive, smaller and slimmer than the 154I
- Separate power supply, drive remains cool
- Priced at \$159.

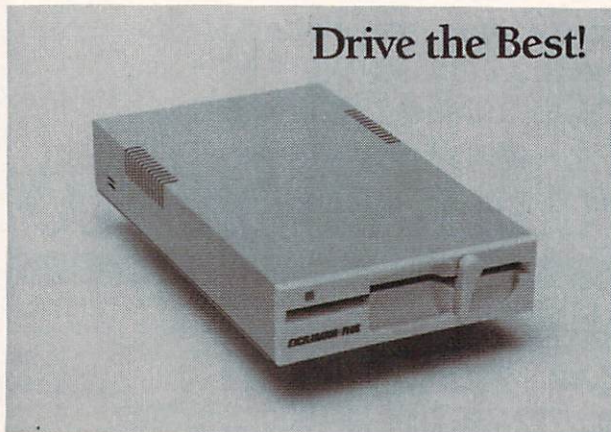

Drive the Best!

## Slimline 64

- Sleek new replacement case for the 64
- Takes only 10 minutes with a phillips to install
- Gives your 64 a new image
- Priced at \$29.



## Freeze Machine

- The ultimate archival device
- Totally unstoppable freeze utility
- Built-in file copier
- Two fast loads
- Priced at \$39.



1-800-548-9669

**SCI** Surfside Components International  
P.O. Box 1836 Capitola, CA 95010  
In California; 408-462-9494

Policy: Visa/MC/Money Order, Personal Checks (require 3 weeks to clear). California residents add 6.5% sales tax. Prices reflect 4% cash discount, add 4% for credit cards.



# Looking for a Supercartridge?? Don't finalize the deal!!

Are you thinking of buying a multi-function cartridge? Well, don't make a FINAL decision until you look at this comparison chart.

Super Snapshot 64 V2.0 has just been updated to make it an even better utility than before! We've even added features like system reset capability and a sector editor!

- Super Snapshot is upgradeable. There is no need to discard your cartridge for a new version.
- Copies most memory resident software on today's market.
- Snapshot programs run without the SS cartridge.
- Our cartridge is easily updated with up to 40K.
- Our Turbo/DOS is the most compatible fast loader tested to date.
- Attention C128 owners: An optional switch is available which allows you to disable the C64 mode with cartridge in place. \$5.00 additional.
- Super Snapshot 64 V1.0 owners may upgrade for \$20.00. Contact us for details.
- Super Snapshot 64 is for the C64 or the C128 in the 64 mode.

**Super Snapshot  
Only \$54.95**

**SOFTWARE**  
  
**SUPPORT**  
INTERNATIONAL



Super Snapshot 64 V2.0 (SS) Vs. the Final Cartridge® V2.0 (FC)*	SS	FC
Compatible with ALL C64/C128/SX64/MSD/1541/1571/& 1581 equipment?	Y	N
Is the cartridge itself designed to be easily upgradeable?	Y	N
Features both pre-programmed and user-definable function keys?	Y	N
Will it print both multi-color and standard bit mapped screen dumps?	Y	N
How many different sizes can the screen dumps be printed at?	3	1
Save graphic screens to disk in either Koala™ or Doodle™ formats?	Y	N
Menu driven with easy to read, full screen windows?	Y	N
Features both a fast loader and a fast disk formatting option?	Y	N
C-64™/1581 fast load support (20+ blocks/sec.)	Y	N
Unique "RESUME" feature (proof that SS does NOT corrupt memory)?	Y	N
Does the built-in Machine Language monitor corrupt memory (see above)?	N	Y
M/L monitor accessible from a running program with resume feature intact?	Y	N
How much ROM does the cartridge contain?	32	16
How much RAM does the cartridge contain?	8	0
Does the cartridge work with popular multi-slot expansion boards?	Y	N
Is ALL Ram and Rom accessible from the Machine Language monitor?	Y	N
Is the cartridge TOTALLY invisible to software when disabled?	Y	N
Supports C128 fast mode during screen dumps?	Y	N
Does the cartridge support multiple disk drives?	Y	N
Is the cartridge supported with a FREE Kracker Jax parameter disk?	Y	N
FREE shipping and handling on all orders within the United States?	Y	N

CHECKS, MONEY ORDERS OR VISA/MASTERCARD/DISCOVER: Mail your orders to:  
Software Support International, 2700 NE Andresen Road, D-13, Vancouver, WA 98661 • Phone orders welcome: (206) 695-1393  
Same day shipping. No C.O.D. orders outside U.S.  
PLEASE NOTE: Free shipping & handling on all orders. • C.O.D. add \$4.00 to total order. • All orders must be paid in U.S. funds.  
Washington residents add 7.30% sales tax to order. Orders outside of North America add \$7.50 for shipping.  
In Canada, order from: Marshview Software, PO Box 1212, Sackville NB E0A-3C0. Only \$69.95 CDN.

**DEALERS—WE HAVE THE SUPPORT YOU'RE LOOKING FOR!**

\*Final Cartridge is a registered trademark of H & P Computers of America. Comparison date 11-1-87.

## UNLEASH THE DATA ACQUISITION AND CONTROL POWER OF YOUR COMMODORE C64 OR C128. *We have the answers to all your control needs.*

### NEW! 80-LINE SIMPLIFIED DIGITAL I/O BOARD

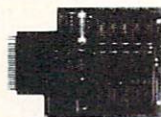

Create your own autostart dedicated controller without relying on disk drive.

- Socket for standard ROM cartridge.
- 40 separate buffered digital output lines can each directly switch 50 volts at 500 mA.
- 40 separate digital input lines. (TTL).
- I/O lines controlled through simple memory mapped ports each accessed via a single statement in Basic. No interface could be easier to use. A total of ten 8-bit ports.
- Included M.L. driver program optionally called as a subroutine for fast convenient access to individual I/O lines from Basic.
- Plugs into computer's expansion port. For both C64 & C128. I/O connections are through a pair of 50-pin professional type strip headers.
- Order Model SS100 Plus. **Only \$119!** Shipping paid USA. Includes extensive documentation and program disk. Each additional board \$109.

We take pride in our interface board documentation and software support, which is available separately for examination. Credit against first order.  
SS100 Plus, \$20. 64IF22 & ADC0816, \$30.

### OUR ORIGINAL ULTIMATE INTERFACE



- Universally applicable dual 6522 Versatile Interface Adapter (VIA) board.
- Industrial control and monitoring. Great for laboratory data acquisition and instrumentation applications.
- Intelligently control almost any device.
- Perform automated testing.
- Easy to program yet extremely powerful.
- Easily interfaced to high-performance A/D and D/A converters.
- Four 8-bit fully bidirectional I/O ports & eight handshake lines. Four 16-bit timer/counters. Full IRQ interrupt capability. Expandable to four boards.

Order Model 64IF22. \$169 postpaid USA. Includes extensive documentation and programs on disk. Each additional board \$149. Quantity pricing available. For both C64 and C128.

### A/D CONVERSION MODULE

Fast. 16-channel. 8-bit. Requires above. Leaves all VIA ports available. For both C64 and C128. Order Model 64IF/ADC0816. Only \$69.

## SERIOUS ABOUT PROGRAMMING?

**SYMBOL MASTER MULTI-PASS SYMBOLIC DISASSEMBLER.** Learn to program like the experts! Adapt existing programs to your needs! Disassembles any 6502/6510/undoc/65C02/8502 machine code program into beautiful source. Outputs source code files to disk fully compatible with your MAE, PAL, CBM, Develop-64, LADS, Merlin or Panther assembler, ready for re-assembly and editing. Includes both C64 & C128 native mode versions. 100% machine code and extremely fast. 63-page manual. The original and best is now even better with Version 2.1! Advanced and sophisticated features far too numerous to detail here. \$49.95 postpaid USA.

**C64 SOURCE CODE.** Most complete available reconstructed, extensively commented and cross-referenced assembly language source code for Basic and Kernal ROMs, all 16K. In book form, 242 pages. \$29.95 postpaid USA.

**PTD-6510 SYMBOLIC DEBUGGER for C64.** An extremely powerful tool with capabilities far beyond a machine-language monitor. 100-page manual. Essential for assembly-language programmers. \$49.95 postpaid USA.

**MAE64 version 5.0.** Fully professional 6502/65C02 macro editor/assembler. 80-page manual. \$29.95 postpaid USA.

**NEW ADDRESS!**

**SCHNEDLER SYSTEMS**  
Dept. 18 25 Eastwood Road, P.O. Box 5964  
Asheville, North Carolina 28813 Telephone (704) 274-4646

**NEW ADDRESS!**

**SOLUTIONS UNLIMITED**

**BILLBOARD MAKER \$24.95**

Blow up your Pictures up to 16x  
Doodle-Koala formats etc.  
Create Mural Size Pictures  
INFO\* \*\* \*Rating

**ICON FACTORY v2 \$24.95**

Exchange Graphics/Pictures between  
Newsroom -Print Shop Printmaster  
Doodle Koala-etc. formats.  
Enlarge/ Reduce MORE

INFO\* \*\* \*Rating

**PHOTO FINISH \$19.95**

Prints optimized pictures  
Full printer control w/Great Results  
More than a printer Utility

**SCREEN F/X \$24.95**

Create animated scripts with your  
own pictures Hi-Res/Multicolor.  
Easy to use-Professional Results

All Products above include Grafix Link  
(Geos Picture Conversion)

**AMIGA 500/2000  
CALL FOR PRICING**

Internal 31/2 drives \$130.00  
External 31/2 drives \$225.00  
1200 Baud Modem \$125.00  
Bridgecard CALL  
Hard Disk Controller (2000) CALL  
20-40 MEG HARD DRIVES  
LOW PRICES (500/1000/2000) CALL

**AMIGA SOFTWARE**

AEFIS ANIMATOR \$ 99.00  
VIDEOSCAPE 3D \$140.00  
AEGIS DRAW PLUS \$199.00  
MAXIPLAN \$110.00  
DIGI PAINT \$ 45.95  
DIGI VIEW \$145.00  
CAMERA (2 lens) \$299.00  
PROFESSIONAL PAGE \$299.00  
WORD PERFECT \$265.00

**ALL AMIGA SOFTWARE AT  
GREAT PRICES - CALL**

**IBM COMPATIBLES-COMMODORE  
64/128 - AMIGA**

\*HARDWARE \* SOFTWARE \* REPAIRS\*

**GEOS COMPANION I  
by Relevant Software**

GEOFONT EDITOR: Edit existing GEOS fonts or Create your own from 2-48 points. Create special foreign letters and characters. Ease of use. Operates from within Geos. All created fonts can be used in GeoPrint or Write.  
PATTERN EDITOR: EDIT all 32 patterns in Geos. Create your own patterns. Custom patterns can also be loaded in GeoPaint.  
GEODUMP: Prints the Current Screen in Color or Black/White (Disk Accessory).  
CHANGE PRINTER/INPUT: Allows changes to input or printer from within an application.  
GEOSLEUTH/DISK EDITOR: Dissassemble and Edit Geos Files on the disk. (sequential) CONVERT up or down versions of Workshop files (2.0 to/from 1.3). MORE.

**A HACKERS DREAM  
\$29.95**

**GEOS COMPANION II \$29.95  
by Relevant Software**

FILE COPIER: Copy single multiple files.  
ASCII CONVERSION: Convert Geos Workshop, and Geodex files to ASCII (sequential)  
CONVERT up or down versions of Workshop files (2.0 to/from 1.3). MORE.

TURBO PASCAL \$ 59.95  
Runs in C-128 CPM Mode  
Computer Eyes \$105.00

**SOFTWARE LINK  
281 Mamaroneck Ave.  
White Plains, NY 10605  
914/683-2512  
(retail outlet)**

To Order: CALL or WRITE

**SOFTWARE LINK 914/683-2512**

P.O. Box 391 White Plains, N.Y. 10602



NO EXTRA CHARGE

TERMS: Send check or money order for total purchase price, plus \$2.75 for shipping via UPS. \$4.00 for shipping non UPS. Canada \$6.00. Personal checks (Allow 10 days to clear). NY RESIDENTS ADD APPLICABLE TAXES



**TRANSFER FILES**

**TRANSFER C64/C128 files to and from your Amiga!**

Disk-2-Disk reads your PaperClip, SpeedScript and Pocket Writer documents or other files on floppy disk directly into your Amiga. Transfers all file types. Use these transferred files with your favorite Amiga programs.

- Reads/writes 1541/4040 and 1570/1571 disk formats.
- Converts Commodore/PET ASCII to Amiga ASCII and vice versa.

**TRANSFER MS-DOS and ATARI ST files  
to and from your Amiga!**

Dos-2-Dos reads Lotus 123 worksheets, wordprocessing documents or any other files on floppy disk directly into your Amiga for use with your favorite Amiga programs.

- Reads/writes both 5.25" AND 3.5" MS-DOS disks.
- Reads/writes 3.5" Atari ST diskettes (GEM format).
- Converts ASCII file line ending characters.

Disk-2-Disk requires the Amiga model 1020 5.25" disk drive. Dos-2-Dos runs on any standard Amiga. Disk-2-Disk \$49.95, Dos-2-Dos \$55.00. Add \$3.00 for shipping and handling, CA residents add 6% sales tax.



**Central Coast Software™**

268 Bowie Drive, Los Osos, CA 93402 (805) 528-4906



We sell what we know:

**Commodore!**



**The Memory Location  
Computers for  
the Home**

396 Washington Street  
(Route 16)  
Wellesley, MA 02181  
(617)-237-6846

**AMIGA 2000**

The most powerful computer on a desktop.



**GRAPHICS** 640 x 400, 4096 colors, genlock available for combining Amiga graphics with external video signals, digitizers available  
**SOUND** stereo, four voice, built-in speech synthesizer, MIDI interfaces & sound digitizers available  
**POWER** 68000 processor with sound, graphics, and video coprocessors, multitasking op sys  
**MEMORY** standard one megabyte expandable to nine megabytes: 3.5" and 5.25" floppy drives and hard disk drives available  
**COMPATIBILITY** Bridgecard for IBM PC-XT 100% compatibility, Commodore 64 emulators in stock, Ethernet compatible

We are a full-service Commodore retailer. We stock a full line of Commodore hardware, as well as all the supplies you'll need - diskettes, furniture, printers, cables, modems, ribbons, joysticks, mice, trackballs, paper, and magazines.

Ask about our specials on add-on boards and hard disk drives

**AMIGA 500**



The Ideal Home Computer  
Graphics, Sound, Speech,  
and Power!

**Only  
What  
Works!**

The Amiga 500 is NOT half a 1000!  
TWICE the memory: 512K  
TWICE the internal expansion 1Mb  
Kickstart 12 in ROM  
STANDARD serial & parallel ports  
FULLY software compatible  
with Amiga 1000 & 2000  
IMPROVED keyboard

We carry the latest software for the Amiga, Commodore 64 and 128. We have the latest information on release dates, upgrades, recalls, capabilities and limitations. We take orders by phone and will reserve a copy of unreleased software on request.

**5 Free Games!**

Buy a Commodore 64 and get over \$100 of outrageous Epyx software - Absolutely Free!  
Winter Games  
Summer Games  
Blue Jumpmen Junior  
1/2/88 Super Cycle  
Pistop II

UPS shipping available



**Satisfaction Guaranteed!**



**MAINFRAME MANIA?**  
ORDER YOUR T-SHIRT TODAY!  
**ONLY \$8.50** plus \$3.00 shipping & handling  
T-Shirts Available in Blue, Red and Gray.

**Free T-Shirt with purchase of \$50<sup>00</sup> or more!!**  
From the Weird and Unusual Cable company . . .

**REDMOND CABLE**  
Call or write today!  
REDMOND CABLE CORP.  
206-882-2009  
17371-A1 NE 67th Ct.  
Redmond, WA 98052

VISA    MasterCard

**YOU CAN HAVE IT ALL  
THE CONVENIENCE OF A CARTRIDGE!  
THE FLEXIBILITY OF A DISK!**

THE QUICK BROWN BOX stores up to 30 of your favorite programs - Basic & M/L, Games & Utilities, Word Processors & Terminals - READY TO RUN AT THE TOUCH OF A KEY - HUNDREDS OF TIMES FASTER THAN DISK - Modify the contents instantly. Replace obsolete programs, not your cartridge. Use as a permanent RAM DISK, a protected work area, an autoboot utility. C-64 or C-128 mode. Loader Utilities included. Price: 16K \$69 32K \$99 64K \$129 (Plus \$3 S/H; MA res add 5%)  
Brown Boxes, Inc, 26 Concord Road, Bedford, MA 01730 (617) 275-0090



**THE QUICK BROWN BOX  
BATTERY BACKED RAM**

**DeluxeHelp for DeluxePaintII** **RETAIL \$34.95 PLUS SHIPPING**

Call: (385) 622-8138  
(385) 622-7849  
**AMIGA LINK**  
24hr BBS

A TRULY INTERACTIVE TUTORIAL!

GET THE MOST FROM YOUR AMIGA AND DELUXEPAINT II WITH YOUR OWN TUTOR!

**\* BECOME A TRUE POWER USER \*  
USE OUR EXCLUSIVE  
DeluxeInstructor Interface**

**MOUSE TALKER®** (narrator) included  
::: basic & advanced lessons :::  
perspective ~ stencil ~ multicycle ~ etc.

**ROB VIDEO CREATIONS**  
2574 PGA BLVD. SUITE 104  
PALM BEACH GARDENS, FLORIDA 33410

AMIGA IS A TRADEMARK OF COMMODORE-AMIGA, LTD.  
DELUXEPAINT-II IS A TRADEMARK OF ELECTRONIC ARTS

**JASON—RANHEIM  
PRODUCTS OF QUALITY FOR YOUR  
COMMODORE COMPUTER**

*promenade™ C1* The Eprom programmer respected around the world for value. Programs all popular types.  
With disk software . . . . . 99.50

**CAPTURE II**  
The best utility cartridge of its kind is now even better. Make backup disks or auto-start cartridges of your memory resident software.  
Still only . . . . . 39.95

**CAPTURE UPGRADE KIT**  
Upgrade your capture to Capture II capability with new easily installed rom.  
Includes file combiner . . . . . 12.95

**CPR-3 CARTRIDGE KIT**  
For use with Capture II. 72 K Eprom cartridge with case. (Requires promenade for programming Eproms.) . . . . . 29.95

**STARTER SET**  
Includes Promenade C1, Capture II and CPR-3 kit. . . . . 149.95

**DELUXE SET**  
As above with datarase Eprom eraser and 2 CPR-3 kits . . . . . 199.95

**CCSZ CLOCK/CALENDAR**  
Cartridge provides time and date plus 8K of battery backed ram. Independent of power failures or resets.  
Many useful features . . . . . 49.95

**CARTRIDGE BOARDS AND CASES**  
PCC-2 . . . . . 4.95  
Basic 64 mode cartridge board  
PSC-2 . . . . . 5.95  
As above, socketted.  
PCC-4 . . . . . 17.95  
4 socket, bank switched  
PRB-4 . . . . . 24.95  
Ram/Eprom, battery back-up.  
CPR-B . . . . . 12.95  
Same as in CPR-3 kit. Board only.  
PCCH-2 . . . . . 2.25  
Plastic case for above.

**EPROM ERASERS**  
Datarase . . . . . 34.95  
2 at a time, hobbyist type  
PE-140 . . . . . 89.00  
7-9 Industrial quality

**SHIPPING AND HANDLING**  
USA: UPS Surface . . . . . 3.00  
UPS 2nd day air . . . . . 5.00  
Mexico, Canada air mail . . . . . 7.00  
Other foreign air mail . . . . . 13.00  
To order toll free: . . . . . 800-421-7731  
From California: . . . . . 800-421-7748  
Technical support: . . . . . 916-823-3284  
From outside USA: . . . . . 916-823-3285  
MC, VISA, AMEX Welcome

**JASON-RANHEIM  
COMPANY**  
1805 Industrial Dr.  
Auburn, California 95603

# commodore



64C. FREE SOFTWARE! **\$129<sup>95</sup>\***  
 128. .... **\$189<sup>95</sup>\***  
 128D. .... **\$429<sup>95</sup>\***  
 C64. . . . . Refurbished . . . **\$99<sup>95</sup>\***  
 \*package pricing

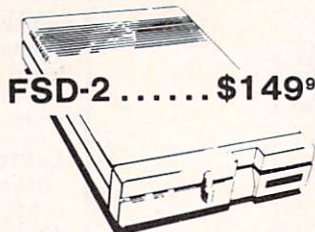

FSD-2 ..... **\$149<sup>95</sup>**

1581 ..... **\$179<sup>95</sup>**  
 1541c ..... **\$169<sup>95</sup>**  
 1571 ..... **\$219<sup>95</sup>**

MAGNAVOX 8562..... **\$240**

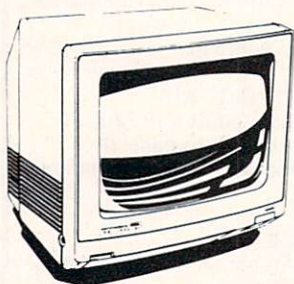

1901 (monochrome) ..... **\$99<sup>95</sup>**  
 1802c ..... **\$189<sup>95</sup>**  
 2002 ..... **\$249<sup>95</sup>**



OKIMATE 20 ... **\$99<sup>95</sup>\***  
 1351 ..... **\$34<sup>95</sup>**  
 Plug & Print ..... **\$Call**  
 Device One  
 16K Buffer ..... **\$59<sup>95</sup>**  
 1764 RAM ... **\$120<sup>00</sup>**  
 \*W/Plug & Print Purchase

## COMPLETE AMIGA LINE... \$CALL



### 500 SPECIAL PROMO

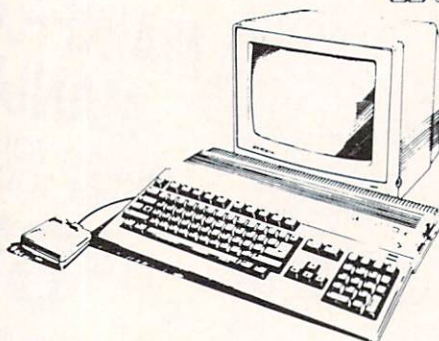

USER GROUPS  
 PACKAGE A. . . . . **\$89<sup>95</sup>**  
 PACKAGE B . . . . . **\$179<sup>95</sup>**

GENLOCK ..... **\$220<sup>00</sup>**  
 1020 Drive. . . . . **\$180<sup>00</sup>**

DIGI-VIEW ..... **\$130**

3 1/2 Drive ... **\$180<sup>00</sup>**  
 40 MEG ... **\$900<sup>00</sup>**

1680 MODEM ..... **\$120<sup>00</sup>**  
 2002. . . . . **\$Call<sup>00</sup>**

512K RAM ..... **\$120**

2 MEG. . . . . **\$349<sup>95</sup>**  
 20 MEG ... **\$649<sup>95</sup>**

Sidecar ..... **\$700<sup>00</sup>**  
 256K ..... **\$69<sup>95</sup>**

DIGI-VIEW Camera w/lens ..... **\$200**

MARAUDER II ..... **\$24**

1 MEG WITH CLOCK ..... **\$280<sup>00</sup>**

AUTHORIZED AMIGA SALES & SERVICE  
 G064 EMULATOR ..... **\$59<sup>95</sup>**

### MODEMS

PRACTICAL PERIPHERALS

5 YEAR WARR.  
 2400 ... **\$159<sup>95</sup>\***

KISS ENGINEERING

2400 INTERNAL ... **\$149<sup>95</sup>\***

Avatex

1200 Baud ... **\$79<sup>95</sup>\***  
 1200 Internal ... **\$99<sup>95</sup>\***  
 1200 H.C. .... **\$99<sup>95</sup>\***  
 2400 Baud. . . . . **\$199<sup>95</sup>\***  
 \*W/Cable Purchase

ALPS - 18 PIN 240CPS ● COLOR



**\$399<sup>95</sup>**

1 Year Warranty  
 EPSON/IBM COMP.  
 100 CPS L.Q.

FREE TRACTOR FEED

SFD 1001 FROM  
 1 MEGA BYTE **\$99<sup>95</sup>**



● IEEE CABLES ● VIC SWITCHES  
 ● IEEE INTERFACES. . . . . from 79.95  
 ● PARALLEL TO IEEE INTERFACE. . . . . \$Call

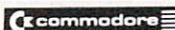

SX-64  
**\$399<sup>95</sup>**



LIMITED QUANTITY

REFURBISHED 30 DAY WARRANTY

Canon  
 COLOR INK JET  
 PJ-1080A  
**\$299<sup>95</sup>**



LIMITED QUANTITY

REFURBISHED 30 DAY WARR.

### Panasonic Industrial Company

One Panasonic Way, Secaucus, New Jersey 07094

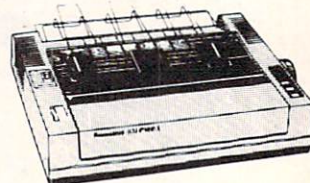

1080i-II ..... **\$160\***  
 1091i-II ..... **\$180\***  
 1092i ..... **\$280\***  
 1592i ..... **\$380\***  
 1524i ..... **\$520\***

\*W/2 Ribbon Purchase

### FREE-TRIAL OFFER!

HIGH QUALITY DS/DD DISKETTES

**19¢ each**

Lifetime Warranty  
 100% Certified W/Sleeves  
 Limit One (10) Pack Per Customer

### SEIKOSHA



● 2 Year Warr.  
 \*W/2 Ribbon Purch

SP180VC..... **\$125<sup>00</sup>\***  
 SP1000VC ..... **\$149<sup>00</sup>\***  
 SP1200AI..... **\$154<sup>00</sup>\***  
 MP1300 (300 CPS) . . . . . **\$275<sup>00</sup>\***  
 LASER ..... **\$Call**

### DISKS

3 1/2 DS/DD ..... **\$1.30**  
 3 1/2 DS/DD ..... **\$1.80**  
 SONY-FUJI-MAXWELL

5 1/4 DS/DD (100 Lot) . . . . . **25¢**  
 5 1/4 DS/DD (50 Lot) . . . . . **60¢**  
 BASF ● NASHUA

ORDERS ONLY **800-433-7756**

IN MICH. 313-427-7713

CUSTOMER SERVICE **313-427-0267** M-F 10-6

Monday thru Friday - 10:00 A.M. to 8:00 P.M.

Saturday - 10:00 A.M. to 6:00 P.M. (E.S.T.)

SCHOOL P.O.'s ACCEPTED CALL FOR TERMS

# M.C.S.

MICROCOMPUTER SERVICES

DEALER INQUIREES INVITED

No Surcharge for MC/VISA/DISCOVER  
 All returns must have RA#. Merchandise found defective will be repaired or replaced. We do not offer refunds for defective products or for products that do not perform satisfactorily. We make no guarantees for product performance. Any money back guarantee must be handled directly with the manufacturer. Call for shipping & handling info. Prices subject to change without notice.  
 12864 FARMINGTON ROAD, LIVONIA, MI 48150  
 We cannot guarantee compatibility.

**MISC**

- Most Cables.....\$15
- Casio CZ 700.....\$275
- Casio CZ 101.....\$250
- Digiview Stand.....\$50
- AB Switch.....\$30
- Mouse Pad.....\$6
- Time Saver.....\$60

**commodore**  
**Educator 64**  
**\$124.95\***

Completely Commodore Compatible  
**REFURBISHED**

FULL 90 DAY WARR.



**commodore**

**5 MEG Hard Drives 9060**

**\$299.95**  
**REFURBISHED**



**DISK ACCESS**

DISK CASE (75).....	6.95
DISK FILE (120).....	9.95
DISK NOTCHER.....	4.95
3 1/4 DATA CASE (30).....	7.95
TEAK 5 1/4 DISK HOLDER (50).....	19.95
TEAK 5 1/4 DISK HOLDER (90).....	29.95
TEAK 3 1/4 DISK HOLDER (30).....	19.95
DISK HEAD CLNR.....	8.00

**AMSTRAD**

**PC1512**

**\$599.95**



**SYSTEM INCLUDES:**

- 512K
- CGA Card
- 360K DOUBLE SIDED Drive
- 8086 (8 MHZ)
- Mouse
- Parallel & Serial Port
- Joystick Port
- Tilt Mon. Stand
- XT Style Keyboard
- Quartz Clock

**FREE SOFTWARE!**  
(500.00 Value)  
 DOS 3.2  
 GEM Desktop  
 GEM Paint  
 GEM Doodle  
 Basic 2

**PLUS:**

- Paper White Monochrome Mon. (16 Grey Levels)
- Zucker Boards... \$Call
- 1.2 MEG Drives... \$119.95
- Multi Function Cards... \$Call

**SEAGATE W/Controller**  
 20 MEG \$275\* 30 MEG \$315\*  
 \*Package Pricing

**stair**  
**MICRONICS**

**PRINTERS**

NX10.....	*\$149.95
NX10C.....	*\$159.95
NB2410.....	*\$379.95
NR15.....	*\$419.95
NX15.....	*\$279.95
Powertype....	*\$159.95

NP10 \$125.00

W/2 Ribbon Purchase



**AMIGA NEW RELEASES**

Terrorpods.....	\$ 24	Dark Castle.....	\$ 24	Deluxe Print II.....	\$ 48	Earl Weaver Baseball.....	\$Call
Test Drive.....	\$ 27	Head Coach.....	\$ 30	Word Perfect.....	\$200	Lounge Lizards.....	\$ 30
Ferrari Formula One.....	\$ 30	Gold Runner.....	\$ 24	Laser Script.....	\$ 27	Page Flipper.....	\$ 30
Fire Power.....	\$ 15	Silver.....	\$108	Empire.....	\$ 32	Videoscape 3D.....	\$120

**MOST SOFTWARE 40% OFF**

**FREE T-Shirt with the purchase of any (2) Electronic Arts Products! While Supply Lasts**

**Artic Fox** \$26.00

Bard's Tale II.....	26.00
Chessmaster 2000.....	26.00
World Tour Golf.....	20.00
Marble Madness.....	20.00
Pegasus.....	20.00
Moebius.....	26.00
Murder Party.....	23.00
Ogre.....	26.00
Ultima IV.....	38.00
Auto Duel.....	32.00
Scrabble.....	23.00
America's Cup.....	23.00
Artic Fox.....	26.00
All Classics.....	11.00
Bismark.....	26.00
Chuck Yeager.....	23.00
Tobruk.....	23.00
Paper Clip III.....	32.00
Outrageous Pages.....	32.00
Clue Books.....	\$CALL
Dan Dare.....	14.00
Earth Orbit Station.....	20.00

**Berkeley Softworks**

GEOS.....	\$36.00
Fontpak 1.....	18.00
Desk Work.....	21.00
Writer Work Shop.....	30.00
Geodex.....	24.00
GeoCalc/GeoFile.....	each 30.00
GeoCable.....	30.00
GEOS 128.....	42.00
Geopublish.....	42.00
Geoprogrammer.....	\$CALL

**Abacus**

GEOS Tricks and Tips.....	9.00
Abacus Books.....	\$\$SAVE
GEOS In and Out (Disk).....	36.00
Basic 64.....	24.00
Cadpak 128.....	36.00
Cadpak 64.....	24.00
Chartpak 128.....	24.00
Chartpak 64.....	24.00
Cobol 64.....	24.00
Cobol 128.....	36.00
Super C Compiler 64/128.....	36.00
Super Pascal.....	36.00

**SPRINGBOARD**

Certificate Maker.....	\$30.00
Newsroom.....	30.00
Clip Art 1.....	18.00
Clip Art 2.....	24.00

**MicroProse**

Gunship.....	\$21.00
F-15.....	21.00
Project Stealth Fighter.....	24.00
Airborne Ranger.....	24.00
Silent Service.....	24.00
Pirates.....	24.00
Top Gunner.....	18.00

**UNISON WORLD**

Art Gallery.....	\$16.00
Art Gallery 2.....	16.00
Print Master.....	21.00

**PRECISION**

Superbase 128.....	\$60.00
Superbase 64.....	48.00
Superscript 128.....	48.00
Superscript 128.....	48.00
Visasart 64.....	54.00
Visawrite 128.....	54.00
Microlawyr.....	36.00

**TIMEWORKS**

Data Mgr 128.....	\$36.00
Swiftcalc 128.....	36.00
Wordwriter 3.....	30.00
All business titles.....	36.00
Partner 64.....	36.00
Partner 128.....	42.00
Sylvia Porters.....	36.00
Desktop Publisher.....	\$CALL

**AT&T, Inc.**

Font Master II 64.....	\$30.00
Font Master 128.....	36.00

**SSL**

Gemstone Healer.....	\$18.00
Gettysburg.....	36.00
Kampfgruppe.....	36.00
Phantasia 2.....	24.00
Ring of Zelfin.....	24.00
Road War 2000.....	24.00
Shard of Spring.....	24.00
Wizard's Crown.....	24.00

**EDUX**

FastLoad.....	\$22.50
Rad Warrior.....	\$CALL
Street Sports.....	
-Baseball/Basketball.....	each 24.00
World Karate Champ.....	15.00
Summer Games II.....	20.00
Super Cycle.....	24.00
World Games.....	24.00
Football.....	20.00
Multi-Plan.....	24.00
Winter Games.....	20.00
Sub Battle.....	24.00
California Games.....	24.00
Boulder Dash Construction.....	\$CALL
Spy vs. Spy III.....	\$CALL

Fast Hackem..... 25.00  
 Kracker Jax..... \$\$\$Save

**MINDSCAPE**

Defender of the Crown.....	\$21.00
Bop and Wrestle.....	18.00
Super Star Hockey.....	21.00
High Roller.....	18.00
Indoor Sports.....	18.00
Infiltrator.....	18.00
Parallax.....	18.00
Uridium.....	18.00

**ACCOLADE**

Hard Ball.....	\$17.00
Apollo.....	\$CALL
Test Drive.....	\$CALL
Ace of Aces.....	18.00
Comics.....	18.00
Mini-Putt.....	18.00
Fourth and Inches.....	18.00

Jeopardy..... \$7.95  
 Wheel of Fortune..... each  
 Family Feud..... each

**ACCESS**

MACH-128.....	\$30.00
Leaderboard.....	24.00
Echelon.....	24.00
World Class Leaderboard.....	24.00
10th Frame.....	24.00
Exec Tournament.....	12.00
Tournament 1.....	12.00
Triple Pak.....	12.00
Famous Course.....	12.00

**ACTIVISION**

Portal.....	\$24.00
Titanic.....	18.00
Labrynth.....	21.00
Aliens.....	21.00
Last Ninja.....	\$CALL
Hacker II.....	21.00
Top Fuel Elim.....	\$CALL
Game Maker.....	24.00
Music Studio.....	18.00
Maniac Mansion.....	\$CALL

**HI TECH**

Card ware.....	\$ 6.00
Heart ware.....	6.00
Party ware.....	6.00
Ware with all.....	9.00

**Bruderdun Software**

Printshop.....	\$25.00
Graphics Lib.....	15.00
Carmen Sandiego.....	21.00
Karateka.....	18.00
Print shop comp.....	21.00

**SubLOGIC**

Flight Sim II.....	\$28.50
Scenery Disk.....	12.00
Jet.....	30.00
Football.....	24.00
Baseball.....	30.00

**NOVA**

Micro L. Baseball.....	\$24.00
General Mgr.....	24.00
Stat Disk.....	15.00
86' Team Disk.....	12.00

**NOVA**

Super Pack 128.....	45.00
Pocket Writer 2/Filer Planner.....	36.00
Super Pack 2 (128).....	60.00
Pocket Writer 128/Filer/Planner.....	30.00
Pocket Writer 64/Filer/Planner.....	24.00

**NEW RELEASES**

CMS Accounting.....	from 99.95
Clue Books.....	\$CALL
Star Dos.....	\$CALL
Air Rally.....	18.00
Dungeon Runners.....	18.00
Instant Music.....	18.00
Legacy of Ancient.....	18.00
Patton vs. Rommel.....	18.00
Skate or Die.....	18.00
Tomahawk.....	18.00
Monopoly.....	24.00
Mavis Beacon Typing.....	26.00
Beyond Zork.....	\$CALL
King of Chicago.....	30.00
Thunder Chopper.....	18.00
Gauntlet.....	18.00
NBA.....	\$CALL
Paper Boy.....	18.00
Nord and Bert.....	21.00
Mousetrap.....	12.00
Business Card Maker.....	\$CALL

# AMIGA<sup>®</sup> MEMORY ETC.

## MEMORY EXPANSION

*It all began 10 years ago* when Commodore introduced a wondrous PET Computer with 8 Kbytes of memory. Almost immediately Skyles Electric Works doubled the PET memory with an 8 Kbyte memory addition.

*History repeats itself 10 years later* with Skyles Electric Works offering the most complete line of AMIGA memories in the world.

Consider for the AMIGA 500:

512 Kbyte memory, with battery backup clock/calendar, plugs into bottom inside expansion connector, in 1 minute ..... \$149.95\*

1 Mbyte memory, install inside 1 hour, no soldering required ..... \$349.95\*

Consider for the AMIGA 1000:

256 Kbyte memory, plugs into the front in 5 seconds, lowest cost ..... \$79.95\*

512 Kbyte memory, no pass-thru, plugs into right side in 5 seconds ..... \$349.95\*

1 Mbyte memory, 86 pin pass-thru, connector for daughter board to expand to 2 Mbyte, plugs into right side in 5 seconds ..... \$479.95

1 Mbyte Daughter board to expand above memories, unpopulated ..... \$99.95\*

1 Mbyte Daughter board to expand above memories, populated ..... \$229.95\*

2 Mbyte memory, 86 pin pass-thru, plugs into right side in 5 seconds ..... \$649.95\*

Add \$50.00 for separate power supply for the above memories.

2 Mbyte memory, no pass-thru, plugs into right side in 5 secs ..... \$549.95\*

1 Mbyte memory, install inside, in 1 hour, no soldering required ..... \$349.95\*

Consider for the AMIGA 2000:

1 Mbyte memory, sockets to expand to 2 Mbyte, plugs into expansion connector inside, in 1 minute ..... \$399.95\*

2 Mbyte memory, plugs into expansion connector inside, in 1 minute ..... \$549.95\*

## MIDI for AMIGA

A Standard MIDI IN, 2 MIDI OUT, and MIDI THRU Interface for the AMIGA Computers. Plug it into the RS-232 Port on the rear of your AMIGA and you are ready to use Musical Instrument Digital Interface (MIDI) instruments and devices with your AMIGAs. Designed to be used with standard MIDI cables and all the presently available AMIGA MIDI software. The MIDI for AMIGA Interfaces get the job done at a bargain price. Please specify your AMIGA model number.

MIDI for AMIGA 500/1000/2000 ..... \$49.95\*

\*Due to trade games being played by U.S. and Japan all prices are subject to change without notice. There is an additional \$4.50 U.S. and Canada, \$15.00 Europe and Asia, shipping charge per order. California residents add sales tax.

TO ORDER: Call 1-800-227-9998 or 1-415-965-1735 (CA) or write to:

For More Information: Send Stamped Self Addressed Envelope to:

231-E South Whisman Road, Mountain View, CA 94041

## FREE SOFTWARE

1000 plus free programs are available to AMIGA users. Now SKYLES ELECTRIC WORKS has compiled a directory of all these free public domain programs. The directory is called P-DASE (Public Domain Amiga Software Encyclopedia). P-DASE contains a listing of all the Public Domain diskettes directories. P-DASE also lists programs by categories, Graphics, Animation, Sound, etc. P-DASE tells you where and how to obtain any or all of these free programs. P-DASE ..... \$9.95\* Please send Cash, Check, or Money Order only.

## COMING SOON

### HARD DISK DRIVE

A SCSI Standard Hard Disk Drive Interface that fits inside the AMIGA 500, 1000, and 2000. A panel mounted connector for the AMIGA 1000 and AMIGA 2000 ready to plug into your 20, 30, or 40 Megabyte Hard Disk. A 2 foot cable and connector comes with the AMIGA 500. We will be offering a complete package; SCSI Standard Hard Disk Interface, 20, 30, or 40 Megabyte Hard Disk, and an optional 1 Megabyte Memory Expansion. All at amazingly low prices. Call or Write for more details.



**Skyles  
Electric  
Works**

**New!**

## The 'Kickstart' Guide to the AMIGA<sup>™</sup>

by

ARIADNE SOFTWARE LTD

For the Commodore Amiga (tm) 500 and 1000!

This GUIDE, first published in England, includes feature articles from Ariadne Software LTD's much acclaimed Amiga(tm) journal. It explains key concepts of the machine in a way which doesn't assume you know about them already, and which is designed to compliment the official documentation as much as possible. Chapters in the book include such topics as introducing you to the 68000 processor, multi-tasking, 'C' programming, graphics, the AmigaDOS (tm) and much more. Retail price \$24.95 US (plus Shipping and Handling). And AVAILABLE NOW!

(TM) COMMODORE ELECTRONICS LTD.

ORDER LINE:

(800) 222-4441

**MicroPace**

1212 Hagan, Champaign, IL 61820  
Dealer inquiries welcome

# Amazing COMPUTING™

Your Original AMIGA™ Monthly Resource

## FEATURING

### AMIGA

- Complete Amiga Hardware and Software Reviews
- A vast and growing library of over 130 Public Domain Software Disks
- The Complete Resource for both the beginner and advanced Amiga User
- Understandable program listings and tools
- Step-by-step Hardware projects

### AMIGA

Amiga Users have made Amazing Computing™ the longest running monthly magazine dedicated to the Commodore Amiga. If you are searching for technical information that is both current and understandable, then be amazed by the pioneer Amiga magazine.

Amazing  
COMPUTING™  
Your Original AMIGA™ Monthly Resource

## Yes, Amaze Me!

I have enclosed \$24.00 U.S. (\$30.00 Canada & Mexico, \$35.00 Overseas) for a one-year subscription in check or money order (U.S. funds drawn on a U.S. Bank) to:

PiM Publications, Inc.  
P.O. Box 869-IF  
Fall River, MA 02722

NAME \_\_\_\_\_  
ADDRESS \_\_\_\_\_  
CITY \_\_\_\_\_ ST \_\_\_\_\_ ZIP \_\_\_\_\_

IN CASE YOU MISSED IT...

## THE COMMODORE & AMIGA USER'S BIBLE

OVER 2000  
PRODUCTS LISTED  
FOR C64, C128, &  
AMIGA

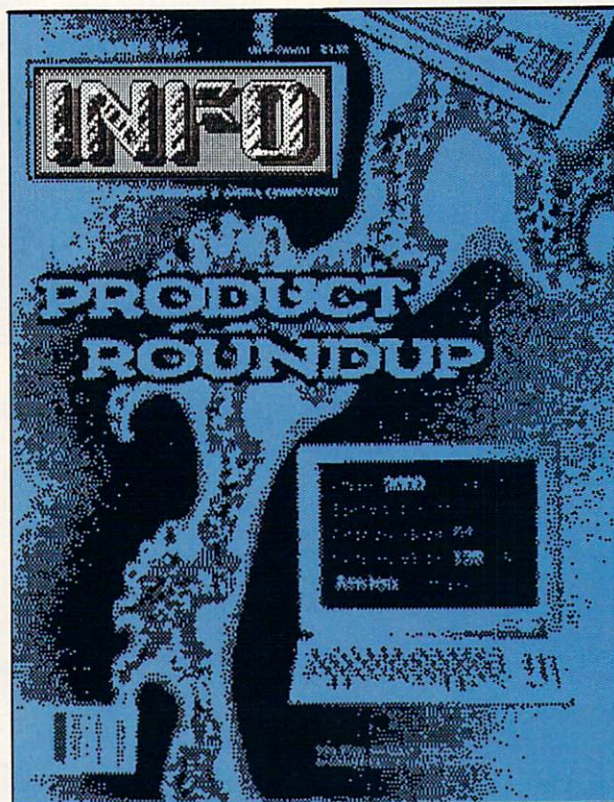

A fat  
160  
pages  
ONLY \$5.50  
(while supplies last)

Use the handy order envelope!  
Check off back issue #14.

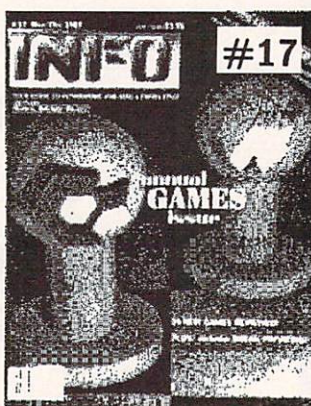
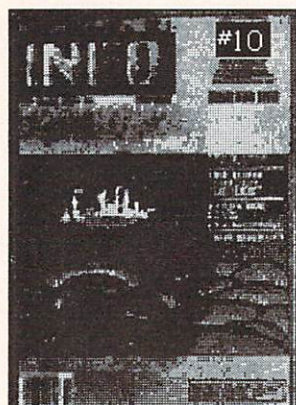
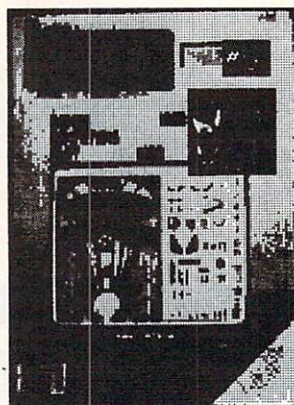
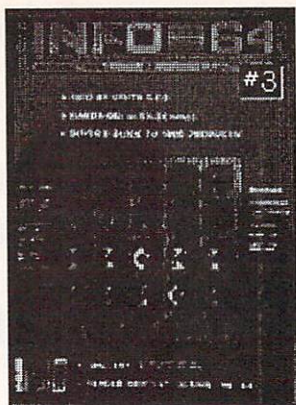

## BACK ISSUES

SEND ME ISSUES:				 <b>\$5.50</b> (U.S.) Each
1	<input type="checkbox"/>	2	<input type="checkbox"/>	
3	<input type="checkbox"/>	9	<input type="checkbox"/>	
10	<input type="checkbox"/>	11	<input type="checkbox"/>	
12	<input type="checkbox"/>	13	<input type="checkbox"/>	
14	<input type="checkbox"/>	15	<input type="checkbox"/>	
16	<input type="checkbox"/>	17	<input type="checkbox"/>	

SEND CHECK OR MONEY ORDER (U.S.)

Name: \_\_\_\_\_

Add: \_\_\_\_\_

City: \_\_\_\_\_

State: \_\_\_\_\_ Zip: \_\_\_\_\_



# DISCOVER

## THE BEST IN SOFTWARE TODAY. . .

. . . and tomorrow with the new line of products from the leader in innovative quality programming, **Discovery Software International**. From games to high powered productivity tools **DSI** is changing the way the world works and plays by unlocking the hidden potential of the **Amiga™**!

**The #1 Arcade Block-Buster!** All the action, speed and fun you've been waiting for! Dazzling graphics, digital stereo sound, and furious game play make **Arkanoid™** a breakthrough in arcade realism. Now Amiga™ is the ultimate game machine! Only **\$49.95\*** and available for **immediate shipping!**



These fully **multitasking power tools** are perfect on screen emulations of the world renowned **Hewlett-Packard™ advanced programmable calculators**. Both **DX-16C**, the ultimate programmers tool, and **DX-11C**, a multi-purpose scientific calculator, are included to make this package a double value at **\$49.95\*!**



Free yourself from constant disk swapping with **AMNIX**, a **UNIX™** style C-shell that replaces the disk-based Amiga DOS with **over 40 high-speed memory resident commands!** Extended batch files, comand line editing and history and environment variables make **AMNIX** a "must have" for Amiga™ power users! **\$49.95\***



The reviewers say it all:

" If you own an Amiga and don't have **Marauder II** from Discovery, you don't have one of the best tools an Amiga owner can have."

—INFO Magazine

The best copier at any price! Still only **\$39.95!\***



Print and save almost any screen the Amiga™ can display with **GRABBIT** a productivity power tool. **GRABBIT** captures the screen in an instant, regardless of what program is running at the time. Only **\$29.95!\***



### LIMITED TIME OFFER!

\*Order now and get **\$5.00 off each product** plus **Federal Express shipping absolutely free!**

To order call

## 1-800-34-AMIGA

or send check, money order or MasterCard or Visa numbers to:

**Discovery Software International Inc.**  
163 Conduit Street  
Annapolis, MD 21401  
(301) 268-9877



(Federal Express shipping in continental U.S. only.)  
Offer subject to change without notice.

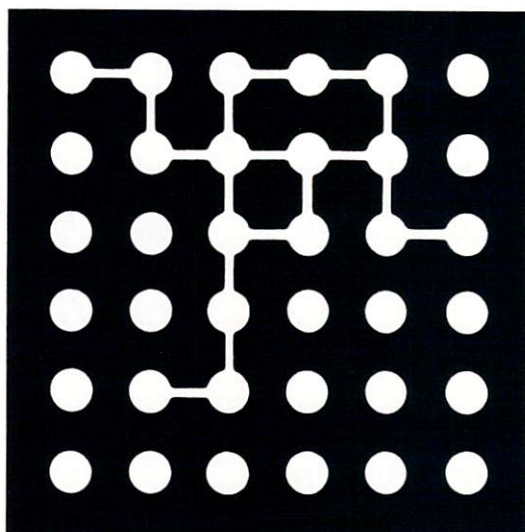

# What's a Haicalc?

*(pronounced hī-călc)*

**Haicalc™** is the best valued spreadsheet available for the Amiga. If you have ever had to project budgets, calculate expenses, or prepare a financial statement you need Haicalc. For only \$59.95 you receive a powerful program that fully utilizes the Amiga Intuition user interface.

You have the convenience of simple point & click selection of files under Workbench, pull down menu selections for commands, and economical use of your computer's memory -- program size is only 120k. You harness the power of multi-tasking and macros with

a maximum spreadsheet size of 9,000 x 9,000. Compare this to the competition. Haicalc is a powerful solution for a painless price.

## SPECIFICATIONS

Maximum Spreadsheet Size — 9,000 rows by 9,000 columns\*

Number Precision — Accurate to 8 digits

Interlace Display Ability — Up to 44 rows of data per window

Window Resolution — 1,000 by 1,000 pixels

Address Space — 18,000,000 cells\*

Program Size — 120k

Sparse Matrix Allocation — Uses memory only when a cell contains data

Copy Protection — None

System Requirements — 512k Amiga, 1.2 Kickstart, Single floppy drive

\*All capacities are subject to limits of system memory and storage.



## HAITEX RESOURCES

208 Carrollton Park

Suite 1207

Carrollton, Texas 75006

(214) 241-8030

**MONEY-BACK GUARANTEE \* TOLL-FREE 24 HOUR ORDER LINE**  
**WIDE SELECTION \* NO-NONSENSE LOW PRICES \* FREE CUSTOMER**  
**SUPPORT \* FRIENDLY & KNOWLEDGEABLE STAFF \* IMMEDIATE SHIPPING**  
**PERSONAL ATTENTION \* FOREIGN, CANADIAN, & SCHOOLS WELCOME . . .**

**NEED WE SAY MORE? LET US EARN YOUR BUSINESS!!**

**GRAPHICS & CAD**

- Anti-Glare Screens \$18
- Banner Machine (Cardinal) 30
- BASIC 8 (Patech) 39
- Billboard Maker (Sol Unlmt'd) 29
- CAD 3D (IHT) 39
- Cadpak-64 (Abacus) 29
- Cadpak-128 (Abacus) 45
- Colorez 128 (B-Ware) 12
- Cybervideo (Touchstone) 30
- Doodle (Crystal Rose) 29
- Flexidraw 5.5 (Inkwell) 29
- Lightpen 170C 75
- Lightpen 184C 49
- FlexiFont 24
- Galleries - each 21
- Holiday/Clip Art I/Clip Art II/  
Borders/Animals/Futuristic/  
Graphics Integrator 2 (Inkwell) 25
- Graphic Label Wizard (Kra Jax) 19
- Graphics Transformer (CDA) 25
- Home Designer 128 (Kendall) 45
- Icon Factory (Solo Unlmt'd) 29
- Moving Pictures (CDA) 20
- Perspectives II (Kira) 39
- Picasso's Revenge (Progress) 49
- Photo Finish (Sol Unlmt'd) 25
- Printmaster Plus (Unison) 25
- Art Gallery I or II 17
- SCREEN F/X (Solo Unlmt'd) 29

**AIDS/UTILITIES**

- Antibump Boards (CDA) 39
- 1541/1571 Dr Align (Free Sp) 20
- Assembler/Monitor (Abacus) 29
- Basic 8 (Putech) 30
- BASIC Compiler 128 (Abacus) 45
- BASIC Compiler 64 (Abacus) 29
- BBS Construction Set (Kira) 43
- Big Blue Reader (Sogwap) 25
- Big Blue Reader CP/M 32
- Bobstern Pro 64 (Progress) 39
- Bobstern Pro 128 (Progress) 49
- COBOL 64 (Abacus) 29
- Communicator 64 (FR SPRT) 20
- Gnome Kit 64/128 (Kira) 39
- Gnome Speed 128 (Kira) 29
- Hot Shot Interface (Ommit) 49
- How To Get Most GEOS Book 13
- Kyan Pascal 64 or 128 52
- Merlin 64 (Roger Wagner) 39
- Merlin 128 (Roger Wagner) 49
- Phy Exam 1541 or 1571 (Card) 29
- Power Assembler 64/128 (Spinn) 30
- Power C 64/128 (Spinn) 30
- Programmer's Tool Box (Spinn) \$17
- Prototerm 128 (B-Ware) 12
- Super C 128 or 64 (Abacus) 45

- Super Graphix (Xetec) \$69
- Super Pascal 128 or 64 (Abac) 45
- Super Snapshot (K Jax) 49
- Super 81 Utilities (Free Sp) 29
- SYSRES Enhanced (Comp Mart) 32
- Troubleshoot & Repair C64 Book 16
- Turbo Load & Save Cart (Spinn) 19
- CPM Kit 128 (Inca) 25
- TSOS Super Assembler 39

**HOME/BUSINESS**

- Accountant 128 (KFS) 119
- Add-on modules 55
- BEST A/P or A/R 45
- BEST G/L or Inventory 45
- BEST Project Planner 50
- Business Form Shop (Spinn) 30
- Checkbook 128 (Nu Age) 17
- CMS Accounting 128 129
- Inventory Module 53
- Easy Working Filer/Planner  
or Writer (Spinn) 10
- Fleet System 2+ (Professional) 39
- Fleet System 4 (Professional) 55
- FlexFile 64 or 128 (Cardinal) 39
- Fontmaster 128 (Xetec) 39
- Fontmaster II 64 (Xetec) 35
- GEOS 128 (Berkeley) 49
- GEOS 64 (Berkeley) 39
- Geoprint or Geodex 29
- Geocalc or Geofile 35
- Fontpak I or Despkak 1  
Writer's Workshop 22
- GEO Publish (Berkely) 33
- Microlawyer (Progress) 45
- Search for Stolen Sentence 12
- J K Lasser Money Manager 69
- Pocket Superpak 64 (Dig Sol) 49
- Pocket Superpak 2 64/128 69
- Pocket Dictionary (Dig Sol) 10
- Pocket Writer 64 (Dig Sol) 29
- Pocket Writer 2 (Dig Sol) 45
- Superbase 64 (Progress) 49
- Superbase 128 (Progress) 55
- Superscript 128 (Progress) 49
- ThoughtForm 64 (Gallery) 25

**PERSONAL**

- Bridgemaster (Radarsoft) 12
- Cardio Exercise (Bodylog) 69
- Celebrity Cookbook (Merrill) 25
- Classical Music (Strider) 9
- Crossword (Radarsoft) 12
- Dream Analyzer (Merrill) 25
- Enhanced Stress (Bodylog) 199
- Family Tree 128 or 64 (Geneal) 39

- Heartlab (Bodylog) \$49
- Holiday Ornament Factory 20
- Muscle Development (Bodylog) 54
- Petigree (Geneal) 59
- Sexual Edge (Merrill) 20
- Standard Stress (Bodylog) 89

**EDUCATIONAL**

- Fisher Price
- Peter Rabbit Reading (3-6) 19
- Peter & Wolf Music (3-7) 19
- Jungle Book Reading (6-9) 19
- First Men on Moon Math (9+) 19
- Widham Classics Graphic Adven
- Alice in Wonderland (10+) 9
- Treasure Island (10+) 9
- Wizard of Oz (10+) 9
- Swiss Family Robinson (10+) 9
- Below the Root (10+) 9
- Hayden Score Imp For SAT  
Math/Verbal and Exams (All) 35
- Spinnaker
- Facemaker (3-8) 22
- Alphabet Zoo (3-7) 18
- Kids on Keys (4-9) 18
- Math Busters (8-14) 22
- Kidwriter (6-10) 22
- Homework Helper Math (10+) 29
- Homework Helper Write (10+) 29
- Early Learning Friends (3-8) 6
- Grandma's House 6
- Educational Videos-Spinnaker
- Readers of Lost Alpha (5-8) 12
- Adventures of Time Taxi (5-8) 12
- Search for Stolen Sentence 12

- Talking Coloring Book (JMH) \$24
- Superbase (Progress) 69
- TV Text (Brown W) 99
- Videoscape (Aegis) 119
- Wordperfect 229
- Draw Plus (Aegis) 169
- Digi! (Aegis) 59
- Viziwrite (Progress) 99
- Amiga 500-512 Exp Boards 139
- Unicorn Educationals call

**BRIWALL**

Solid Products • Solid Support

P.O. Box 129/56 Noble St.  
Kutztown, PA 19530

**TOLL-FREE 24 HOURS**  
**1-800-638-5757**  
 (ORDERS ONLY PLEASE)

**OUR PROMISE**

**WE GUARANTEE YOUR SATISFACTION!!**

If, for any reason, you are not satisfied with your selection within 15 days of your receipt, simply return the product to us for a friendly refund of your purchase price. No hassles! You pay ONLY \$1.00 per returned item for handling. Defective items are replaced free of charge!

**!! FREE !!**

Free Spirit's  
Christmas Classics  
with any order  
over \$100.00

GOOD UNTIL 1/30/88

**\* PRODUCT OF THE MONTH!!**

**MOVING PICTURES**

**LIFE DOESN'T STAND STILL**

**WHY SHOULD YOUR PICTURES**

**FULL SCREEN ANIMATION ON YOUR C64**

**LIST \$30 OURS \$20 SPECIAL \$17\***

MOVING PICTURES is more than just another animation package! Use your favorite graphics program, such as Doodle! or Flexidraw, to draw the frames of your movie. Then use Moving Pictures, to compile these frames into a smooth animated movie, that is totally under your control. Since Moving Pictures stores only the difference between each frame, and not the entire frame, your compiled movies will be quite compact. This allows you to create much larger animated sequences and/or to store several movies in memory at the same time.

**Just a few of its features are:**

Allows split-screen operation, part graphics, part text . . . even while your movie is running.

Repeat, stop at any frame, change position and/or colors, vary display speed.

Hold several movies in memory and switch instantly from one movie to another.

Write movie scripts in BASIC, using the powerful, English-like command set for complete control of your creations.

Whether you are a programmer or a novice, you'll be able to create spectacular animated stories, movies, presentations or whatever. You can even edit your scripts or execute a BASIC program while your movie is being displayed. MOVING PICTURES is an excellent program, and at this price it is an excellent bargain!

**\* OFFER GOOD UNTIL 1/15/88**

**\* COMBINATION SPECIALS \***  
**CALL FOR LATEST SPECIALS AND PRODUCTS**

- Photo Finish + Icon Factory + Billboard Maker - \$69
- Syntech BBS + Games Module - \$59
- Flexidraw 5.5 + 170C Pen - \$100
- Flexidraw 5.5 + 184C Pen - \$75
- KFS Accountant 128 + Add-on Module - \$169
- Galleries with Flexidraw and Pen - \$19 each
- Basic 8 + Colorez 128 - \$39
- Maps Europe + USA + World - \$50
- All 5 Widham Classics - \$39
- Kids on Keys + Early Learning Friends + Grandma's House - \$28
- Easy Working Planner + Filer + Writer - \$26
- Any 3 Fisher Price Educationals - \$52
- Viziwrite 128 + Vizistar 128 - \$125
- 3 or more Classical Music Disks - \$7 each
- CP/M Kit + Big Blue Reader CP/M - \$52
- Homework Helper Math + Writer - \$49

ORDERING INSTRUCTIONS: VISA, MasterCard, Personal Check, Money Order or COD are welcome. Shipping USA: \$3.00/ground, \$5.00/2nd Day, \$14.00/overnight. C.O.D. add \$2.00. Canada/Mexico: \$6.00 Air Mail. Foreign: \$12.00 (for Air Mail use charge & specify maximum). PA residents add 6% sales tax. Include phone number and computer/drive model with order. All items will be shipped immediately, (if we are out-of-stock, we will let you know.) Charge is per order.

For CUSTOMER SERVICE please call us:  
Monday thru Friday, 9:30 a.m. - 4 p.m. EST  
1 - (215) - 683 - 5699

Call or write for our FREE CATALOG, describing in detail, hundreds of fine products for your Commodore

# WE JUST FRONT PAGE

## SNOOPS & SCOOPS

### STOCKS PLUMMET IN RECORD TRADING

In today's market, it is not unusual for the Dow Jones Industrial Average to drop more than 100 points in a single day. In fact, it has happened several times in the past few years. The market is currently in a state of flux, and investors are being advised to stay on their toes.



All these things are good news for the investor who is looking for a way to make money. The market is currently in a state of flux, and investors are being advised to stay on their toes.

### Television Highlights

**Transfer:** (1) **6:30 LAWRENCE WELK IN BULGARIA**  
The famed band leader takes you through 60 minutes of musical merriment, all the time wondering why he is in Bulgaria.

**Wednesday:** (1) **6:30 I Love Lucy**  
Lucy and Ethel hatch a plot to get Lucy into Ricky's show at the club. (R)

### Weather

**Local weather:** Look for clouds throughout the morning, turning off near midday. Temperatures should soar to the mid 200's by late afternoon with heavy electrical activity and thunderstorms appearing around, oh, say 10:00. In the evening we'll see, we can make a forecast.

**National weather:** Who cares? We don't live there. We live here. Here, the really good news is that we are not in a bad way. In fact, we are in a good way. (Continued Page 2)

# VANISHING TIMES

A Berkeley Softworks Publication Vol. XLIV Number 4567

## EARTH TO BEGIN SPINNING IN OPPOSITE DIRECTION



A shocked consortium of scientists confirmed the world's worst suspicions Tuesday, when they announced that the Earth was indeed slowing down. They expect the planet to grind to a halt early Thursday, reversing its direction and getting back up to speed by Monday night.

Although the research was startling, the scientists urged people not to panic. "I suppose I'd lock all the breakables in your cabinets," offers Dr. Lee Llevano, "but outside of that, I'd just tell people to hold on and enjoy the ride!"

Apparently we're in for quite a ride. Dr. Dennis Rowland demonstrated the effect of the sudden

reversal by dropping a raw egg into a MixMaster blender set on "puree!" "If we assume people have the consistency of this egg," Rowland asserted, "I think it's safe to say that the effect of this phenomenon will leave them in a state somewhat similar to finely ground beef."

Asked if there were anything the public could do to prepare for the

**"I'd just tell people to hold on and enjoy the ride!"**

catastrophe, Dr. Rowland thought a while and offered, "I always recommend fastening your seat belt. It just makes so much sense, don't you think?"

Analyst Staci Glovsky was less distressed with the news, asking "What's the big deal? Jeez, you guys are acting like a bunch of

inches. Anderson was booked on felony charges of dog munching, poodle endangerment and assaulting a canine with intent to commit relish. He was later released on his own recognizance. The man who offered him the poodle has also been charged with attempting to apply mustard to a mutt, a misdemeanor in Alameda County.

"It's a smear tactic," yelled Rob Siegel, the man still being sought by police. "Sure it was my mustard, but that doesn't prove a thing. Besides, they have to prove with

Continued Page 4

### Television Highlights

This week, you can expect to find some of the best programs right on your own TV set at home. Following are some of the highlights:

- Monday:** (4) **6:30 I LOVE LUCY**  
Lucy and Ethel hatch a plot to get Lucy into Ricky's show at the club. (R)
- (7) **6:30 WILD KINGDOM**  
Markon sits in a studio safe and sounds, while Jim risks his life for some unimportant animal.
- Tuesday:** (2) **7:30 LAWRENCE WELK IN BULGARIA**  
The famed band leader takes you through 60 minutes of musical merriment, all the time wondering why he is in Bulgaria.
- (5) **9:30 BRUCE LEE IN REVUE OF THE MEATBALL**  
Epic hero Bruce Lee punches his way through pasta, and rescues a pizza from 600 Neopolitan Ninjas.
- Wednesday:** (1) **6:30 I Love Lucy**  
Lucy and Ethel hatch a plot to get Lucy into Ricky's show at the club. (R)
- (4) **8:30 Gilligan's Island**  
Gilligan and the Skipper finally wise up and figure out that Ginger and Mary Anne must be getting awfully lonely right about now, and go for (Continued Page 4)

### Weather

**Local weather:** Look for clouds throughout the morning, burning off near midday. Temperatures should soar to the mid 200's by late afternoon with heavy electrical activity and thunderstorms appearing around, oh, say 10:00. In the evening we'll see, we can make a forecast. (Continued Page 2)

# ED'S WEEKLY

December 3  
Basking In The Beauty of Anderson

Headed deep in the Peninsula, between the hills of San Francisco and San Jose, the city of Anderson, California, is a beautiful town. The buildings are made of stone and brick, and the streets are paved with cobblestones. The town is a beautiful sight, and it is a pleasure to visit.

The town is a beautiful sight, and it is a pleasure to visit. The buildings are made of stone and brick, and the streets are paved with cobblestones. The town is a beautiful sight, and it is a pleasure to visit.

Continued Page 17

Continued Page 2

## More people reading stuff like this!

A poll conducted by Berkeley Softworks was released today, indicating that people actually do read the stuff that we write in these articles. The findings are about to make people. To submit, do not write me anything at all. "We know! Right! Our people read the stuff!" said Joe Gilligan in a phone interview. "Or, at least, they think they do. Or, at least, they think they do. Or, at least, they think they do. Or, at least, they think they do." (Continued Page 1)

## MAN BITES POODLE!



**BERKELEY** — Dozens of citizens watched in horror today as a man, who described himself as an animal lover, actually bit a miniature teacup poodle.

Donald Anderson, of Studio City, California, dismissed the incident as a case of mistaken identity.

"Somebody asked me if I wanted a dog with mustard, and since it was close to lunchtime anyway, I just took a bite without looking."

The dog, responding to the name "Knockwurst," then gave out a yelp that bystanders recalled as sounding like "a cross between a gun shot and

**"Sure it was my mustard, but that doesn't prove a thing!"**

an air raid siren." In the process, the pinched pooch set a world record in the long jump of thirty feet, two

# I MADE GE NEWS.

These days, the biggest story in the news is geoPublish. The page-making program for GEOS-equipped 64's and 128's that replaces lifeless layouts with page after page of powerful, punchy professionalism.

## Freedom of the press.

Actually, geoPublish is very patriotic software. After all, what other application guarantees your freedom of self-expression? Well, geoPublish sure does. In fact, every piece it prints is dedicated to the preservation of your personality on paper.

Which means that finally, your newsletters never need to look like anyone else's, ever again.

All you do is draw a bunch of columns for your master

layout. They could be two, four or sixteen across the page. They could be short and squat, or long and skinny. It's your call. After that, you just

"pour" your geoWrite document, text, graphics and all—into column after column. Page after page.

Everything fills up automatically until it fits firmly into your

finely fashioned format.

## Extras! Extras! Read all about 'em!

As every editor knows, even the best stories need punching up before they go to press. Which is why geoPublish features an array of artistic appliances designed to earn your pages a place in the history books.

You can resize text. Change fonts. Even insert or delete graphics anywhere on the page. You can lay text over graphics. Graphics over text. Or even wrap text *around* graphics.

And if your image doesn't fit, no problem. The proportional scaling tool can shrink or

enlarge any art, be it your original or the stuff you find in Print Shop.™

Finally, those of you intent on making banner headlines should know that

geoPublish doesn't wimp out

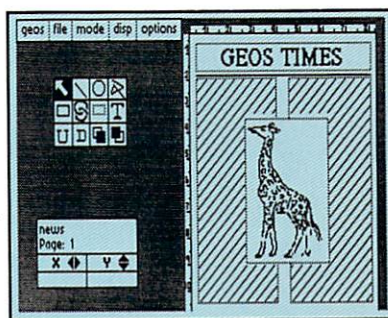

when it comes to headlines. It screams them out, with genuine, newspaper-sized, 96 point megafonts.

Now, if you think that sounds terrific on paper,

just wait until you see it printed out on a Laser-Writer.™

## We've saved the best news for last.

And now, for the best part: you can create and save not one, but hundreds of layouts for later use.

And because it's part of the GEOS family, you can fully integrate text and graphics from all your other programs into every geoPublish piece you print.

So now that you know the latest scoop in software, why not subscribe to geoPublish yourself? Who knows? With stuff like this, you could be making front page news in no time.

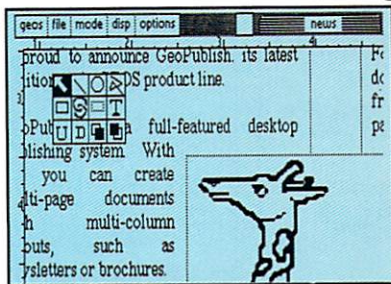

To order call 1-800-443-0100 ext. 234

**geoPublish \$69.95**

(California residents add 7% sales tax.)

\$2.50 US/\$5.50 Foreign for shipping and handling. Allow six weeks for delivery.

Commodore and Commodore C64 are trademarks of Commodore Electronics, Ltd. GEOS, geoPublish and Berkeley Softworks are trademarks of Berkeley Softworks.



**Berkeley  
Softworks**

The brightest minds are working at Berkeley.

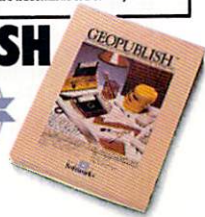

# INFO UNCLASSIFIEDS

## ADVERTISER INDEX

### INFO UNCLASSIFIEDS

\$2/Word. Send with check or M.O.  
to:

INFO UNCLASSIFIEDS  
123 N. Linn St.-Ste. 2A  
Iowa city, IA 52240

Ads received with payment by  
December 30, 1987 will appear in  
Issue #19 (on sale Feb. 16).

**AMIGA MUSIC** program users. Over  
750 studio quality sounds on diskette to  
help you make the most of your music  
program. Call **DATASOUND** at  
1-800-341-1950 ext. 24 for catalog.

**COLORFUL VIDEO** title maker for  
Commodore 64 Printshop (tm) users.  
\$14.95. MicroAds, 145 Norman Drive,  
Palatine, IL 60067

**AMIGA NUDES** Collection. Art disks  
of beautiful digitized female nudes. Volumes  
1-5. \$9.95 Each. Gallery P.D. Software, PO  
Box 2560, Athens, GA 30612-0650

**COMMODORE REPAIR.** Low prices  
(eg. C64-\$39.95 complete). We are the  
largest Authorized Service Center in the  
country. Kasara Micro Inc., 37 Murray Hill  
Drive, Spring Valley, NY 10977,  
1-800-248-2983, 800-642-7634 (outside  
NY) or 914-356-3131

**FRUGALWARE.** Inexpensive PD  
Software for Commodore 64/128 and  
Amiga. Sample disk + list \$3. **SPECIAL:** 10  
Amiga or 20 C64/128 disks -\$25 Postpaid.  
Frugalware, 23 East Green, West Hazelton,  
PA 18201

**C128 USERS** Large selection of software  
for the C128/CPM. 80cols/Business,  
Terminals, Games, Utilities. Send \$2.50 for  
C128/SAMPLER disk. CPM/STARTER  
SET (2 disks, menu driven with HELP files)  
\$5.00. Cabral's, 4 Terry Ln., Wareham, MA  
02571

**TALKING SOFTWARE** for your  
Commodore! Speaking Operating System  
Utilities. Uses BASIC "SAY" command and  
SPEECH 64 (or compatible) in Expansion  
Port. Only \$17 (includes Shipping and  
Handling). Send to: Don Hunt, PO Box  
3283, El Segundo, CA 90245

**PLUS/4, VIC 20, C64/128**  
Software, books, hardware, catalog, \$2.  
McWare, IP4, POB 2784, Fairfax, VA  
22031

**COMMODORE CHIPS.** Low prices  
two/more: 6510/6526-\$8.95, 901 series  
\$10.95, PLA/82S100-\$10.95, 6581-\$10.95  
and many others. Send for catalog. Kasara  
Micro Inc., 37 Murray Hill Drive, Spring  
Valley, NY 10977, 1-800-642-7634,  
800-248-2983 (outside NY) or  
914-356-3131

**ABNER'S BIBLE TALES**  
(Commodore 64/128 disk) 3 amusing  
respectful games. Joystick required. 100%  
ML arcade action. Send \$19.95 to: Trinity  
Software, Box 17087, Dept. F, Colorado  
Springs, CO 80935

**1670 STAND-ALONE** Interface. Run  
the 1670 on the Amiga or any PC. \$44.95,  
shipping included. COD available. For info  
write or call LRA Enterprises, 35615 Ave.  
D, Yucaipa, CA 92399. 714/797-6867

**C64 SOFTWARE.** New, used, PD and  
adult software for the C64. Send \$2.25 for  
C64/Demo disk. Cabral's, 4 Terry Ln.,  
Wareham, MA 02571

### THE LEADER IN THE FAMILY & HOME OFFICE COMPUTER INDUSTRY

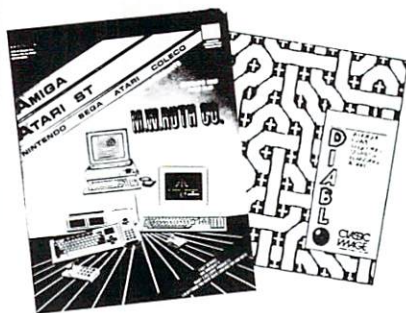

**Diablo 64 \$19.95**  
**Diablo Amiga\* \$29.95**

\*INFO rated 4+ stars issue 13

A Challenging & Addictive Fast-action  
Arcade Style Game.

M.W. Ruth Co. Dept "18"  
3100 West Chapel Ave  
Cherry Hill, NJ 08002  
(609) 667-2526

Shipping and handling \$2.50 U.S.,  
\$4.50 Canadian

SEND FOR FREE CATALOG!  
MANY EXCLUSIVE PRODUCTS  
(computer greeting cards, special  
labels, Amiga Software)

- 12 Ballistic Software
- 100 Berkeley Softworks
- 101 Berkeley Softworks
- 99 Briwall Software
- 91 Brown Boxes
- 86 Cardinal
- 90 Central Coast Software
- 85 CSA
- 97 Discovery Software
- 85 Eagle Tree
- 86 Free Spirit
- 13 Gold Disk
- 88 Grapevine
- 98 Haitex
- 95 INFO Product Roundup
- 96 INFO Back Issues
- 91 Jason Ranheim
- 87 Ketek
- 3 Loadstar
- 102 M.W. Ruth
- 92 MCS
- 93 MCS
- 90 Memory Location
- 14 Micro R&D
- C4 Microillusions
- 94 Micropace
- 14 Midwest Software
- C2 NewTek
- 85 Overbyte
- 14 P.A.V.Y.
- 95 PIM Publications
- 15 Protecto
- 9 Quantum Computer Services
- 91 Redmond Cable
- 91 RGB Video
- 87 RK Productions
- 89 Schnedler Systems
- 88 SCI
- 94 Skyles Electric Works
- 90 Software Link
- 89 Software Support Int'l.
- 86 SOGWAP
- C3 Sunrise Industries
- 20 Supra
- 4 Three Sixty Software
- 86 Ultrabyte
- 14 Xetec
- 88 Xytec

# INFO

# 1988 READER SURVEY

As you all know, magazines make you fill out reader surveys so they can "determine how to better serve the needs of our readers". Sure, you bet. Truth is, the advertisers want to know all this stuff. So we'd certainly appreciate it if you could send back a completed survey. Thanks.

## INFO & OTHER MAGAZINES

I've been reading INFO since issue # \_\_\_\_\_

Do you subscribe to INFO?  Yes  No

How many other people read your copy of INFO? \_\_\_\_\_

How would you rate INFO on a scale of 1 to 10?

(bad) 1 2 3 4 5 6 7 8 9 10 (perfect)

Are you more likely to buy a product:

- (a) directly from an ad, or  
 (b) from manufacturer's mailed literature

Which other computer magazines do you read regularly (3 out of 4 issues)?

- Ahoy!  Compute!'s Gazette  
 Transactor  Amiga World  
 Compute!  Commodore Magazine  
 RUN  Amazing Computing

## YOUR COMPUTER

I now own:

C64  C128  C128D  A500  A1000  A2000

In the next year, I plan to buy:

C64  C128  C128D  A500  A1000  A2000

I now own:  Disk Drive  Modem

Printer  Monitor  Expansion Hardware

In the next year, I plan to buy:  Disk Drive  Modem

Printer  Monitor  Expansion Hardware

How many people in your family use your computer? \_\_\_\_\_

What three things do you usually use your computer for? (Number 1 to 3)

\_\_\_ Business \_\_\_ Programming \_\_\_ Productivity  
\_\_\_ Games \_\_\_ Education \_\_\_ Graphics \_\_\_ Utilities  
\_\_\_ Wordprocessing \_\_\_ Telecommunications \_\_\_ Music

## YOUR MONEY

I spent \$ \_\_\_\_\_ on computer products in the last year.

I plan to spend \$ \_\_\_\_\_ on computer products next year.

Where do you buy most of your computer products?

- Mail Order  Computer Store  
 Discount Store  Manufacturer

## YOU

Name \_\_\_\_\_

Address \_\_\_\_\_

City \_\_\_\_\_ State \_\_\_\_\_ ZIP \_\_\_\_\_

Age \_\_\_\_\_ M/F \_\_\_\_\_ Annual Income: \$ \_\_\_\_\_

Years of schooling: \_\_\_\_\_ Profession: \_\_\_\_\_

What percentage of the people you know make and/or use "pirate" copies of commercial software? \_\_\_\_\_

## Comments:

REMOVE ALONG THIS LINE

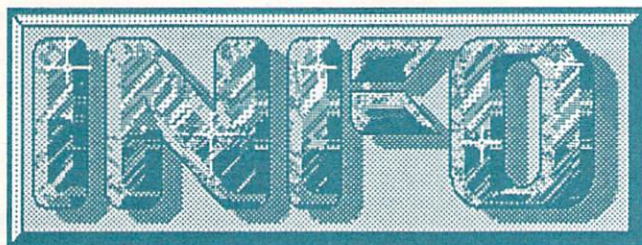

**P.O. Box 2300**  
**Iowa City, IA 52244**

FOLD HERE

STAPLE OR TAPE HERE





# **SPECIAL OFFER!**

**While Supplies Last!**

**OFFICIAL  
POCKET PROTECTOR  
(Not Available in stores!)**



# **FREE!**

**with your paid  
subscription  
(or renewal) to  
INFO Magazine.**

Pease allow 2 to 4 weeks for delivery.

**PLEASE  
FIND THE  
OTHER  
END OF  
THIS  
CARD,  
FILL IT  
OUT AND  
SEND IT  
IN.**

**Erg-boards  
& Card-sets**

TOTAL A  
FROM  
OTHER  
SIDE

**Back Issues**

TOTAL B  
FROM  
OTHER  
SIDE

**Subscription**

FROM  
OTHER  
SIDE

**GRAND TOTAL**

\$

MAKE CHECKS PAYABLE TO:  
INFO PUBLICATIONS

ENCLOSE CHECK OR MONEY  
ORDER ONLY IN U.S. FUNDS.

**SEND ALL  
THIS STUFF  
A.S.A.P. to:**

Name \_\_\_\_\_

Address \_\_\_\_\_

City \_\_\_\_\_

State \_\_\_\_\_

Zip \_\_\_\_\_

(NOTE: Items may be shipped separately.  
Allow 2-3 weeks for Erg-boards, Cards, and Back issues.)

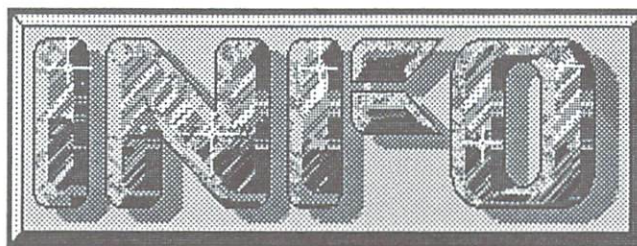

**P.O. Box 2300  
Iowa City, IA 52244**

# ERG-BOARDS & CARD-SETS

\_\_\_\_ ERG-BOARDS @ \$17.95 \_\_\_\_\_  
\_\_\_\_ CARD-SETS (#1) @ \$ 5.95 \_\_\_\_\_  
\_\_\_\_ CARD-SETS (#2) @ \$ 5.95 \_\_\_\_\_  
TOTAL A



BACK ISSUES

\$5.50 (U.S.) EACH

TOTAL B

SEND ME ISSUES:

1  6  10  13  16

2  11  14  17

3  9  12  15  18

YOU BET I WANT A SUBSCRIPTION TO



(& don't forget my keen pocket protector!)

SIGN ME UP TODAY FOR:

- 6 ISSUES **\$19.75** YOU SAVE \$3.95  
 12 ISSUES **\$37.00** YOU SAVE \$18.48  
 18 ISSUES **\$54.75** YOU SAVE \$17.10

BRAND NEW       RENEWAL

All subscriptions begin with the issue following the one on sale at the time we receive your order.

↑ DETACH ALONG DOTTED LINE ORDER TODAY AND MAIL AWAY! ↑

# Real time video and music.

SunRize introduces **PERFECT VISION** and **STUDIO MAGIC** to enhance the look and the sound of your Amiga.

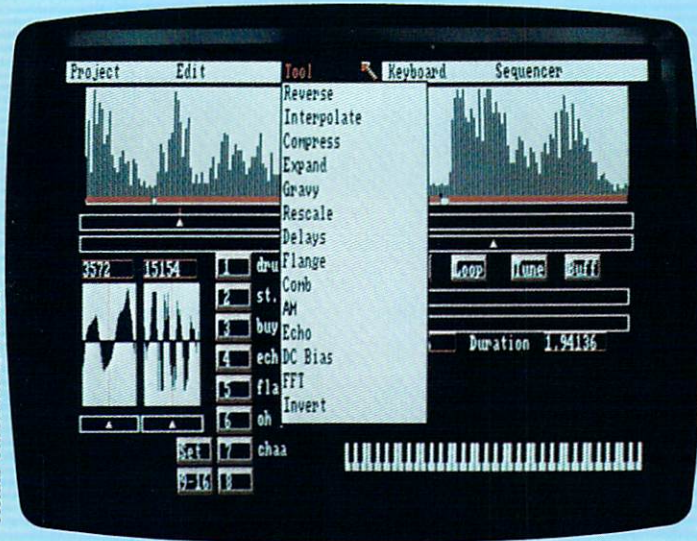

**STUDIO MAGIC** is the ultimate music and sound workshop with features superior to editors selling for thousands more. Compatible with model 1000, 500 and 2000 Amigas. Input sounds from stereo, VCR or microphone (with **PERFECT SOUND** interface) or a keyboard (with MIDI interface).

Create flanges, delays, echoes, compression and expansion to speed up (or slow down) without pitch change, do backward masking, etc. Other features include comb filter, DC bias, AM, Fast Fourier Transforms and visual representation of the sounds in the buffer.

A dozen menu driven tools allow you to make a child's voice sound like a titan or turn a TV pitchman into an alien from another galaxy. Record MIDI input in real time. Mix voices and instruments and control their playback using a MIDI keyboard. Overdub from 16 digitized "sections" and play back four of them at a time. Supports advanced MIDI features such as tempo adjust and external sync. Store sounds in IFF "instrument" or "one-shot" (8SVX) files for use with other compatible programs.

**SUGGESTED RETAIL PRICE: \$99.95**

**PERFECT VISION** is the state of the art, real time video digitizer for use with model 1000, 500 and 2000 Amigas. Input from a color (or black and white) video camera or a VCR. Perfect Vision will digitize the image, display it in 4096 colors (camera input only), then store it as IFF for later use in compatible programs. Captures an image in 1/60 of a second — 600 times faster than the competition. Supports 320x200 and 320x400 HAM and 16-color modes.

**SUGGESTED RETAIL PRICE: \$219.95**

Available from Amiga dealers across America. For product information and support call:

 **SunRize Industries**  
3801 Old College Road  
Bryan, TX 77801  
(409) 846-1311.

AMIGA is the registered trademark of Commodore—Amiga, Inc. Studio Magic and Perfect Vision are registered trademarks of SunRize Industries.

# HAPPY HOLIDAYS FROM MICROILLUSIONS



## THIS SEASON MICROILLUSIONS' OFFERS:

For Amiga, C64/128 and MS DOS:

FAERY TALE ADVENTURE Today's hottest game! / BLACKJACK ACADEMY / ROMANTIC ENCOUNTERS AT THE DOME.

For Amiga and soon for C64/128 and MS DOS:

LAND OF LEGENDS / PLANETARIUM / EBONSTAR / FIREPOWER / GALACTIC INVASION / TURBO.

For Amiga:

DISCOVERY and DISCOVERY EXPANSION DISKS / PHOTON VIDEO / DYNAMIC CAD / MUSIC X / DYNAMIC WORD.

**microillusions**<sup>TM</sup>

17408 Chatsworth Sr., Granada Hills, CA 91344 • Inside CA 818/360-3715 • Outside CA 800/522-2041 • FAX 818/360-1464